

Functionalization of the C-4 position of 1-methylpyrazole

Author: BenchChem Technical Support Team. **Date:** May 2026

Compound of Interest

Compound Name: *3-(1-methyl-1H-pyrazol-4-yl)butanoic acid*

CAS No.: 1540383-56-9

Cat. No.: B2980916

[Get Quote](#)

Application Note: Strategic Functionalization of the C-4 Position of 1-Methylpyrazole

Executive Summary

The 1-methylpyrazole scaffold is a privileged structure in medicinal chemistry, serving as a core pharmacophore in numerous kinase inhibitors (e.g., Crizotinib), COX-2 inhibitors (e.g., Celecoxib), and agrochemicals. While the N1-methyl group blocks the nitrogen, the carbon skeleton offers three potential sites for functionalization: C3, C4, and C5.

This guide focuses exclusively on the C-4 position. This position is electronically distinct as the "beta" carbon of the enamine-like system, making it the primary vector for Electrophilic Aromatic Substitution (EAS). Conversely, it is the least acidic position, rendering it difficult to access via direct lithiation without blocking groups. This note details two high-fidelity workflows to access C-4 diversity:

- Classical Route: Regioselective Halogenation followed by Cross-Coupling.
- Advanced Route: Sterically-Controlled Iridium-Catalyzed C-H Borylation.

Reactivity Profile & Mechanistic Logic

To successfully functionalize C-4, one must understand the competing electronic and steric forces within the ring.

- **Electronic Control (EAS):** The lone pair on the graph-pyrrolic nitrogen (N1) donates electron density into the ring. Resonance structures show that this density is delocalized primarily to C-4. Therefore, electrophiles () preferentially attack C-4.^[1]
- **Acid/Base Control (Lithiation):** The proton at C-5 is the most acidic () due to the inductive electron-withdrawing effect of the adjacent N1. Treatment with strong bases (e.g., -BuLi) results in exclusive C-5 lithiation. Do not use direct lithiation to target C-4.
- **Steric Control (Ir-Catalysis):** Bulky transition metal catalysts (e.g., Ir-dtbpy systems) avoid the substituents at N1 and the lone pair at N2, favoring the sterically accessible C-4 position.

Visualizing the Reactivity Landscape

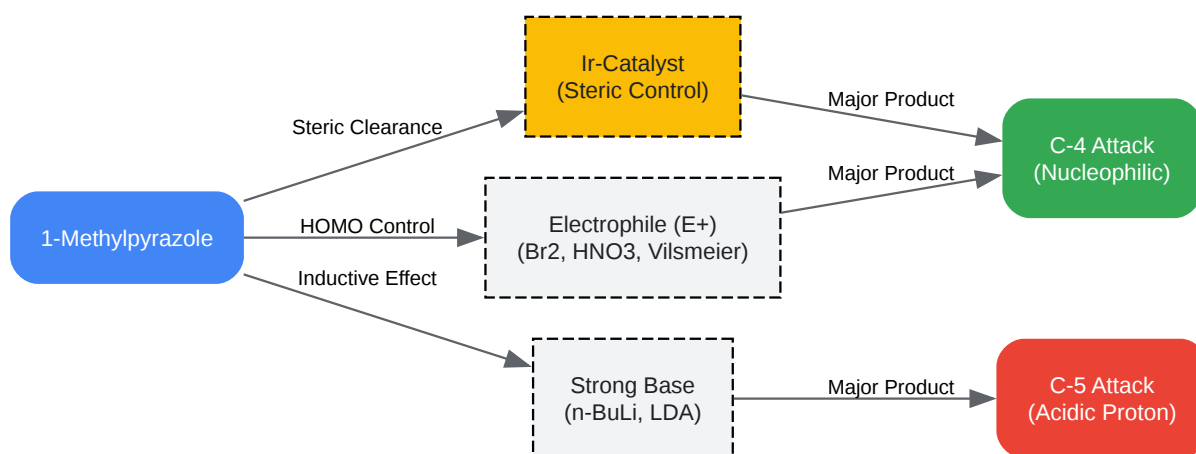

[Click to download full resolution via product page](#)

Figure 1: Divergent reactivity modes of 1-methylpyrazole. Electrophiles and bulky catalysts target C-4, while strong bases target C-5.

Protocol A: The Classical Route (Halogenation & Coupling)

This is the industry-standard method for generating C-4 libraries. It relies on the high nucleophilicity of C-4 to install a halogen handle (Br or I), which is subsequently engaged in Suzuki-Miyaura coupling.

Step 1: Regioselective C-4 Bromination

Objective: Synthesize 4-bromo-1-methyl-1H-pyrazole with >95% regioselectivity.

Materials:

- 1-Methylpyrazole (1.0 equiv)
- N-Bromosuccinimide (NBS) (1.05 equiv)
- Acetonitrile (MeCN) or DMF (0.5 M concentration)
- Saturated NaHCO₃ solution, Brine, Ethyl Acetate.

Procedure:

- **Dissolution:** Charge a round-bottom flask with 1-methylpyrazole and MeCN. Cool to 0°C in an ice bath. Note: MeCN is preferred over DMF for easier workup, though DMF accelerates the reaction.
- **Addition:** Add NBS portion-wise over 15 minutes. The exotherm is mild, but rapid addition can lead to poly-bromination.
- **Reaction:** Allow the mixture to warm to room temperature (RT) and stir for 2–4 hours.
 - **Checkpoint:** Monitor by TLC (Hexane/EtOAc 3:1) or LCMS.^[2] The product is less polar than the starting material.
- **Workup:** Concentrate the solvent in vacuo. Redissolve the residue in Ethyl Acetate. Wash with sat. NaHCO₃ (2x) to remove succinimide byproducts, followed by brine.

- Purification: Dry over Na_2SO_4 and concentrate. The crude material is typically >95% pure. If necessary, purify via silica flash chromatography (0-20% EtOAc in Hexane).

Step 2: Suzuki-Miyaura Cross-Coupling

Objective: Couple the C-4 bromide with an aryl boronic acid.^{[2][3]}

Materials:

- 4-Bromo-1-methylpyrazole (1.0 equiv)
- Aryl Boronic Acid () (1.2 equiv)^[2]
- Catalyst: (3-5 mol%)
- Base: (2.0 M aqueous solution, 3.0 equiv)^[2]
- Solvent: 1,4-Dioxane (degassed)^[2]

Procedure:

- Setup: In a microwave vial or pressure tube, combine the bromide, boronic acid, and Pd catalyst.
- Inertion: Seal the vessel and purge with Nitrogen/Argon for 5 minutes.
- Solvent Addition: Add degassed Dioxane and aqueous via syringe.
- Reaction: Heat to 90°C for 4–12 hours (or 110°C for 30 min in a microwave reactor).
 - Mechanism:^{[4][5][6][7][8][9][10]} The electron-rich pyrazole ring can sometimes poison Pd catalysts.

is robust; however, if conversion is low, switch to

- Isolation: Filter through a Celite pad, dilute with EtOAc, wash with water, and purify via column chromatography.

Protocol B: The Advanced Route (Ir-Catalyzed C-H Borylation)

This route circumvents the halogenation step, directly installing a boronic ester at C-4. This is ideal for late-stage functionalization or when the "halogen-dance" side reaction is a concern.

Scientific Rationale: Iridium catalysts ligated by bipyridines (e.g., dtbpy) are sensitive to steric bulk. In 1-methylpyrazole, the C-5 position is sterically crowded by the N-methyl group relative to the bulky active catalyst species. Consequently, the catalyst activates the C-H bond at C-4.

Materials:

- 1-Methylpyrazole (1.0 equiv)
- Bis(pinacolato)diboron () (0.55 equiv - Note: 1 mole of provides 2 boron atoms, but often 1.0 equiv is used to drive kinetics)
- Pre-catalyst: (1.5 mol%)
- Ligand: 4,4'-di-tert-butyl-2,2'-bipyridine (dtbpy) (3.0 mol%)
- Solvent: Hexane or THF (anhydrous)

Procedure:

- Glovebox/Schlenk Technique: This reaction is oxygen-sensitive.

- **Catalyst Formation:** In a vial, mix $\text{IrCl}_3 \cdot x\text{H}_2\text{O}$, dtbpy, and a small portion of $\text{B}(\text{pinac})_3$ in solvent. The solution should turn dark brown/red, indicating formation of the active tris(boryl)iridium species.
- **Substrate Addition:** Add the 1-methylpyrazole and the remaining $\text{B}(\text{pinac})_3$.
- **Reaction:** Heat at 60–80°C for 4–8 hours.
 - **Self-Validating Step:** Monitor by GC-MS.[2] The appearance of the M+126 peak (mass of pinacol ester minus H) confirms borylation.
- **Workup:** Evaporate volatiles. The resulting crude pinacol boronate is often stable enough for direct use in a subsequent Suzuki coupling (One-Pot Protocol) without isolation.

Comparative Data & Troubleshooting

Feature	Protocol A (Halogenation)	Protocol B (C-H Borylation)
Regioselectivity	High (>98% C-4). Driven by electronics.	Good (~90% C-4). Driven by sterics.[11] Minor C-3 isomers possible.
Scalability	Excellent (Multi-gram to kg).	Moderate (Cost of Ir catalyst is high).
Atom Economy	Lower (requires Br/I waste).	High (Direct H replacement).
Common Failure	Poly-halogenation: If NBS is in large excess.	Protodeboration: C-4 boronates can hydrolyze on silica.

Expert Insight - Troubleshooting:

- **Issue:** Protodeboration during purification of the C-4 boronate.

- Solution: Do not purify the boronate on silica gel. Filter the crude reaction mixture through a short plug of Celite and take it directly into the Suzuki coupling step (One-Pot).
- Issue: Low yield in Suzuki Coupling due to Pd poisoning.
 - Solution: Pyrazoles are good ligands for Pd. Increase catalyst loading to 5 mol% or use a precatalyst like XPhos Pd G3, which is resistant to coordination by the substrate.

References

- Reactivity of Pyrazoles (General Theory)
 - Joule, J. A.; Mills, K. *Heterocyclic Chemistry*, 5th Ed.; Wiley: Chichester, 2010.
 - Source:
- Regioselective Halogenation of Pyrazoles
 - Elguero, J. et al. "Pyrazoles." *Comprehensive Heterocyclic Chemistry II*.
 - Source:
- Iridium-Catalyzed Borylation (Steric Control)
 - Hartwig, J. F. et al. "Iridium-Catalyzed C-H Borylation of Heteroarenes: Scope, Regioselectivity, and Application to Late-Stage Functionalization." *Chemical Reviews*, 2010, 110(2), 890–931.
 - Source:
- Suzuki Coupling Protocols for Heterocycles
 - BenchChem Technical Support.[1][2] "Application Notes and Protocols for Suzuki Coupling Reactions."
 - Source:
- Direct Arylation Nuances (Pd vs Ir)
 - Fagnou, K. et al.

- Source:

Need Custom Synthesis?

BenchChem offers custom synthesis for rare earth carbides and specific isotopic labeling.

Email: info@benchchem.com or [Request Quote Online](#).

Sources

- [1. pdf.benchchem.com](https://pdf.benchchem.com) [pdf.benchchem.com]
- [2. pdf.benchchem.com](https://pdf.benchchem.com) [pdf.benchchem.com]
- [3. researchgate.net](https://researchgate.net) [researchgate.net]
- [4. The General Mechanism for Electrophilic Aromatic Substitution Reactions | MCC Organic Chemistry](#) [courses.lumenlearning.com]
- [5. \(PDF\) The Suzuki-Miyaura Cross-Coupling Reaction of Halogenated Aminopyrazoles: Method Development, Scope, and Mechanism of Dehalogenation Side Reaction](#) [academia.edu]
- [6. chem.libretexts.org](https://chem.libretexts.org) [chem.libretexts.org]
- [7. Electrophilic aromatic substitution - Wikipedia](https://en.wikipedia.org) [en.wikipedia.org]
- [8. researchgate.net](https://researchgate.net) [researchgate.net]
- [9. ccc.chem.pitt.edu](https://ccc.chem.pitt.edu) [ccc.chem.pitt.edu]
- [10. quora.com](https://quora.com) [quora.com]
- [11. Iridium-Catalysed C–H Borylation of Heteroarenes: Balancing Steric and Electronic Regiocontrol - PMC](#) [pmc.ncbi.nlm.nih.gov]
- To cite this document: BenchChem. [Functionalization of the C-4 position of 1-methylpyrazole]. BenchChem, [2026]. [Online PDF]. Available at: [https://www.benchchem.com/product/b2980916/docs#functionalization-of-the-c-4-position-of-1-methylpyrazole]

Disclaimer & Data Validity:

The information provided in this document is for Research Use Only (RUO) and is strictly not intended for diagnostic or therapeutic procedures. While BenchChem strives to provide

accurate protocols, we make no warranties, express or implied, regarding the fitness of this product for every specific experimental setup.

Technical Support: The protocols provided are for reference purposes. Unsure if this reagent suits your experiment?

Need Industrial/Bulk Grade? [Request Custom Synthesis Quote](#)

BenchChem

Our mission is to be the trusted global source of essential and advanced chemicals, empowering scientists and researchers to drive progress in science and industry.

Contact

Address: 3281 E Guasti Rd

Ontario, CA 91761, United States

Phone: (601) 213-4426

Email: info@benchchem.com

[Contact our Ph.D. Support Team for a compatibility check](#)