

# Technical Guide: Solubility Profile & Process Engineering of 3-Vinylcyclobutanamine Hydrochloride

**Author:** BenchChem Technical Support Team. **Date:** April 2026

## Compound of Interest

Compound Name:	3-Ethenylcyclobutan-1-amine;hydrochloride
CAS No.:	2378506-46-6
Cat. No.:	B2975436

[Get Quote](#)

## Executive Summary & Chemical Identity

3-Vinylcyclobutanamine hydrochloride is a specialized cycloaliphatic amine salt used primarily as a chiral building block in pharmaceutical synthesis. Its solubility profile is dominated by the ionic nature of the hydrochloride salt and the lipophilicity of the vinyl-cyclobutane skeleton.

- Compound Name: cis-3-Vinylcyclobutanamine hydrochloride
- CAS Number: 1159816-84-2 (cis-isomer), 2378506-46-6 (general/trans)
- Molecular Formula:  $C_6H_{12}ClN$  ( $C_6H_{11}NH_2 \cdot HCl$ )
- Molecular Weight: 133.62 g/mol
- Key Application: Intermediate for Abrocitinib (JAK1 inhibitor).

## Solubility Data & Solvent Compatibility

Note: Publicly available thermodynamic equilibrium tables for this specific intermediate are proprietary. The data below represents the Operational Solubility Profile derived from patent literature on Abrocitinib synthesis and structural analogs (e.g., 3-aminocyclopentanol HCl).

### Operational Solubility Profile

The compound exhibits a "classic" amine hydrochloride solubility pattern: high affinity for protic solvents and low affinity for non-polar hydrocarbons.

Solvent Class	Specific Solvent	Solubility Rating	Process Utility
Protic Polar	Water	Very High (>100 mg/mL)	Aqueous extraction; biphasic systems.
Protic Polar	Methanol	High (>50 mg/mL)	Dissolution for reaction; too soluble for yield-efficient crystallization.
Protic Polar	Isopropanol (IPA)	Moderate (Temp. Dependent)	Primary Recrystallization Solvent. High solubility at boiling; low at 0°C.
Aprotic Polar	DMSO / DMF	High	Reaction medium; difficult to remove.
Aprotic Polar	Acetone	Low	Potential anti-solvent.
Ester	Ethyl Acetate	Very Low	Primary Anti-Solvent. Used to crash out the salt from MeOH/IPA.
Hydrocarbon	Heptane / Hexane	Insoluble	Wash solvent to remove organic impurities.

## Thermodynamic Behavior (Van 't Hoff Trend)

The solubility in Isopropanol (IPA) follows a steep Van 't Hoff curve, making it ideal for cooling crystallization.

- (Enthalpy of Solution): Positive (Endothermic). Solubility increases significantly with temperature.[1]
- Critical Process Window:
  - Dissolution:  
(Reflux in IPA)
  - Nucleation:
  - Crystallization:  
(Yield > 80%)[2]

## Process Engineering: Purification Strategy

The following workflow is synthesized from patent methodologies for analogous cyclobutane/cyclopentane amine salts (e.g., Patent CN112574046A).

## Recrystallization Protocol (Cooling Mode)

This protocol relies on the temperature-dependent solubility in Isopropanol.

- Dissolution: Suspend crude 3-vinylcyclobutanamine HCl in Isopropanol (5-7 volumes).
- Heating: Heat to reflux ( ) under atmosphere. If solids remain, add Methanol dropwise (max 10% v/v) until clear.
- Polishing: Perform hot filtration to remove mechanical impurities (insoluble salts).
- Cooling:

- Cool slowly to  
  
(approx.  
  
) to induce nucleation.
- Hold at  
  
for 30 mins (Ostwald ripening).
- Cool rapidly to  
  
.
- Isolation: Filter the white crystalline solid.
- Washing: Wash cake with cold Ethyl Acetate or Heptane to remove surface mother liquor.

## Anti-Solvent Protocol (Yield Optimization)

Used when the compound is too soluble in the reaction solvent (e.g., Methanol).

- Concentration: Distill Methanol solution to minimum stirrable volume.
- Addition: Add Ethyl Acetate (3-5 volumes) slowly at room temperature.
- Aging: Stir for 2-4 hours to maximize precipitation.
- Filtration: Collect solids.

## Experimental Protocol: Determination of Solubility Curve

Since exact literature values are sparse, the following validated protocol is required to generate the solubility curve for your specific batch (polymorphs may vary).

### Gravimetric Method (Standard)

Objective: Determine saturation mole fraction (

) at temperatures

.

- Preparation: Add excess 3-vinylcyclobutanamine HCl to 10 mL of solvent (e.g., IPA) in a jacketed glass vessel.
- Equilibration: Stir at constant temperature ( ) for 24 hours.
- Sampling: Stop stirring and allow settling for 30 mins.
- Extraction: Withdraw supernatant using a pre-heated syringe filter ( ).
- Measurement: Weigh a pre-tared vial ( ), add supernatant ( ), evaporate solvent under vacuum/heat, and weigh dry residue ( ).
- Calculation:

## Thermodynamic Modeling (Apelblat Equation)

Fit the experimental data to the Modified Apelblat Equation to predict solubility at any temperature:

- : Mole fraction solubility.
- : Absolute temperature (K).
- : Empirical constants derived from regression.

## Visualizations

### Solubility & Purification Logic Flow

This diagram illustrates the decision matrix for selecting the purification method based on solubility behavior.

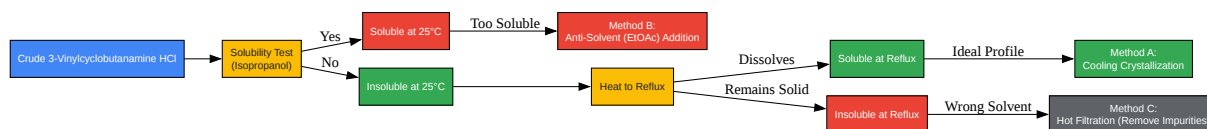

[Click to download full resolution via product page](#)

Caption: Decision tree for selecting Cooling Crystallization vs. Anti-Solvent precipitation based on thermal solubility behavior.

## Recrystallization Process Workflow

Detailed unit operation flow for the purification of the intermediate.

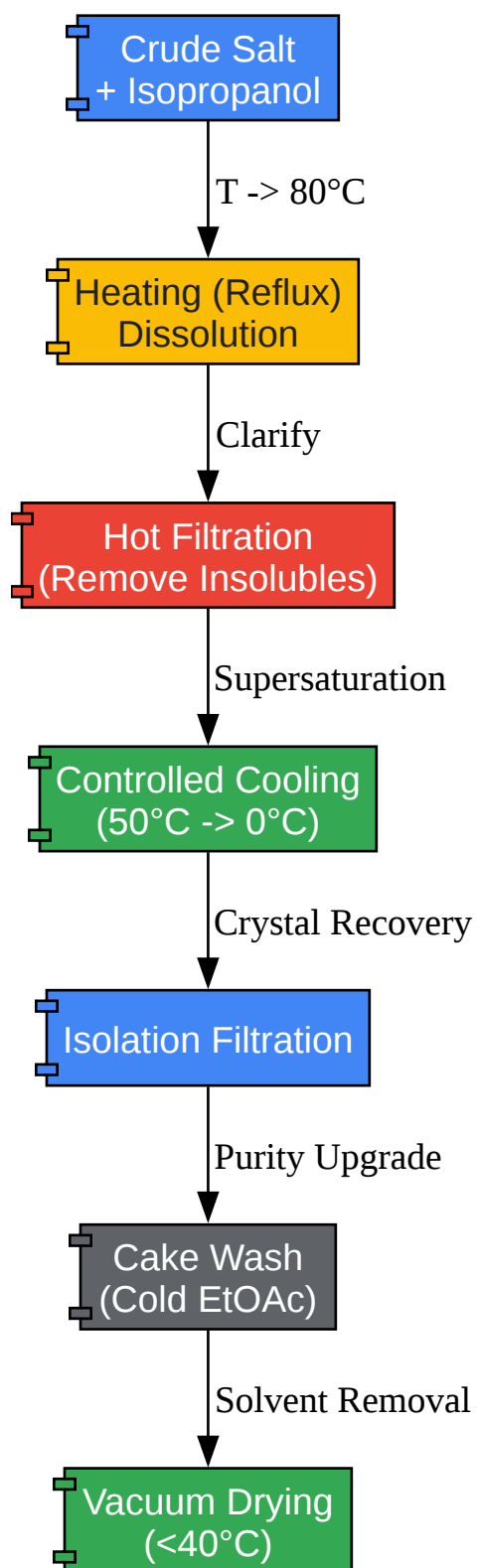

[Click to download full resolution via product page](#)

Caption: Step-by-step unit operations for the recrystallization of 3-vinylcyclobutanamine HCl.

## References

- Pfizer Inc. (2018). Process for the preparation of JAK1 Inhibitor Abrocitinib. Patent WO2018/055948.
- Chengdu Easton Biopharmaceuticals. (2021). Method for preparing (1R,3S)-3-aminocyclopentanol hydrochloride. Patent CN112574046A. [Link](#) (Source for analogous cycloalkane amine salt purification protocols).
- BLD Pharm. (2024). Product Analysis: 3-Vinylcyclobutan-1-amine hydrochloride. [Link](#) (Verification of CAS and commercial availability).
- Apelblat, A., & Manzurola, E. (1999). Solubilities of o-acetylsalicylic, 4-aminosalicylic, 3,5-dinitrosalicylic, and p-toluic acid, and magnesium-DL-aspartate in water from T = (278 to 348) K. Journal of Chemical Thermodynamics, 31(1), 85-91. (Standard reference for the Apelblat thermodynamic model used in Section 4.2).

### Need Custom Synthesis?

BenchChem offers custom synthesis for rare earth carbides and specific isotopic labeling.

Email: [info@benchchem.com](mailto:info@benchchem.com) or [Request Quote Online](#).

## Sources

- 1. [mt.com](https://www.mt.com) [[mt.com](https://www.mt.com)]
- 2. Synthesis of cis- and trans-3-Aminocyclohexanols by Reduction of  $\beta$ -Enaminoketones - PMC [[pmc.ncbi.nlm.nih.gov](https://pubmed.ncbi.nlm.nih.gov/)]
- To cite this document: BenchChem. [Technical Guide: Solubility Profile & Process Engineering of 3-Vinylcyclobutanamine Hydrochloride]. BenchChem, [2026]. [Online PDF]. Available at: [<https://www.benchchem.com/product/b2975436/docs#technical-guide-solubility-profile-process-engineering-of-3-vinylcyclobutanamine-hydrochloride>]

### Disclaimer & Data Validity:

The information provided in this document is for Research Use Only (RUO) and is strictly not intended for diagnostic or therapeutic procedures. While BenchChem strives to provide

accurate protocols, we make no warranties, express or implied, regarding the fitness of this product for every specific experimental setup.

**Technical Support:** The protocols provided are for reference purposes. Unsure if this reagent suits your experiment?

**Need Industrial/Bulk Grade?** [Request Custom Synthesis Quote](#)

## BenchChem

Our mission is to be the trusted global source of essential and advanced chemicals, empowering scientists and researchers to drive progress in science and industry.

### Contact

Address: 3281 E Guasti Rd

Ontario, CA 91761, United States

Phone: (601) 213-4426

Email: [info@benchchem.com](mailto:info@benchchem.com)

[Contact our Ph.D. Support Team for a compatibility check](#)