

A Comparative Analysis of Aminopyridine Isomers' Biological Activity: A Guide for Researchers

Author: BenchChem Technical Support Team. **Date:** April 2026

Compound of Interest

Compound Name: *6-Butyl-2-methylpyridin-3-amine*

CAS No.: 1692608-20-0

Cat. No.: B2967955

[Get Quote](#)

In the landscape of neuropharmacology and medicinal chemistry, few molecules demonstrate the profound impact of subtle structural changes as elegantly as the aminopyridine isomers. This guide provides an in-depth comparative analysis of 2-aminopyridine, 3-aminopyridine, and 4-aminopyridine, detailing how the simple repositioning of an amino group on the pyridine ring dictates a cascade of distinct biological activities. We will explore the causality behind their differential mechanisms, present quantitative data, and provide validated experimental protocols for their assessment.

Introduction: The Isomeric Difference

Aminopyridines are a class of organic compounds existing as three structural isomers: 2-aminopyridine, 3-aminopyridine, and 4-aminopyridine.^{[1][2]} While sharing the same molecular formula (C₅H₆N₂), the position of the amino group fundamentally alters the electronic properties, basicity, and steric profile of each molecule.^[1] This, in turn, leads to dramatically different interactions with biological targets, most notably voltage-gated potassium (Kv) channels. 4-aminopyridine (4-AP) is a well-established Kv channel blocker used clinically to

treat symptoms of multiple sclerosis (MS).[3][4] In contrast, 2-aminopyridine and 3-aminopyridine exhibit a divergent and generally less potent pharmacological profile. Understanding these structure-activity relationships is paramount for the rational design of novel therapeutics.[5]

Comparative Mechanism of Action: A Tale of Three Isomers

The primary differentiator in the biological activity of aminopyridine isomers lies in their interaction with voltage-gated potassium channels, which are crucial for the repolarization of neuronal membranes.[6]

4-Aminopyridine (4-AP): The Potent Kv Channel Blocker

4-AP is a potent, non-selective blocker of voltage-gated potassium channels.[7] Its efficacy stems from its ability to enter the channel pore from the intracellular side in its charged (protonated) form, physically occluding the pathway for potassium ions.[8][9] This blockade delays the repolarization of the neuronal membrane, prolonging the action potential duration.[6] In demyelinated axons, as seen in MS, this prolonged depolarization allows for the activation of sufficient sodium channels to restore nerve impulse conduction.[7][10]

The mechanism is nuanced: the uncharged form of 4-AP crosses the cell membrane, and it is the intracellularly protonated, cationic form that acts on the Kv channels.[11] This action is use-dependent, meaning the channels must open for 4-AP to bind effectively within the pore.[8][9]

3-Aminopyridine (3-AP): A Less Potent Modulator

3-Aminopyridine also functions as a potassium channel blocker, though it is generally less potent than its 4-isomer.[12][13] Like 4-AP, it can enhance neurotransmitter release, particularly acetylcholine, which is a consequence of prolonging the presynaptic action potential.[12] However, its distinct geometry and electronic distribution result in a weaker interaction with the binding site within the potassium channel pore compared to 4-AP. It has been studied for its potential in treating neurological disorders but has not achieved the clinical success of 4-AP.[12]

2-Aminopyridine (2-AP): A Different Path

2-Aminopyridine is the least active of the three isomers as a direct potassium channel blocker. [13][14] Its biological activities are more diverse and less potent in the context of neuronal excitability. The 2-aminopyridine scaffold is a common pharmacophore, meaning it is a structural component of many biologically active compounds, including antihistamines and antibacterial agents.[4][15][16] While some studies suggest it can augment neuromuscular transmission, its primary role in modern drug discovery is often as a versatile starting material for synthesizing more complex molecules.[14][16][17] Its derivatives have been investigated for a wide range of activities, including antimicrobial, anticancer, and anti-inflammatory properties. [15][18][19]

Quantitative Comparison of Biological Activity

The most direct way to compare the primary activity of these isomers is through their half-maximal inhibitory concentration (IC50) against specific Kv channels.

Compound	Target Channel	IC50 (μM)	Relative Potency	Reference
4-Aminopyridine (4-AP)	Shaker K+ channels	235	1.0	[20]
4-Aminopyridine (4-AP)	mKv1.1	147 (extracellular)	-	[11]
4-Aminopyridine (4-AP)	Kv1.1	242	-	
3-Methyl-4-aminopyridine	Shaker K+ channels	34	~7-fold more potent	[21]
3-Fluoro-4-aminopyridine	Shaker K+ channels	240	Similar to 4-AP	[20]
3-Methoxy-4-aminopyridine	Shaker K+ channels	820	~3- to 4-fold less potent	[20][21]

Note: Direct, side-by-side comparative IC50 data for 2-AP and 3-AP against specific Kv channels under identical conditions is scarce in the literature, underscoring 4-AP's prominence

as the primary channel blocker in this family. The table includes 4-AP analogs to illustrate structure-activity relationships.

Visualizing the Mechanism and Workflow

To better understand the differential interaction and the experimental process to determine it, the following diagrams are provided.

Mechanism of Action: Differential Kv Channel Blockade

This diagram illustrates the proposed binding of the aminopyridine isomers to the intracellular pore of a voltage-gated potassium channel.

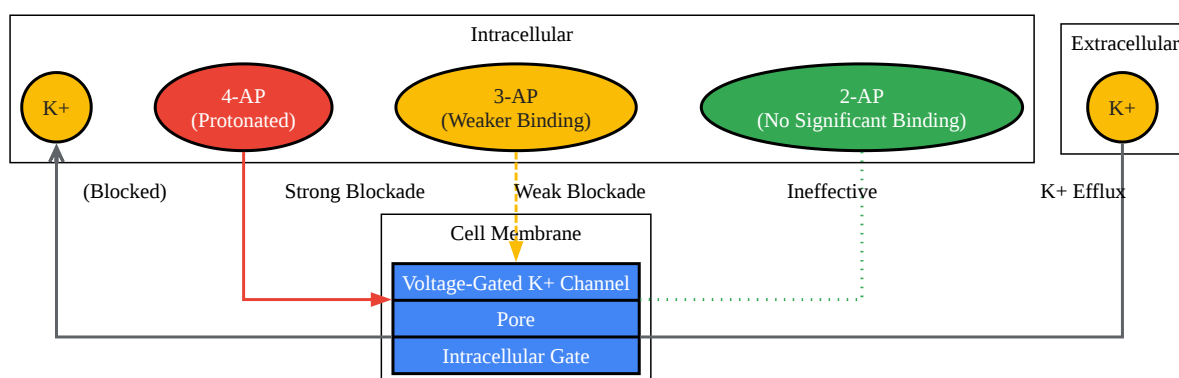

[Click to download full resolution via product page](#)

Caption: Differential binding of aminopyridine isomers to a Kv channel.

Experimental Workflow: Patch-Clamp Electrophysiology

The gold standard for assessing ion channel blockade is the patch-clamp technique. This workflow outlines the key steps for a comparative study.



[Click to download full resolution via product page](#)

Caption: Workflow for assessing ion channel modulation via patch-clamp.

Experimental Protocol: Whole-Cell Patch-Clamp Assay

This protocol provides a self-validating system to determine the IC₅₀ of aminopyridine isomers on a specific voltage-gated potassium channel (e.g., Kv1.1) expressed in a mammalian cell line.

Objective: To quantify and compare the inhibitory potency of 2-AP, 3-AP, and 4-AP on Kv1.1 channels.

Materials:

- Cell Line: HEK293 cells stably expressing human Kv1.1.
- External Solution (in mM): 140 NaCl, 4 KCl, 2 CaCl₂, 1 MgCl₂, 10 HEPES, 5 Glucose (pH adjusted to 7.4 with NaOH).
- Internal (Pipette) Solution (in mM): 140 KCl, 1 MgCl₂, 10 EGTA, 10 HEPES, 2 Mg-ATP (pH adjusted to 7.2 with KOH).
- Test Compounds: Stock solutions of 2-AP, 3-AP, and 4-AP in the external solution.

Methodology:

- Cell Preparation: Plate the Kv1.1-expressing HEK293 cells onto glass coverslips 24-48 hours before the experiment to achieve 50-70% confluency.
- Electrode Preparation: Pull borosilicate glass capillaries to a resistance of 2-5 MΩ when filled with the internal solution.

- Establishing Whole-Cell Configuration:
 - Transfer a coverslip to the recording chamber on the microscope stage and perfuse with the external solution.
 - Approach a single, healthy-looking cell with the patch pipette and apply gentle suction to form a high-resistance ($>1\text{ G}\Omega$) seal (giga-seal).
 - Apply a brief pulse of negative pressure to rupture the cell membrane under the pipette tip, achieving the whole-cell configuration. This provides electrical access to the cell's interior.
- Voltage-Clamp Protocol & Baseline Recording:
 - Hold the cell membrane potential at -80 mV .
 - Apply depolarizing voltage steps (e.g., from -60 mV to $+60\text{ mV}$ in 10 mV increments for 500 ms) to elicit outward K^+ currents through the $\text{Kv}1.1$ channels.
 - Record the stable baseline currents for at least 3 minutes to ensure the recording stability.
- Compound Application:
 - Begin perfusion with the external solution containing the lowest concentration of the first test isomer (e.g., $1\text{ }\mu\text{M}$ 4-AP).
 - Allow the solution to equilibrate for 2-3 minutes.
 - Record the currents using the same voltage-clamp protocol.
 - Repeat this process with increasing concentrations of the test isomer, allowing for a washout period with the external solution between different isomers if using the same cell.
- Data Analysis:
 - Measure the peak outward current at a specific voltage step (e.g., $+40\text{ mV}$) for each concentration.

- Normalize the current at each concentration to the baseline current to calculate the percentage of inhibition.
- Plot the percentage of inhibition against the logarithm of the compound concentration.
- Fit the data to a Hill equation to determine the IC50 value for each isomer.

Causality and Validation: The use of a stable cell line expressing a single, known ion channel ensures that the observed effects are target-specific. The establishment of a stable baseline before drug application validates that any subsequent change is due to the compound. The dose-response curve provides a quantitative measure of potency, allowing for direct and objective comparison between the isomers.

Therapeutic Implications and Conclusion

The profound difference in Kv channel blocking activity directly translates to their clinical utility. 4-Aminopyridine, under the name dalfampridine (Ampyra), is an FDA-approved treatment that improves walking in patients with multiple sclerosis by restoring conduction in demyelinated axons.[3][4][10] Its efficacy is a direct result of its potent potassium channel blockade.[7]

Conversely, 3-aminopyridine and 2-aminopyridine have not found a place as primary therapeutics for channelopathies.[12][16] While their derivatives are widely explored in medicinal chemistry for other targets, their weak interaction with Kv channels precludes them from applications where potent blockade is required.[1][15]

In conclusion, the aminopyridine isomers serve as a classic textbook example of a structure-activity relationship. The position of the amino group is the critical determinant of the molecule's ability to effectively bind to and block voltage-gated potassium channels. This single positional change separates a clinically effective neurological drug (4-AP) from its far less potent isomers (3-AP and 2-AP), providing a foundational lesson for researchers in the field of drug design and development.

References

- Mechanism of 4-aminopyridine action on voltage-gated potassium channels in lymphocytes. (n.d.). SpringerLink. Retrieved March 11, 2026, from [\[Link\]](#)

- On the Mechanism by which 4-Aminopyridine Occludes Quinidine Block of the Cardiac K + Channel, hKv1.5. (n.d.). Rockefeller University Press. Retrieved March 11, 2026, from [\[Link\]](#)
- A Model for 4-Aminopyridine Action on K Channels: Similarities to Tetraethylammonium Ion Action. (n.d.). ResearchGate. Retrieved March 11, 2026, from [\[Link\]](#)
- On the mechanism of 4-aminopyridine action on the cloned mouse brain potassium channel mKv1.1. (1995). National Center for Biotechnology Information. Retrieved March 11, 2026, from [\[Link\]](#)
- 4 aminopyridine – Knowledge and References. (n.d.). Taylor & Francis Online. Retrieved March 11, 2026, from [\[Link\]](#)
- 2-aminopyridine – a classic and trendy pharmacophore. (2017). International Journal of Pharma and Bio Sciences. Retrieved March 11, 2026, from [\[Link\]](#)
- 4-Aminopyridine. (n.d.). Wikipedia. Retrieved March 11, 2026, from [\[Link\]](#)
- 3-Aminopyridine: A Comprehensive Overview. (2025). NINGBO INNO PHARMCHEM CO.,LTD. Retrieved March 11, 2026, from [\[Link\]](#)
- 2-Aminopyridine – an unsung hero in drug discovery. (2021). Royal Society of Chemistry. Retrieved March 11, 2026, from [\[Link\]](#)
- Structure-activity relationship studies of four novel 4-aminopyridine K⁺ channel blockers. (2020). Nature.com. Retrieved March 11, 2026, from [\[Link\]](#)
- 4-Aminopyridine (4-AP). (n.d.). MP Biomedicals. Retrieved March 11, 2026, from [\[Link\]](#)
- Cracking the code: the clinical and molecular impact of aminopyridines; a review (2019–2024). (2025). Royal Society of Chemistry. Retrieved March 11, 2026, from [\[Link\]](#)
- Targeting Voltage-Gated Potassium Channels in Breast Cancer: Mechanistic Insights into 4-Aminopyridine-Induced Cell Death. (2025). MDPI. Retrieved March 11, 2026, from [\[Link\]](#)
- Syntheses, Complexation and Biological Activity of Aminopyridines: A Mini-Review. (2021). ResearchGate. Retrieved March 11, 2026, from [\[Link\]](#)

- Syntheses, Complexation and Biological Activity of Aminopyridines: A Mini-Review. (2021). Science Publishing Group. Retrieved March 11, 2026, from [\[Link\]](#)
- Concentrations of 4-aminopyridine and its two major metabolites that result in 50% inhibition of peak current of the recombinant potassium channels K v 1.1, K v 1.2, and K v 1.4. (n.d.). ResearchGate. Retrieved March 11, 2026, from [\[Link\]](#)
- Synthesis of 2-aminopyridine Lactones and Studies of Their Antioxidant, Antibacterial and Antifungal Properties. (2021). MDPI. Retrieved March 11, 2026, from [\[Link\]](#)
- Efficient Synthesis of 2-Aminopyridine Derivatives: Antibacterial Activity Assessment and Molecular Docking Studies. (n.d.). National Center for Biotechnology Information. Retrieved March 11, 2026, from [\[Link\]](#)
- Neuroprotective Properties of 4-Aminopyridine. (2021). Neurology: Neuroimmunology & Neuroinflammation. Retrieved March 11, 2026, from [\[Link\]](#)
- 2-Aminopyridine – an unsung hero in drug discovery. (n.d.). Royal Society of Chemistry. Retrieved March 11, 2026, from [\[Link\]](#)
- Synthesis and Biological Activity of 3- and 5-Amino Derivatives of Pyridine-2-carboxaldehyde Thiosemicarbazone. (n.d.). ACS Publications. Retrieved March 11, 2026, from [\[Link\]](#)
- Synthesis and biological activities of 3-aminoimidazo[1,2- α]pyridine compounds. (2025). National Center for Biotechnology Information. Retrieved March 11, 2026, from [\[Link\]](#)
- Theoretical Analysis of the Molecular Determinants Responsible for the K(+) Channel Blocking by Aminopyridines. (2001). National Center for Biotechnology Information. Retrieved March 11, 2026, from [\[Link\]](#)
- A high-affinity, partial antagonist effect of 3,4-diaminopyridine mediates action potential broadening and enhancement of transmitter release at NMJs. (n.d.). National Center for Biotechnology Information. Retrieved March 11, 2026, from [\[Link\]](#)
- Synthesis and Biological Study of 4-Aminopyridine-Peptide Derivatives Designed for the Treatment of Neurodegenerative Disorders. (2023). National Center for Biotechnology Information. Retrieved March 11, 2026, from [\[Link\]](#)

- Structure-activity relationship studies of three novel 4-aminopyridine K⁺ channel blockers. (2019). bioRxiv. Retrieved March 11, 2026, from [\[Link\]](#)
- 2-Aminopyridine - An unsung hero in drug discovery. (n.d.). ResearchGate. Retrieved March 11, 2026, from [\[Link\]](#)
- 4-methyl-3-aminopyridine: A novel active blocker of voltage-gated potassium ion channels in the central nervous system. (2026). bioRxiv. Retrieved March 11, 2026, from [\[Link\]](#)
- Aminopyridines Potentiate Synaptic and Neuromuscular Transmission by Targeting the Voltage-activated Calcium Channel β Subunit. (n.d.). National Center for Biotechnology Information. Retrieved March 11, 2026, from [\[Link\]](#)
- 2-Aminopyridine. (n.d.). PubChem. Retrieved March 11, 2026, from [\[Link\]](#)
- Class III Antiarrhythmics (Potassium Channel Blockers). (n.d.). CVPharmacology. Retrieved March 11, 2026, from [\[Link\]](#)
- Electrophysiological analysis of cardiac KATP channel. (n.d.). National Center for Biotechnology Information. Retrieved March 11, 2026, from [\[Link\]](#)
- In vivo electrophysiological effects of a selective slow delayed-rectifier potassium channel blocker in anesthetized dogs: potential insights into class III actions. (2004). Oxford Academic. Retrieved March 11, 2026, from [\[Link\]](#)
- Modulation of potassium channels by antiarrhythmic and antihypertensive drugs. (1990). SemanticScholar.org. Retrieved March 11, 2026, from [\[Link\]](#)
- Potassium Channel Blockade Enhances Atrial Fibrillation–Selective Antiarrhythmic Effects of Optimized State-Dependent Sodium Channel Blockade. (2015). Circulation. Retrieved March 11, 2026, from [\[Link\]](#)
- Efficient Synthesis of 2-Aminopyridine Derivatives: Antibacterial Activity Assessment and Molecular Docking Studies. (2022). Semantic Scholar. Retrieved March 11, 2026, from [\[Link\]](#)

Need Custom Synthesis?

BenchChem offers custom synthesis for rare earth carbides and specific isotopic labeling.

Email: info@benchchem.com or [Request Quote Online](#).

Sources

- 1. Syntheses, Complexation and Biological Activity of Aminopyridines: A Mini-Review, American Journal of Heterocyclic Chemistry, Science Publishing Group [sciencepublishinggroup.com]
- 2. [researchgate.net](https://www.researchgate.net) [[researchgate.net](https://www.researchgate.net)]
- 3. 4-Aminopyridine - Wikipedia [en.wikipedia.org]
- 4. Cracking the code: the clinical and molecular impact of aminopyridines; a review (2019–2024) - RSC Advances (RSC Publishing) DOI:10.1039/D4RA07438F [pubs.rsc.org]
- 5. [benchchem.com](https://www.benchchem.com) [[benchchem.com](https://www.benchchem.com)]
- 6. CV Pharmacology | Class III Antiarrhythmics (Potassium Channel Blockers) [[cvpharmacology.com](https://www.cvpharmacology.com)]
- 7. [taylorandfrancis.com](https://www.taylorandfrancis.com) [[taylorandfrancis.com](https://www.taylorandfrancis.com)]
- 8. Mechanism of 4-aminopyridine action on voltage-gated potassium channels in lymphocytes - PMC [pubmed.ncbi.nlm.nih.gov]
- 9. [researchgate.net](https://www.researchgate.net) [[researchgate.net](https://www.researchgate.net)]
- 10. [neurology.org](https://www.neurology.org) [[neurology.org](https://www.neurology.org)]
- 11. On the mechanism of 4-aminopyridine action on the cloned mouse brain potassium channel mKv1.1 - PMC [pubmed.ncbi.nlm.nih.gov]
- 12. [nbinno.com](https://www.nbinno.com) [[nbinno.com](https://www.nbinno.com)]
- 13. Theoretical analysis of the molecular determinants responsible for the K(+) channel blocking by aminopyridines - PubMed [pubmed.ncbi.nlm.nih.gov]
- 14. 2-Aminopyridine | NH₂C₅H₄N | CID 10439 - PubChem [pubchem.ncbi.nlm.nih.gov]
- 15. [ijpbs.net](https://www.ijpbs.net) [[ijpbs.net](https://www.ijpbs.net)]
- 16. 2-Aminopyridine – an unsung hero in drug discovery - Chemical Communications (RSC Publishing) [pubs.rsc.org]

- [17. 2-Aminopyridine – an unsung hero in drug discovery - Chemical Communications \(RSC Publishing\) \[pubs.rsc.org\]](#)
- [18. mdpi.com \[mdpi.com\]](#)
- [19. Efficient Synthesis of 2-Aminopyridine Derivatives: Antibacterial Activity Assessment and Molecular Docking Studies - PMC \[pmc.ncbi.nlm.nih.gov\]](#)
- [20. benchchem.com \[benchchem.com\]](#)
- [21. Structure-activity relationship studies of three novel 4-aminopyridine K⁺ channel blockers | bioRxiv \[biorxiv.org\]](#)
- To cite this document: BenchChem. [A Comparative Analysis of Aminopyridine Isomers' Biological Activity: A Guide for Researchers]. BenchChem, [2026]. [Online PDF]. Available at: [<https://www.benchchem.com/product/b2967955/docs#a-comparative-analysis-of-aminopyridine-isomers-biological-activity-a-guide-for-researchers>]

Disclaimer & Data Validity:

The information provided in this document is for Research Use Only (RUO) and is strictly not intended for diagnostic or therapeutic procedures. While BenchChem strives to provide accurate protocols, we make no warranties, express or implied, regarding the fitness of this product for every specific experimental setup.

Technical Support: The protocols provided are for reference purposes. Unsure if this reagent suits your experiment?

Need Industrial/Bulk Grade? [Request Custom Synthesis Quote](#)

BenchChem

Our mission is to be the trusted global source of essential and advanced chemicals, empowering scientists and researchers to drive progress in science and industry.

Contact

Address: 3281 E Guasti Rd
Ontario, CA 91761, United States
Phone: (601) 213-4426
Email: info@benchchem.com

Contact our Ph.D. Support Team for a compatibility check