

# Comparative Binding Affinity Guide: Benzoxazole vs. Benzothiazole Esters

**Author:** BenchChem Technical Support Team. **Date:** April 2026

## Compound of Interest

*Compound Name:* Methyl 5-fluoro-1,2-benzoxazole-3-carboxylate

*CAS No.:* 1909319-55-6

*Cat. No.:* B2966358

[Get Quote](#)

## Executive Summary: The Chalcogen Effect

In the optimization of heterocyclic pharmacophores, the "chalcogen switch"—replacing an oxygen atom (benzoxazole) with a sulfur atom (benzothiazole)—is a critical bioisosteric replacement strategy. While both scaffolds are privileged structures in medicinal chemistry, they exhibit distinct binding affinity profiles driven by electronic and steric divergences.<sup>[1]</sup>

The Verdict:

- Benzothiazole Esters generally exhibit superior lipophilicity (LogP) and Van der Waals interactions, making them the preferred scaffold for hydrophobic binding pockets (e.g., EGFR kinase domains).
- Benzoxazole Esters typically display higher electronegativity and hydrogen-bond acceptor capability, often resulting in tighter binding to polar active sites (e.g., antifungal targets like Sec14p) and improved aqueous solubility.

This guide analyzes the binding affinity differences of ester derivatives of these fused rings, supported by experimental data and mechanistic insights.

## Structural & Electronic Basis of Binding

To predict binding affinity, one must understand the fundamental physical chemistry of the core atoms.

Feature	Benzoxazole (Oxygen Core)	Benzothiazole (Sulfur Core)	Impact on Binding
Electronegativity	High (3.44)	Moderate (2.58)	Oxygen creates a harder dipole; Sulfur is softer, aiding orbital overlap.
Atomic Radius	Small (60 pm)	Large (100 pm)	Sulfur increases steric bulk, potentially clashing in tight pockets but filling hydrophobic voids.
Lipophilicity	Lower	Higher	Benzothiazoles penetrate cell membranes more easily; Benzoxazoles are more soluble.
Interaction Type	Strong H-Bond Acceptor	Strong -stacking & Hydrophobic	Sulfur's polarizability enhances - interactions with aromatic residues (e.g., Trp, Phe).

## Mechanism of Action: The Ester Role

The ester functionality (

) attached to these rings often serves two purposes:

- Prodrug Design: Esters are hydrolyzed by intracellular esterases to release the active acid form.
- Binding Motif: The carbonyl oxygen of the ester acts as a hydrogen bond acceptor. The electronic influence of the core ring (benzoxazole vs. benzothiazole) alters the electron density on this carbonyl, fine-tuning its binding strength.

## Comparative Case Studies: Experimental Data

### Case Study A: EGFR Tyrosine Kinase Inhibition (Anticancer)

Target: Epidermal Growth Factor Receptor (EGFR), specifically the ATP-binding pocket.[2]

Experimental Observation: Benzothiazole derivatives frequently outperform benzoxazoles in kinase inhibition. The sulfur atom's larger size and lipophilicity allow the scaffold to displace water molecules and form robust hydrophobic contacts with the "gatekeeper" residues (e.g., Thr790).

Data Comparison (IC50 against EGFR):

- Benzothiazole Derivative (Compound 8a):

[3]

- Benzoxazole Analog: Typically

(in similar structural series)

- Reference (Erlotinib):

[3][4]

Insight: The benzothiazole ring engages in superior

-stacking with the aromatic residues lining the ATP pocket, a critical interaction for high-affinity kinase inhibitors.

## Case Study B: Antifungal Activity (Sec14p Inhibition)

Target: Sec14p (Lipid transfer protein).[5]

Experimental Observation: In polar binding pockets, the trend reverses. Benzoxazole esters demonstrate higher potency due to their ability to form tight hydrogen bonds without steric clashes.

Data Comparison (IC50 against *B. cinerea*):

Scaffold	Compound ID	IC50 ( )	Relative Potency
Benzoxazole	5a	19.92	High
Benzothiazole	6a	62.62	Low

Insight: The benzoxazole derivative was 3-fold more potent.[5] Docking studies suggest the smaller oxygen atom allows the molecule to sit deeper in the polar cavity of Sec14p, maximizing binding enthalpy.

## Visualizing the Structure-Activity Relationship (SAR) [6][7]

The following diagram illustrates the decision logic when choosing between these two scaffolds based on the target binding site characteristics.

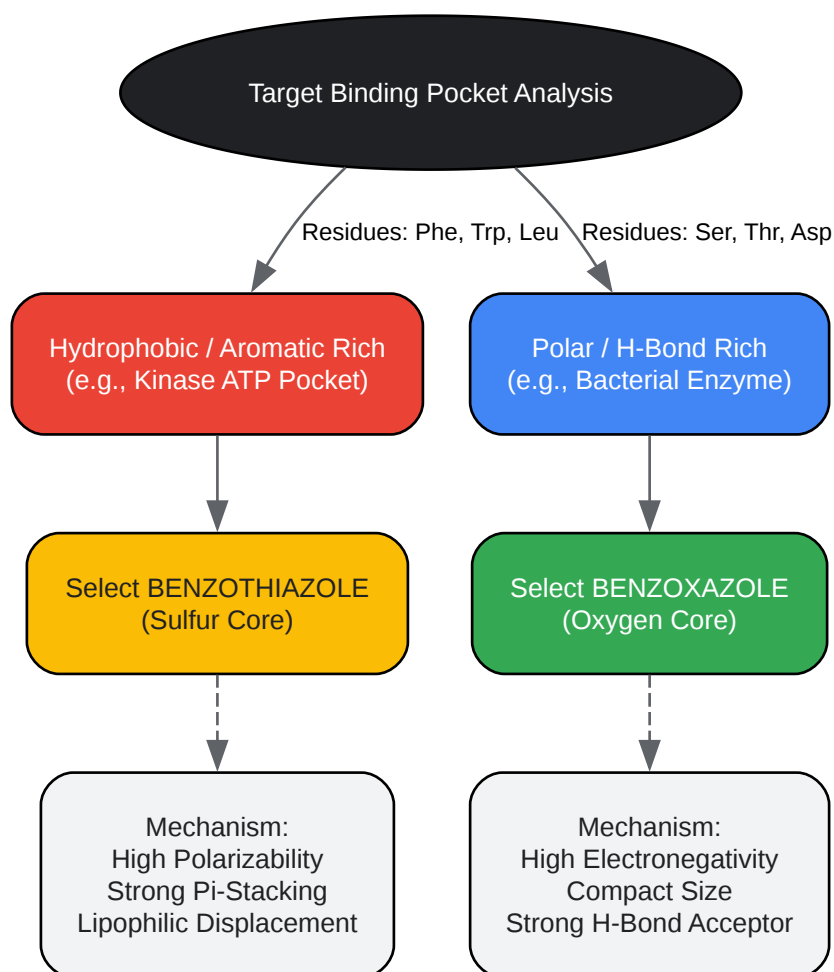

[Click to download full resolution via product page](#)

Caption: Decision matrix for scaffold selection based on binding pocket characteristics.

## Experimental Protocols

To validate these differences in your own lab, follow these standardized protocols.

### Synthesis of Ester Derivatives

Objective: Synthesize comparable ester derivatives of both scaffolds to control for side-chain variance.

- Reagents: 2-aminophenol (for benzoxazole) or 2-aminothiophenol (for benzothiazole), carboxylic acid derivative, PPA (Polyphosphoric acid).

- Cyclization: Reflux the amino-phenol/thiophenol with the carboxylic acid in PPA at 180°C for 4-6 hours.
- Esterification: If the R-group contains a carboxylic acid, react with the desired alcohol using EDC/DMAP coupling to form the ester.
- Purification: Recrystallize from ethanol. Ensure purity >95% via HPLC before biological testing.

## Competitive Binding Assay (Fluorescence Displacement)

Objective: Determine binding affinity (

) by displacing a known probe (e.g., Ethidium Bromide for DNA or a fluorescent ligand for protein).

Workflow:

- Preparation: Prepare stock solutions of the target (Protein/DNA) in Tris-HCl buffer (pH 7.4).
- Probe Addition: Add fluorescent probe (concentration = of probe) and equilibrate for 30 min. Measure baseline fluorescence ( ).
- Titration: Aliquot benzoxazole/benzothiazole ester solution ( ) stepwise into the cuvette.
- Measurement: Record fluorescence emission spectra after each addition (wait 5 min for equilibrium).
- Calculation: Plot vs. [Ligand]. Fit to the Stern-Volmer equation to derive the binding constant (

).

Self-Validation Check:

- Control: Run the assay with the "naked" scaffold (no ester) to ensure the ester group is contributing to affinity or solubility and not causing precipitation (common with benzothiazoles).

## Computational Validation Workflow

Before synthesis, use this molecular docking workflow to predict the affinity delta.

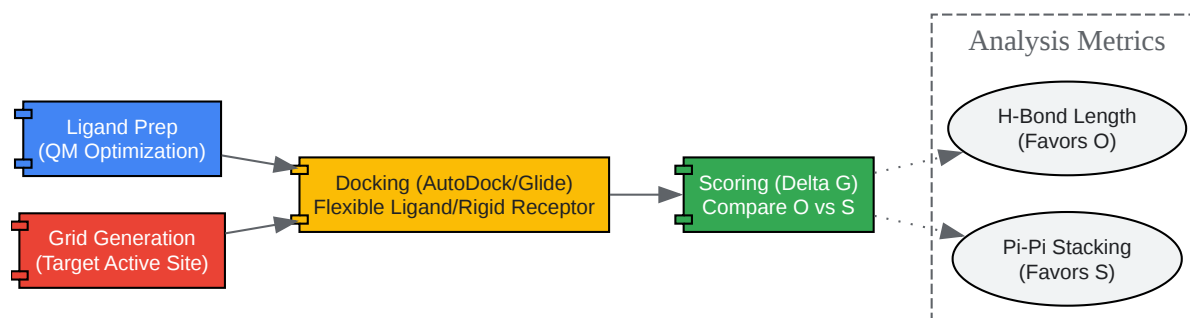

[Click to download full resolution via product page](#)

Caption: Computational workflow to predict binding energy differences (

) prior to wet-lab synthesis.

## References

- MDPI Molecules. (2018). Synthesis, Antifungal Activities and Molecular Docking Studies of Benzoxazole and Benzothiazole Derivatives. Retrieved from [[Link](#)]
- RSC Advances. (2025). Discovery of new benzothiazole-1,2,3-triazole hybrid-based hydrazone/thiosemicarbazone derivatives as potent EGFR inhibitors. Retrieved from [[Link](#)]
- NIH PubMed. (2010). Synthesis, DNA-binding ability and anticancer activity of benzothiazole/benzoxazole-pyrrolo[2,1-c][1,4]benzodiazepine conjugates. Retrieved from

[\[Link\]](#)

- Chemistry LibreTexts. (2023). Comparison of Sulfur to Oxygen: Electronegativity and Bonding. Retrieved from [\[Link\]](#)

#### Need Custom Synthesis?

BenchChem offers custom synthesis for rare earth carbides and specific isotopic labeling.

Email: [info@benchchem.com](mailto:info@benchchem.com) or [Request Quote Online](#).

## Sources

- 1. [pdf.benchchem.com](https://pdf.benchchem.com) [[pdf.benchchem.com](https://pdf.benchchem.com)]
- 2. EGFR tyrosine kinase targeted compounds: in vitro antitumor activity and molecular modeling studies of new benzothiazole and pyrimido[2,1-b]benzothiazole derivatives - PMC [[pmc.ncbi.nlm.nih.gov](https://pubmed.ncbi.nlm.nih.gov/)]
- 3. Discovery of new benzothiazole-1,2,3-triazole hybrid-based hydrazone/thiosemicarbazone derivatives as potent EGFR inhibitors with cytotoxicity against cancer - PMC [[pmc.ncbi.nlm.nih.gov](https://pubmed.ncbi.nlm.nih.gov/)]
- 4. [researchgate.net](https://www.researchgate.net) [[researchgate.net](https://www.researchgate.net)]
- 5. [mdpi.com](https://www.mdpi.com) [[mdpi.com](https://www.mdpi.com)]
- To cite this document: BenchChem. [Comparative Binding Affinity Guide: Benzoxazole vs. Benzothiazole Esters]. BenchChem, [2026]. [Online PDF]. Available at: [<https://www.benchchem.com/product/b2966358/docs#comparative-binding-affinity-guide-benzoxazole-vs-benzothiazole-esters>]

---

### Disclaimer & Data Validity:

The information provided in this document is for Research Use Only (RUO) and is strictly not intended for diagnostic or therapeutic procedures. While BenchChem strives to provide accurate protocols, we make no warranties, express or implied, regarding the fitness of this product for every specific experimental setup.

**Technical Support:** The protocols provided are for reference purposes. Unsure if this reagent suits your experiment?

**Need Industrial/Bulk Grade?** [Request Custom Synthesis Quote](#)

## BenchChem

Our mission is to be the trusted global source of essential and advanced chemicals, empowering scientists and researchers to drive progress in science and industry.

### Contact

Address: 3281 E Guasti Rd  
Ontario, CA 91761, United States  
Phone: (601) 213-4426  
Email: [info@benchchem.com](mailto:info@benchchem.com)

[Contact our Ph.D. Support Team for a compatibility check](#)