

# Technical Guide: Physical Properties & Characterization of Fluorinated Nitroaniline Derivatives

**Author:** BenchChem Technical Support Team. **Date:** April 2026

## Compound of Interest

Compound Name:	4-Fluoro-N,N-dimethyl-3-nitroaniline
CAS No.:	18542-98-8
Cat. No.:	B2962244

[Get Quote](#)

## Executive Summary

Fluorinated nitroaniline derivatives represent a critical intersection between medicinal chemistry and materials science. Structurally, they serve as "push-pull" systems where the electron-donating amine (

) and electron-withdrawing nitro (

) groups create a strong dipole, modulated by the high electronegativity and small Van der Waals radius of the fluorine substituent.<sup>[1]</sup>

For drug development professionals, these derivatives are invaluable bioisosteres; the fluorine atom blocks metabolic labile sites (preventing oxidative metabolism) while modulating lipophilicity (

) and acidity (

). In materials science, non-centrosymmetric crystal packing of these derivatives yields exceptional Non-Linear Optical (NLO) properties, specifically Second Harmonic Generation (SHG).

This guide moves beyond basic data listing to explore the causality of these physical properties and provides self-validating protocols for their characterization.

## The Fluorine Effect: Electronic & Structural Mechanics

To understand the physical properties, one must first grasp the electronic environment. The introduction of fluorine onto the nitroaniline scaffold induces two competing effects:

- Inductive Withdrawal ( ): Fluorine is the most electronegative element, pulling electron density through the sigma bond framework. This drastically reduces the basicity of the aniline nitrogen.
- Mesomeric Donation ( ): To a lesser extent, fluorine's lone pairs can donate into the -system, though the effect dominates in this scaffold.[1]

## The "Push-Pull" Chromophore

The high hyperpolarizability (

) of these molecules arises from the charge transfer (CT) between the amine donor and nitro acceptor.[2] Fluorine modifies this CT energy gap.[1]

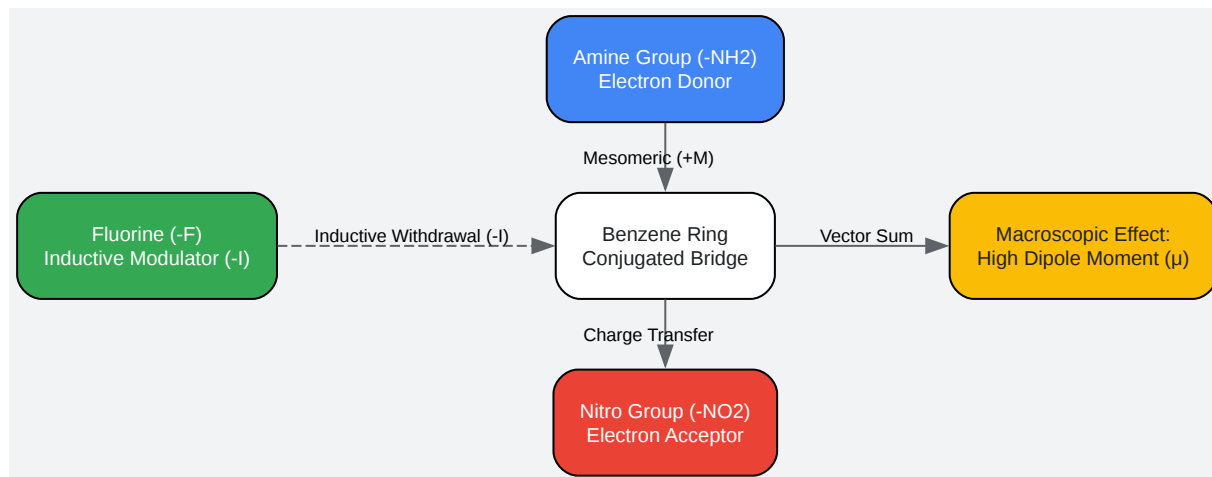

[Click to download full resolution via product page](#)

Figure 1: The electronic "Push-Pull" mechanism governing the NLO and spectroscopic properties of fluorinated nitroanilines.

## Physicochemical Profiling

The following data compares the parent compound (Aniline) with the nitro-derivative and the fluoro-nitro-derivative to illustrate the substituent effects.

## Comparative Properties Table

Property	Aniline	4-Nitroaniline	2-Fluoro-4-nitroaniline	Causality / Insight
CAS	62-53-3	100-01-6	369-35-7	—
MW ( g/mol )	93.13	138.12	156.11	Fluorine adds mass but minimal steric bulk ( ).[1]
Melting Point	-6 °C	146-148 °C	132-134 °C	Symmetry breaking by F lowers lattice energy compared to highly symmetric 4-nitroaniline.[1]
(Conj. Acid)	4.6	1.0	~ -0.5 (Predicted)	Critical: The -I effect of F ortho to makes the amine essentially non-basic.[1]
(Lipophilicity)	0.9	1.4	1.9 - 2.1	F increases lipophilicity, enhancing membrane permeability (bioisostere effect).
Appearance	Colorless Oil	Yellow Solid	Brown/Orange Solid	Solvatochromic shift due to intramolecular Charge Transfer (ICT).

## Solubility & Lipophilicity

Fluorination typically increases lipophilicity (

) by approximately 0.5–0.8 units compared to the hydrogen analog. This is crucial in drug design:

- Mechanism: The C-F bond is non-polarizable and has low solvation energy in water (hydrophobic).
- Implication: 2-Fluoro-4-nitroaniline is sparingly soluble in water but highly soluble in polar organic solvents (DMSO, Ethyl Acetate, Methanol).[1]

## Advanced Characterization Protocols

For researchers synthesizing these derivatives, standard characterization (NMR/MS) is insufficient due to the unique properties of the C-F bond.

### A. NMR Spectroscopy ( and ) [3]

- NMR: This is the gold standard for purity. The fluorine signal is highly sensitive to the chemical environment.
  - Expectation: A singlet or multiplet (if proton-coupled) around -110 to -130 ppm (relative to ).[1]
  - Coupling: Observe coupling (approx. 8-10 Hz) in the proton spectrum. This validates the position of the fluorine relative to aromatic protons.

### B. Spectrophotometric Determination (Method for Weak Bases)

Standard potentiometric titration fails for these derivatives because their basicity is too low ( ).

Protocol:

- Preparation: Dissolve

M of the derivative in water/methanol (co-solvent may be needed).

- Acidification: Titrate with concentrated

or

while monitoring UV-Vis absorbance.

- Detection: The unprotonated "push-pull" system has a strong

(approx 350-400 nm).[1] Protonation of the amine destroys the charge transfer, causing a hypsochromic (blue) shift or disappearance of the peak.

- Calculation: Use the Henderson-Hasselbalch equation adapted for spectrophotometry:

Where

is absorbance at a specific pH.

## Experimental Workflow: High-Purity Isolation

For NLO applications or pharmaceutical standards, purity >99.5% is required.[1] The high dipole moment makes these compounds "sticky" on silica columns.

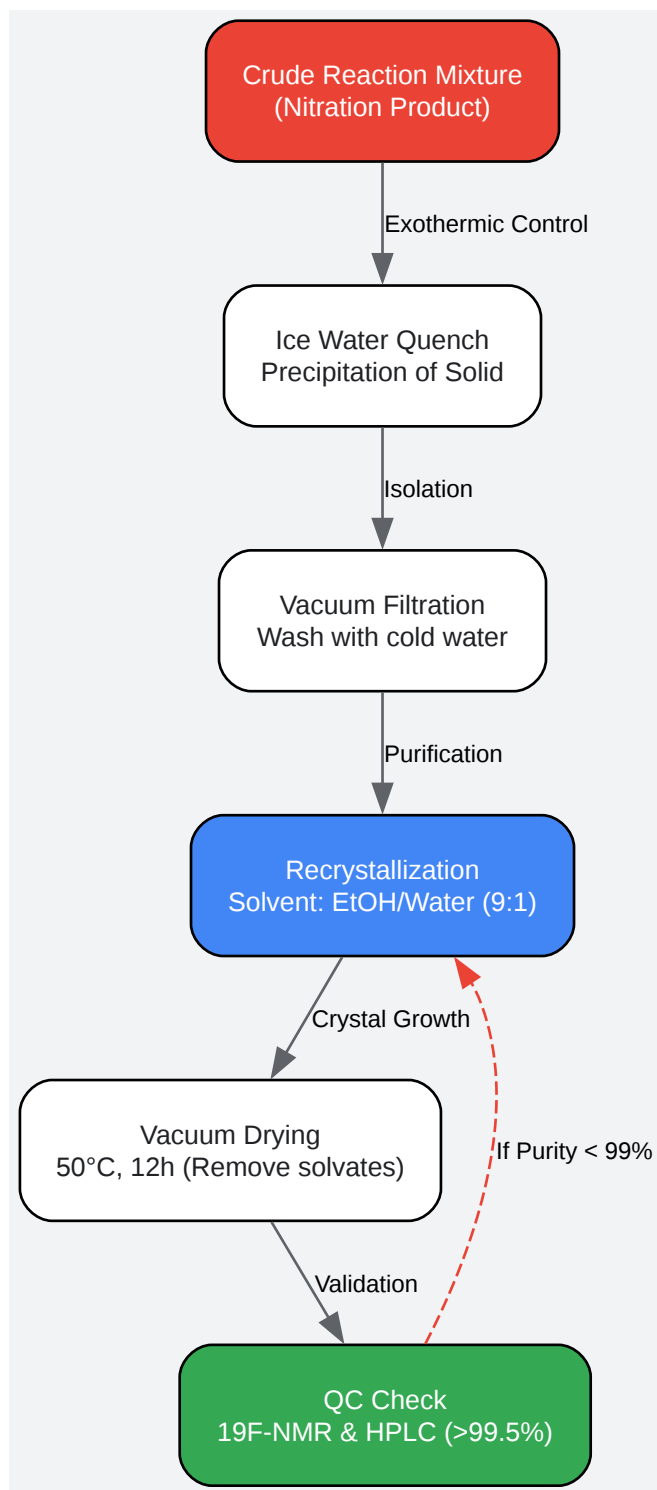

[Click to download full resolution via product page](#)

Figure 2: Optimized purification workflow for isolating high-purity fluorinated nitroanilines, prioritizing the removal of ionic byproducts.

## Protocol Note: Recrystallization

- Why Ethanol/Water? Nitroanilines are highly soluble in hot ethanol but poorly soluble in water.[1] The 9:1 mixture allows for a "cooling crystallization" that yields defined prisms suitable for X-ray diffraction, rather than amorphous powder.
- Warning: Avoid chlorinated solvents for final recrystallization if NLO properties are being tested, as solvent inclusion can disrupt the non-centrosymmetric packing.

## References

- BenchChem. (2025).[1][3] 4-Fluoro-3-nitroaniline: Technical Overview and Applications. Retrieved from
- Smolecule. (2023).[1] Synthesis and Properties of 3-Fluoro-4-nitroaniline. Retrieved from
- Ossila. (2023).[1] 2-Fluoro-4-nitroaniline: Material Specifications for Optoelectronics. Retrieved from
- EPA CompTox Dashboard. (2023). Physicochemical Data for Fluorinated Nitroanilines. Retrieved from
- Wang, Z., et al. (2023).[4] Lipophilicity Modulations by Fluorination Correlate with Membrane Partitioning. *Angewandte Chemie International Edition*. Retrieved from
- Kumar, K., et al. (2018). Growth and Characterization of Promising NLO Crystal: Meta Nitroaniline. *Rasayan Journal of Chemistry*. Retrieved from

### *Need Custom Synthesis?*

*BenchChem offers custom synthesis for rare earth carbides and specific isotopic labeling.*

*Email: [info@benchchem.com](mailto:info@benchchem.com) or [Request Quote Online](#).*

## Sources

- [1. US3586719A - Process for preparing 4-fluoro-3-nitroaniline - Google Patents \[patents.google.com\]](#)

- [2. researchgate.net \[researchgate.net\]](https://researchgate.net)
- [3. 4-Fluoro-3-nitroaniline | 364-76-1 | Benchchem \[benchchem.com\]](https://www.benchchem.com)
- [4. eprints.soton.ac.uk \[eprints.soton.ac.uk\]](https://eprints.soton.ac.uk)
- To cite this document: BenchChem. [Technical Guide: Physical Properties & Characterization of Fluorinated Nitroaniline Derivatives]. BenchChem, [2026]. [Online PDF]. Available at: [\[https://www.benchchem.com/product/b2962244/docs#technical-guide-physical-properties-characterization-of-fluorinated-nitroaniline-derivatives\]](https://www.benchchem.com/product/b2962244/docs#technical-guide-physical-properties-characterization-of-fluorinated-nitroaniline-derivatives)

### Disclaimer & Data Validity:

The information provided in this document is for Research Use Only (RUO) and is strictly not intended for diagnostic or therapeutic procedures. While BenchChem strives to provide accurate protocols, we make no warranties, express or implied, regarding the fitness of this product for every specific experimental setup.

**Technical Support:** The protocols provided are for reference purposes. Unsure if this reagent suits your experiment?

**Need Industrial/Bulk Grade?** [Request Custom Synthesis Quote](#)

## BenchChem

Our mission is to be the trusted global source of essential and advanced chemicals, empowering scientists and researchers to drive progress in science and industry.

### Contact

Address: 3281 E Guasti Rd  
Ontario, CA 91761, United States  
Phone: (601) 213-4426  
Email: [info@benchchem.com](mailto:info@benchchem.com)

[Contact our Ph.D. Support Team for a compatibility check](#)

