

# Spectroscopic Profiling of Fluorinated $\alpha$ -Amino Esters: A Comparative Technical Guide

**Author:** BenchChem Technical Support Team. **Date:** May 2026

## Compound of Interest

Compound Name: Ethyl 3-amino-3-(2,4-difluorophenyl)propanoate

CAS No.: 502842-41-3

Cat. No.: B2926678

[Get Quote](#)

## Strategic Context: The Fluorine Bioisostere

In drug discovery,

$\alpha$ -amino acids are pivotal for constructing peptidomimetics with enhanced proteolytic stability.[1]  
[2] The introduction of fluorine into the

$\alpha$ -amino ester scaffold serves two primary functions: modulation of basicity (pKa) and alteration of lipophilicity (

)). However, the position of the fluorine atom—whether at the

$\alpha$ -position (C2) or as a trifluoromethyl group at the

$\beta$ -position (C3)—drastically alters the spectroscopic footprint and stereochemical behavior of the molecule.

This guide contrasts the two most chemically significant classes:

- Class A:

-Fluoro-

-amino esters (Fluorine at C2; Amine at C3).[1][2]

- Class B:

-(Trifluoromethyl)-

-amino esters (

at C3; Amine at C3).[1][2]

## Comparative Spectroscopic Analysis

The following data consolidates NMR and IR characteristics observed in representative ethyl ester derivatives.

### Table 1: Spectroscopic Signatures of Fluorinated -Amino Esters[2][3]

Feature	Class A:	Class B:	Non-Fluorinated Control
	-Fluoro-	-	
-amino ester		-amino ester	
Structure			
NMR (α-H)	4.8 – 5.2 ppm (dd or ddd)	2.6 – 2.9 ppm (m, diastereotopic)	2.4 – 2.6 ppm
NMR (β-H)	3.5 – 4.0 ppm (m)	3.8 – 4.2 ppm (m)	3.2 – 3.5 ppm
NMR (Carbonyl)	-190 to -210 ppm (ddd)	-75 to -80 ppm (d or s)	N/A
(Geminal)	46 – 52 Hz (Characteristic)	N/A	N/A
(Vicinal)	12 – 28 Hz (Stereo-dependent)	7 – 9 Hz	N/A
IR (C=O)	1745 – 1755 (α-effect)	1735 – 1745	~1730
pKa (Conj. Acid)	~7.5 – 8.0 (Inductive withdrawal)	~5.5 – 6.5 (Strong withdrawal)	~9.0 – 9.5

## Key Mechanistic Insights[1][3]

- The

-Effect on Carbonyls: In Class A, the fluorine atom is geminal to the carbonyl.[1] The strong inductive effect (

) pulls electron density from the ester carbonyl, increasing the double-bond character and shifting the IR stretch to higher frequencies (

).

- Basicity Modulation: Class B compounds exhibit a significantly lower pKa.[1][2] The

group is a powerful electron-withdrawing group (EWG) attached directly to the amine-bearing carbon, destabilizing the ammonium cation more effectively than the

-fluorine in Class A, which is one bond further away.

## Stereochemical Assignment Workflow

The most critical analytical challenge is distinguishing syn and anti diastereomers in Class A compounds.[1] This relies heavily on the Karplus-like dependence of vicinal coupling constants (

(

).[1]

## The Coupling Constant Rule

- Anti-isomer: The H-C(

)C(

)-H dihedral angle is typically

.[1][2] This results in large

values (8–11 Hz).[1]

- Syn-isomer: The dihedral angle is

, resulting in small

values (2–5 Hz).[1]

- Fluorine Coupling:

also varies but is often larger in the anti arrangement (

Hz) compared to syn (

Hz), though this can be complicated by rotamer populations.

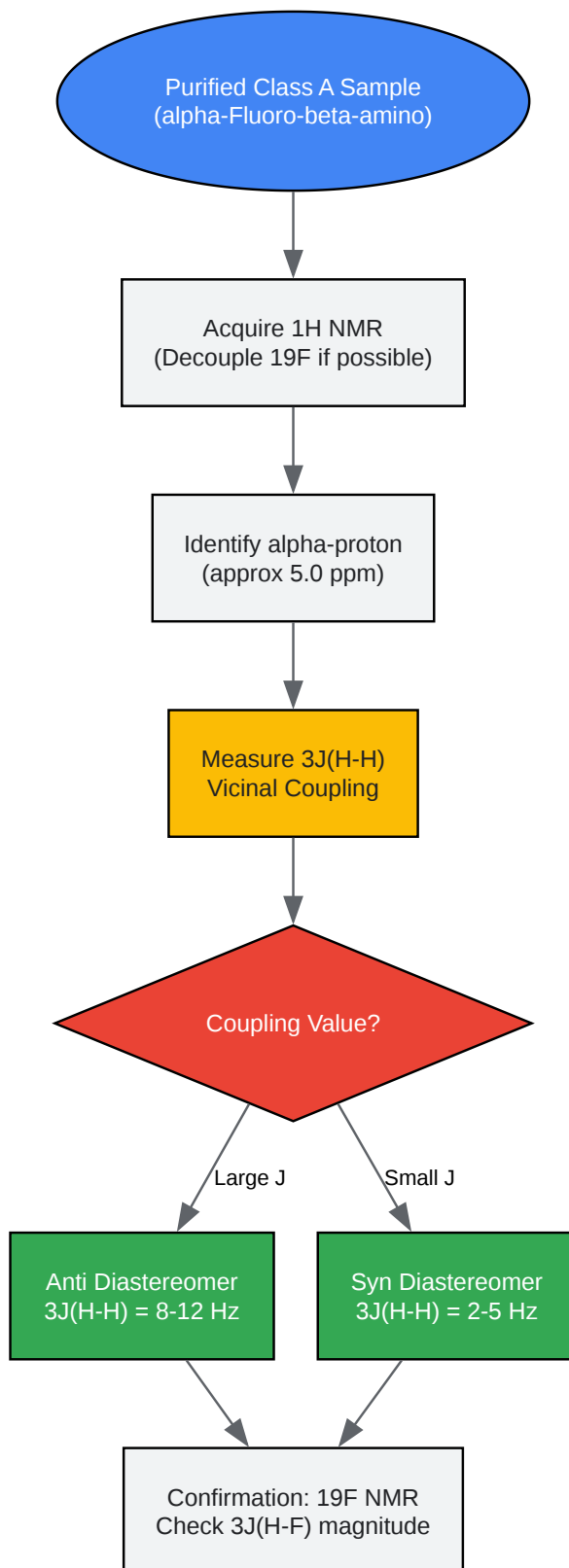

[Click to download full resolution via product page](#)

Figure 1: Decision tree for stereochemical assignment of

-fluoro-

-amino esters based on vicinal proton coupling constants.

## Experimental Protocols

### NMR Sample Preparation & Acquisition

Fluorinated amines are sensitive to pH and concentration effects due to hydrogen bonding.[1]

[2]

- Solvent Selection: Use

for routine analysis.[1] However, if signal overlap occurs, switch to

(Benzene-d6). The aromatic solvent induced shift (ASIS) often resolves the

-proton from the

-proton multiplets.[1][2]

- Sample Concentration: Prepare at

. Higher concentrations can lead to aggregation, broadening the amine signals.

- Acquisition Parameters:

- : Minimum 16 scans.[1] Relaxation delay (

)

s to ensure accurate integration of protons near fluorine (which may have different times).

- : Spectral width must cover -50 to -250 ppm.[1] Reference against internal

(

ppm) or

-trifluorotoluene (

ppm).

- Decoupling: Run a

experiment to simplify the

-proton splitting pattern. This collapses the complex ddd to a simpler dd, revealing the clearly.

## Mass Spectrometry (Fragmentation Analysis)

Fluorinated esters exhibit distinct fragmentation patterns useful for confirmation.[\[1\]](#)

- Method: GC-MS (EI, 70 eV) or LC-MS (ESI).[\[1\]](#)

- Class A (

-F): Look for the "McLafferty+1" equivalent or

-cleavage.[\[1\]](#) A characteristic loss of

(

) is often observed in the EI source.

- Class B (

-

): The

group is robust.[\[1\]](#) The dominant fragmentation is often the loss of the ester group (

for ethyl esters) followed by loss of

.

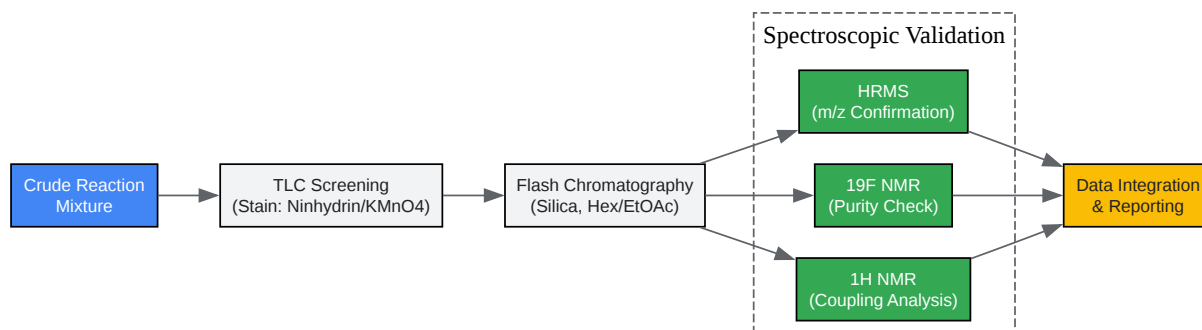

[Click to download full resolution via product page](#)

Figure 2: Standard analytical workflow for isolating and characterizing fluorinated amino esters.

## Stability and Performance Considerations

When selecting between Class A and Class B for drug development:

- Hydrolytic Stability:

- Class A (

-F): The electron-withdrawing fluorine adjacent to the ester makes the carbonyl carbon more electrophilic.[1] These esters hydrolyze faster than their non-fluorinated counterparts under basic conditions.

- Class B (

-

): The steric bulk of the

group provides a "Teflon shield," often retarding hydrolysis despite the electronic activation.

- Racemization Risk:

- -Fluoro esters (Class A) have an acidic  
-proton.<sup>[1][2]</sup> In the presence of strong bases (used during coupling reactions), they are prone to racemization via enolate formation.
- -  
esters (Class B)<sup>[1][2]</sup> lack an acidic proton at the quaternary fluorinated carbon (if fully substituted) or have a less acidic  
-proton (distal to F), making them stereochemically more robust during peptide synthesis.

## References

- Fustero, S., et al. (2002).<sup>[1][3]</sup> "New strategy for the stereoselective synthesis of fluorinated beta-amino acids." Journal of Organic Chemistry. [Link](#)
- Saadi, A., & Wennemers, H. (2016). "Stereoselective Organocatalyzed Synthesis of  
-Fluorinated  
-Amino Thioesters." Angewandte Chemie International Edition. [Link](#)
- BenchChem Technical Guide. (2025). "Spectroscopic Profile of Ethyl 3-amino-4,4,4-trifluorocrotonate." [Link](#)
- PubChem Compound Summary. (2025). "Ethyl 3-amino-3-phenylpropanoate."<sup>[1][2]</sup> National Center for Biotechnology Information.<sup>[1][2]</sup> [Link](#)
- Chemistry Steps. (2024). "NMR Chemical Shift Values Table and Inductive Effects." [Link](#)

### Need Custom Synthesis?

BenchChem offers custom synthesis for rare earth carbides and specific isotopic labeling.

Email: [info@benchchem.com](mailto:info@benchchem.com) or [Request Quote Online](#).

## Sources

- [1. Ethyl 3-amino-3-phenylpropanoate | C11H15NO2 | CID 236379 - PubChem \[pubchem.ncbi.nlm.nih.gov\]](#)
- [2. ethyl 3-amino-3-phenylpropanoate | 6335-76-8 | Buy Now \[molport.com\]](#)
- [3. New strategy for the stereoselective synthesis of fluorinated beta-amino acids - PubMed \[pubmed.ncbi.nlm.nih.gov\]](#)
- [To cite this document: BenchChem. \[Spectroscopic Profiling of Fluorinated -Amino Esters: A Comparative Technical Guide\]. BenchChem, \[2026\]. \[Online PDF\]. Available at: \[https://www.benchchem.com/product/b2926678/docs#spectroscopic-profiling-of-fluorinated-amino-esters-a-comparative-technical-guide\]](#)

---

### Disclaimer & Data Validity:

The information provided in this document is for Research Use Only (RUO) and is strictly not intended for diagnostic or therapeutic procedures. While BenchChem strives to provide accurate protocols, we make no warranties, express or implied, regarding the fitness of this product for every specific experimental setup.

**Technical Support:** The protocols provided are for reference purposes. Unsure if this reagent suits your experiment?

**Need Industrial/Bulk Grade?** [Request Custom Synthesis Quote](#)

## BenchChem

Our mission is to be the trusted global source of essential and advanced chemicals, empowering scientists and researchers to drive progress in science and industry.

### Contact

Address: 3281 E Guasti Rd  
Ontario, CA 91761, United States  
Phone: (601) 213-4426  
Email: [info@benchchem.com](mailto:info@benchchem.com)

Contact our Ph.D. Support Team for a compatibility check