

A Comparative Guide to Alternative Experimental Approaches for TET Enzyme Inhibition

Author: BenchChem Technical Support Team. **Date:** December 2025

Compound of Interest

Compound Name: *Bobcat339 hydrochloride*

Cat. No.: *B2919558*

[Get Quote](#)

For Researchers, Scientists, and Drug Development Professionals

This guide provides a comprehensive comparison of alternative experimental approaches for inhibiting the Ten-eleven translocation (TET) family of enzymes, which are crucial regulators of DNA methylation. Dysregulation of TET enzyme activity is implicated in various diseases, including cancer, making them a significant target for therapeutic intervention. This document outlines direct catalytic inhibition strategies, explores the emerging field of targeted protein degradation, and considers the non-catalytic functions of TET proteins as potential avenues for modulation. Detailed experimental protocols and comparative data are provided to aid researchers in selecting and implementing the most suitable approach for their studies.

Direct Catalytic Inhibition of TET Enzymes

The most common strategy to modulate TET activity is through the use of small molecules that directly inhibit their catalytic function. These inhibitors can be broadly categorized based on their mechanism of action.

Competitive Inhibitors

Competitive inhibitors function by binding to the active site of the TET enzyme, preventing the binding of either the cofactor α -ketoglutarate (α -KG) or the substrate 5-methylcytosine (5mC).

Mutations in the isocitrate dehydrogenase (IDH) and succinate dehydrogenase (SDH) genes can lead to the accumulation of oncometabolites that act as competitive inhibitors of TET enzymes.

- (R)-2-hydroxyglutarate (R-2HG): Produced by mutant IDH1/2 enzymes, R-2HG is structurally similar to α -KG and acts as a competitive inhibitor of TET enzymes.[1][2]
- Succinate and Fumarate: Accumulation of these Krebs cycle intermediates due to mutations in SDH and fumarate hydratase (FH) respectively, can also competitively inhibit TET enzymes.[3][4]

Several small molecules have been developed to competitively inhibit TET enzymes.

- Bobcat339: A cytosine-based inhibitor that has shown selectivity for TET1 and TET2 over the DNA methyltransferase DNMT3a.[5][6][7]
- TETi76: An orally active inhibitor of the TET family.[8][9][10]

Iron Chelators

TET enzymes are iron-dependent dioxygenases, requiring Fe(II) as a critical cofactor for their catalytic activity. Iron chelators can inhibit TET function by sequestering this essential metal ion.

Comparison of TET Enzyme Inhibitors

Inhibitor Class	Inhibitor	Target(s)	IC50 Values	Mechanism of Action	Reference(s)
Oncometabolites	(R)-2-hydroxyglutarate (R-2HG)	TET1, TET2, TET3	TET1: ~0.8 mM TET2: 13-15 μM TET3: ~100 μM	Competitive with α-KG	[1]
Succinate	Tet1, Tet2	~550 μM	Competitive with α-KG	[3][11]	
Fumarate	Tet1, Tet2	~400 μM	Competitive with α-KG	[3][11]	
Small Molecules	Bobcat339	TET1, TET2	TET1: 33 μM TET2: 73 μM	Cytosine-based competitive inhibitor	[6][7]
TETi76	TET1, TET2, TET3	TET1: 1.5 μM TET2: 9.4 μM TET3: 8.8 μM	Competitive inhibitor	[9][10]	

Targeted Protein Degradation: A Future Frontier for TET Inhibition

An emerging alternative to direct enzyme inhibition is the targeted degradation of the entire protein. This can be achieved using technologies like Proteolysis-Targeting Chimeras (PROTACs).

PROTAC Technology Overview

PROTACs are heterobifunctional molecules with two key components: a ligand that binds to the target protein (in this case, a TET enzyme) and a ligand that recruits an E3 ubiquitin ligase.[12] By bringing the TET enzyme and the E3 ligase into close proximity, the PROTAC facilitates the ubiquitination of the TET protein, marking it for degradation by the proteasome.[12] This

approach offers the potential for a more sustained and potent inhibition compared to traditional inhibitors.

To date, the development of PROTACs specifically targeting TET enzymes is a nascent field with no publicly available, well-characterized molecules. However, the principles of PROTAC design offer a promising future direction for TET-targeted therapeutics. The workflow for developing a TET-targeting PROTAC would involve:

- **Ligand Identification:** Identifying high-affinity and selective ligands for the desired TET isoform.
- **Linker Optimization:** Designing and synthesizing a chemical linker of appropriate length and composition to connect the TET ligand to an E3 ligase ligand.
- **E3 Ligase Selection:** Choosing a suitable E3 ligase and its corresponding ligand (e.g., ligands for VHL or Cereblon).
- **Experimental Validation:** Testing the resulting PROTAC for its ability to induce the degradation of the target TET protein in cellular and in vivo models.

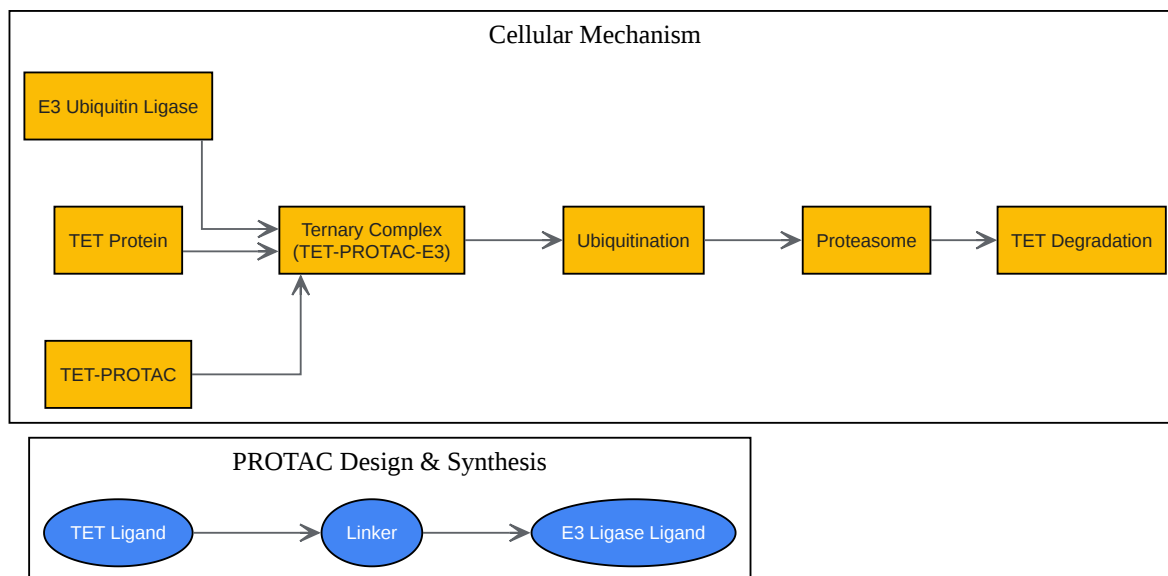

[Click to download full resolution via product page](#)

Conceptual workflow of TET protein degradation via PROTAC technology.

Targeting Non-Catalytic Functions of TET Enzymes

Beyond their catalytic activity, TET proteins also function as scaffolding proteins, interacting with other epigenetic modifiers and transcriptional regulators to influence gene expression.[5][10] This non-catalytic role presents another potential avenue for therapeutic intervention.

TET Protein Interaction Partners

TET proteins have been shown to interact with a variety of other proteins, including:

- O-GlcNAc transferase (OGT): Modulates histone O-GlcNAcylation.[5]
- SIN3A co-repressor complex: Involved in transcriptional repression.[5][10]
- Polycomb Repressive Complex 2 (PRC2): A key regulator of gene silencing.[10]

Disrupting these protein-protein interactions with small molecules or peptides could modulate TET-mediated gene regulation without directly affecting its catalytic activity. This approach could offer a more nuanced way to target specific downstream effects of TET proteins.

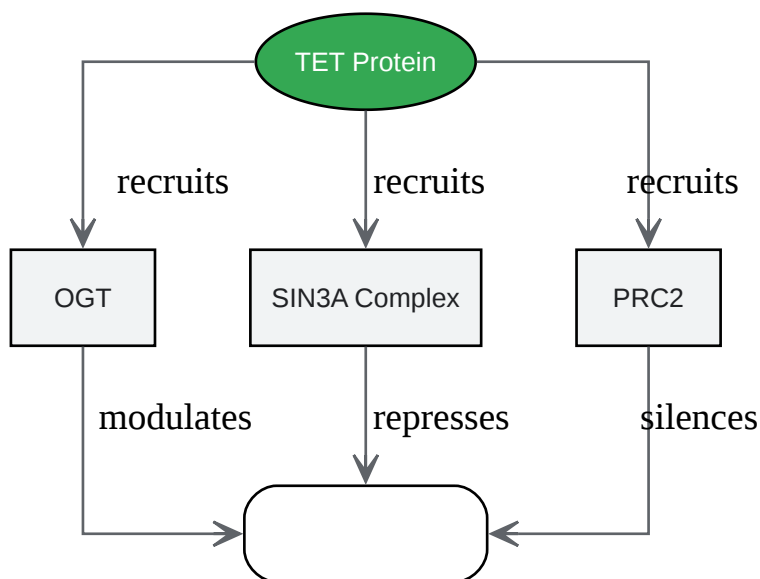

[Click to download full resolution via product page](#)

Need Custom Synthesis?

BenchChem offers custom synthesis for rare earth carbides and specific isotopic labeling.

Email: info@benchchem.com or [Request Quote Online](#).

References

1. researchgate.net [researchgate.net]
2. tandfonline.com [tandfonline.com]
3. Developments of PROTACs technology in immune-related diseases - PubMed [pubmed.ncbi.nlm.nih.gov]
4. PROTAC: An Effective Targeted Protein Degradation Strategy for Cancer Therapy - PubMed [pubmed.ncbi.nlm.nih.gov]

- 5. PROTAC-induced protein structural dynamics in targeted protein degradation - PubMed [pubmed.ncbi.nlm.nih.gov]
- 6. Applications of Covalent Chemistry in Targeted Protein Degradation - PMC [pmc.ncbi.nlm.nih.gov]
- 7. Untitled Document [arxiv.org]
- 8. researchgate.net [researchgate.net]
- 9. Inducing the Degradation of Disease-Related Proteins Using Heterobifunctional Molecules - PMC [pmc.ncbi.nlm.nih.gov]
- 10. PROTACs targeting epigenetic proteins – ScienceOpen [scienceopen.com]
- 11. Recent Advances of Degradation Technologies Based on PROTAC Mechanism - PMC [pmc.ncbi.nlm.nih.gov]
- 12. Frontiers | PROTAC: a revolutionary technology propelling small molecule drugs into the next golden age [frontiersin.org]
- To cite this document: BenchChem. [A Comparative Guide to Alternative Experimental Approaches for TET Enzyme Inhibition]. BenchChem, [2025]. [Online PDF]. Available at: [https://www.benchchem.com/product/b2919558#alternative-experimental-approaches-to-tet-enzyme-inhibition]

Disclaimer & Data Validity:

The information provided in this document is for Research Use Only (RUO) and is strictly not intended for diagnostic or therapeutic procedures. While BenchChem strives to provide accurate protocols, we make no warranties, express or implied, regarding the fitness of this product for every specific experimental setup.

Technical Support: The protocols provided are for reference purposes. Unsure if this reagent suits your experiment? [[Contact our Ph.D. Support Team for a compatibility check](#)]

Need Industrial/Bulk Grade? [Request Custom Synthesis Quote](#)

BenchChem

Our mission is to be the trusted global source of essential and advanced chemicals, empowering scientists and researchers to drive progress in science and industry.

Contact

Address: 3281 E Guasti Rd

Ontario, CA 91761, United States

Phone: (601) 213-4426

Email: info@benchchem.com