

Technical Support Center: Chemoselective Control of Bromo- vs. Chloro-Substituents

Author: BenchChem Technical Support Team. **Date:** April 2026

Compound of Interest

Compound Name: 4-Bromo-1-chloro-2-ethenylbenzene

CAS No.: 1691087-90-7

Cat. No.: B2914401

[Get Quote](#)

Current Status: Operational Subject: Troubleshooting & Optimization Guide for Halogen Selectivity Audience: Synthetic Chemists, Process Chemists, Medicinal Chemists

Core Directive: The Reactivity Hierarchy

The fundamental challenge in differentiating between bromo- and chloro-substituents lies in their bond dissociation energies (BDE). To achieve selectivity, your experimental design must exploit the kinetic window between these two values.

Bond Type	Approx.[1][2][3][4][5] BDE (kcal/mol)	Relative Reactivity (Pd-Catalysis)	Relative Reactivity (Li-Exchange)
C(sp ²)-Br	~81	High (Fast Oxidative Addition)	High (Fast Exchange at -78 °C)
C(sp ²)-Cl	~96	Low (Slow/No Oxidative Addition)	Low (Inert < -40 °C)

The Golden Rule: In 95% of cases, you react the Bromide first. Reacting a Chloride in the presence of a Bromide requires protecting the Bromide (e.g., via silylation) or highly specific, directing-group-controlled Ni-catalysis. This guide focuses on the primary workflow: Selective functionalization of Br while preserving Cl.

Module A: Palladium-Catalyzed Cross-Coupling (Suzuki/Buchwald)[6]

The Mechanism of Selectivity

Selectivity is determined during the Oxidative Addition step. Palladium(0) inserts into the C–Br bond significantly faster than the C–Cl bond. However, "hot" catalytic systems designed to activate aryl chlorides will erode this selectivity, leading to mixtures or double-addition products.

Critical Parameter: Ligand Selection

To preserve a Chloride substituent, you must use a ligand that is active enough to insert into C–Br but too sterically hindered or electron-poor to insert into C–Cl.

Ligand Selection Matrix

Desired Outcome	Recommended Ligands	Catalyst Precursors	Notes
High Selectivity (React Br, Keep Cl)	PPh ₃ , dppf, DPEphos	Pd(PPh ₃) ₄ , Pd(OAc) ₂ , PdCl ₂ (dppf)	These "First Generation" ligands struggle to activate C–Cl bonds, making them perfect for selectivity.
Moderate Risk (Optimization needed)	PCy ₃ , BINAP	Pd ₂ (dba) ₃	Can activate Cl at high temps (>80°C). Keep reaction cool.
Low Selectivity (Risk of Cl reaction)	XPhos, SPhos, P(t-Bu) ₃	Pd-G3/G4 precatalysts	These electron-rich, bulky ligands are designed to activate Chlorides. Avoid if preserving Cl is critical.

Experimental Protocol: Selective Suzuki Coupling

Objective: Couple a boronic acid to the Br-site of 1-bromo-4-chlorobenzene without touching the Cl-site.

- System Prep: Flame-dry a Schlenk flask/vial. Backfill with Argon ().
- Reagents:
 - Substrate: 1.0 equiv (e.g., 1-bromo-4-chlorobenzene).
 - Boronic Acid: 1.1 equiv.
 - Catalyst: 1-3 mol% Pd(PPh₃)₄ (Tetrakis). Why? It is chemically incompetent at activating Ar-Cl under mild conditions.

- Base: 2.0 equiv

(mild) or

. Avoid strong alkoxides (

) if possible.
- Solvent: DME/Water (3:1) or Toluene/Water.[6]
- Execution:
 - Degas solvents (sparge with Ar for 15 min).
 - Heat to 60–80 °C. Do not reflux aggressively (100°C+) unless monitoring confirms Cl stability.
 - Monitor by HPLC/UPLC. Look for the mono-coupled product.
- Troubleshooting: If Cl begins to react, switch solvent to pure Toluene (anhydrous) and use anhydrous

to reduce the rate of transmetallation/turnover, or lower temp to 50 °C.

Workflow Visualization

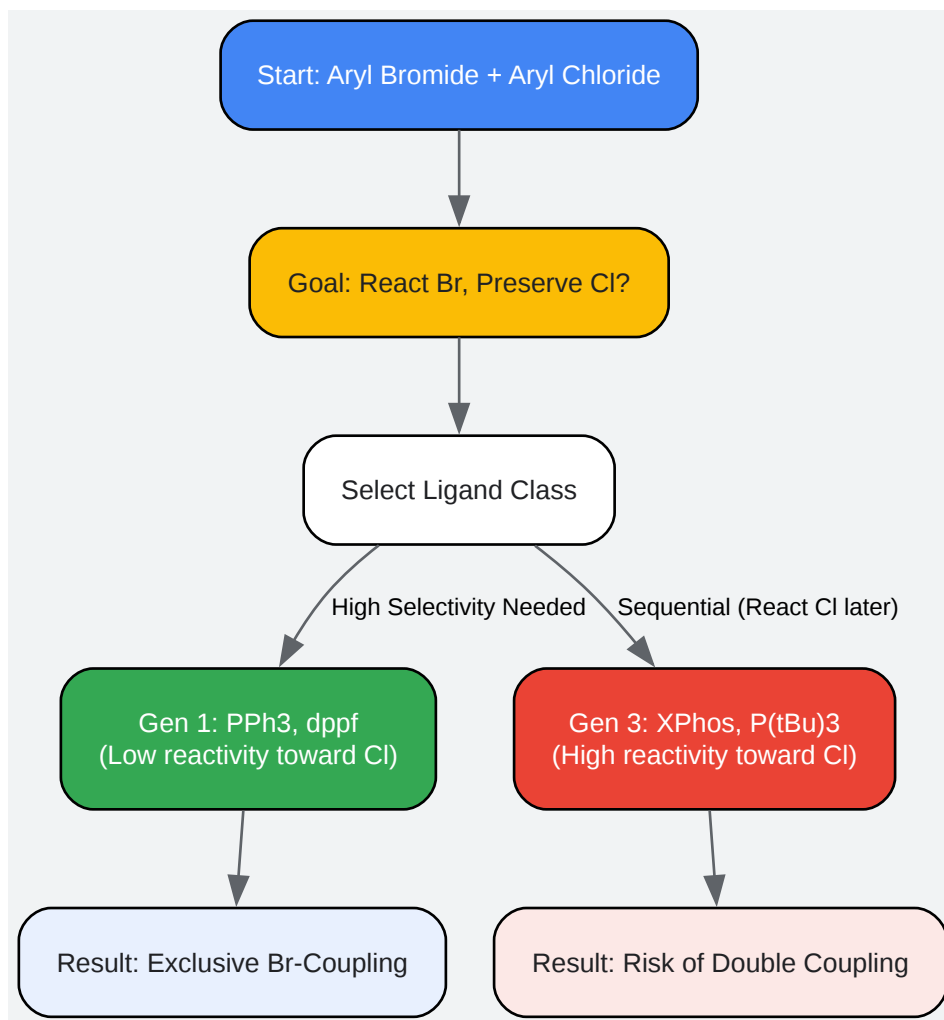

[Click to download full resolution via product page](#)

Caption: Decision tree for ligand selection based on chemoselectivity requirements.

Module B: Metallation (Lithium/Magnesium Exchange)

This is the most dangerous method for selectivity due to "Halogen Scrambling."

The Problem: Scrambling

When you treat Ar-Br-Cl with n-BuLi, you form Ar-Li-Cl. If the reaction warms up (even to -40°C), the highly reactive Ar-Li can attack the Ar-Cl of a neighboring molecule (intermolecular) or eliminate LiCl to form a benzyne (intramolecular).

The Solution: The "Turbo Grignard"

Knochel's Turbo Grignard (

) is the gold standard for this separation.[7]

- Mechanism: The complexation with LiCl breaks polymeric Mg aggregates, making the reagent reactive enough to exchange Br, but the resulting Grignard (

) is less nucleophilic than a Lithium species (

), preventing attack on the Cl moiety.

Comparative Protocol: n-BuLi vs. Turbo Grignard

Feature	Method A: n-Butyllithium	Method B: Turbo Grignard ()
Exchange Temp	Must be -78 °C (Strict).	-15 °C to 0 °C (Flexible).
Cl Tolerance	Poor.[8] Risk of benzyne formation.	Excellent. Cl is inert to Mg at 0°C.
Functional Groups	Intolerant of esters/nitriles.	Tolerates esters/nitriles at low temp.
Recommendation	Use only if Turbo Grignard fails.	Primary Recommendation.

Detailed Protocol: Turbo Grignard Exchange[3]

- Setup: Flame-dried flask, Ar atmosphere.
- Dissolution: Dissolve 1-bromo-3-chlorobenzene (1.0 equiv) in anhydrous THF.
- Exchange:
 - Cool to -15 °C.
 - Add

(1.1 equiv) dropwise.

- Stir for 30 min to 2 hours. Monitor conversion by GC-MS (quench aliquot with water -> look for de-brominated product).
- Trapping:
 - Once exchange is complete (Ar-Br
Ar-Mg), add your electrophile (e.g., aldehyde, amide).
 - Warm to RT slowly.
- Result: Functionalization at Br position; Cl remains intact.

Pathway Visualization

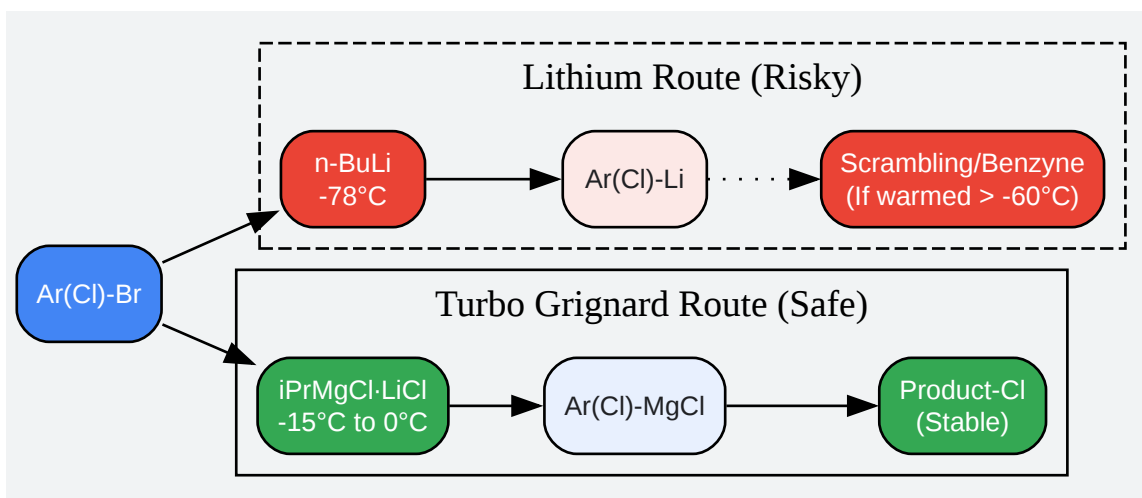

[Click to download full resolution via product page](#)

Caption: Comparison of stability windows between Lithium and Magnesium exchange pathways.

Troubleshooting & FAQs

Q1: I am using Pd(PPh₃)₄, but I am still seeing ~10% reaction at the Chloride. How do I stop this?

Diagnosis: Your reaction temperature is likely too high, or your reaction time is too long. Fix:

- Lower Temperature: Drop from 80°C to 50-60°C.
- Reduce Catalyst Loading: High Pd concentrations increase the probability of the difficult C-Cl insertion. Drop to 0.5 - 1.0 mol%.
- Check Boronic Acid: If your boronic acid is electron-poor (unreactive), the catalyst sits idle, increasing the chance of side reactions. Add the catalyst slowly or use a more reactive boronate species (e.g., trifluoroborate salts).

Q2: Can I react the Chloride before the Bromide?

Short Answer: Generally, no. Detailed Answer: This requires "Selectivity Inversion." It is chemically difficult because C-Br is thermodynamically weaker.

- Workaround 1 (Silylation): Perform Li-Halogen exchange on the Br, trap with TMS-Cl. Now you have Ar(Cl)-TMS. Perform your cross-coupling on the Cl (requires bulky ligands like XPhos). Finally, deprotect the TMS (using ICl or NBS) to regenerate the Bromide.
- Workaround 2 (Ni-Catalysis): Some specific Nickel/NHC catalysts can favor C-Cl activation if a directing group is present near the Cl, but this is substrate-specific and not a general method.

Q3: During Lithium exchange, I see "double addition" or dimerization.

Diagnosis: This is "Halogen Dance" or scrambling. The generated Ar-Li is reacting with the starting material Ar-Br or Ar-Cl.^[9] Fix:

- Barbier Conditions (Internal Quench): Do not pre-form the lithiated species. Mix your substrate and your electrophile (if compatible, like TMSCl or Borates) together, then add n-BuLi. The Li-exchange happens and immediately traps the electrophile before it can attack another molecule.
- Switch to Turbo Grignard: As detailed in Module B, Magnesium species are less prone to this scrambling.

References

- Miyaura, N.; Suzuki, A. "Palladium-Catalyzed Cross-Coupling Reactions of Organoboron Compounds." *Chem. Rev.*[1]1995, 95, 2457–2483.[1] [Link](#)
- Krasovskiy, A.; Knochel, P. "A LiCl-Mediated Br/Mg Exchange Reaction for the Preparation of Functionalized Aryl- and Heteroaryl Magnesium Compounds from Organic Bromides." *Angew. Chem. Int. Ed.*2004, 43, 3333–3336. [Link](#)
- Littke, A. F.; Fu, G. C. "Palladium-Catalyzed Coupling Reactions of Aryl Chlorides." [1] *Angew. Chem. Int. Ed.*2002, 41, 4176–4211. [Link](#)
- Bao, M. et al. "Chemoselective Suzuki Coupling of Dibromoarenes." *J. Org. Chem.*[3]2021. (General reference for ligand effects on selectivity).

Technical Support Case #8842-X Closed. For further assistance, consult the specific kinetic data for your substrate class.

Need Custom Synthesis?

BenchChem offers custom synthesis for rare earth carbides and specific isotopic labeling.

Email: info@benchchem.com or [Request Quote Online](#).

Sources

- 1. macmillan.princeton.edu [macmillan.princeton.edu]
- 2. researchgate.net [researchgate.net]
- 3. researchgate.net [researchgate.net]
- 4. Sequential and iterative Pd-catalyzed cross-coupling reactions in organic synthesis - PMC [pmc.ncbi.nlm.nih.gov]
- 5. joss.tcnj.edu [joss.tcnj.edu]
- 6. Yoneda Labs [yonedalabs.com]
- 7. pubs.rsc.org [pubs.rsc.org]
- 8. Sciencemadness Discussion Board - Aromatic halogen exchange: chloro to bromo - Powered by XMB 1.9.11 [sciencemadness.org]
- 9. Metal–halogen exchange - Wikipedia [en.wikipedia.org]

- To cite this document: BenchChem. [Technical Support Center: Chemoselective Control of Bromo- vs. Chloro-Substituents]. BenchChem, [2026]. [Online PDF]. Available at: [<https://www.benchchem.com/product/b2914401/docs#technical-support-center-chemoselective-control-of-bromo-vs-chloro-substituents>]

Disclaimer & Data Validity:

The information provided in this document is for Research Use Only (RUO) and is strictly not intended for diagnostic or therapeutic procedures. While BenchChem strives to provide accurate protocols, we make no warranties, express or implied, regarding the fitness of this product for every specific experimental setup.

Technical Support: The protocols provided are for reference purposes. Unsure if this reagent suits your experiment?

Need Industrial/Bulk Grade? [Request Custom Synthesis Quote](#)

BenchChem

Our mission is to be the trusted global source of essential and advanced chemicals, empowering scientists and researchers to drive progress in science and industry.

Contact

Address: 3281 E Guasti Rd
Ontario, CA 91761, United States
Phone: (601) 213-4426
Email: info@benchchem.com

[Contact our Ph.D. Support Team for a compatibility check](#)