

Application Note: Regioselective Nitration of 7-methoxy-1H-indole

Author: BenchChem Technical Support Team. **Date:** May 2026

Compound of Interest

Compound Name: 5-Methoxy-6-nitro-1H-indole

CAS No.: 175913-29-8

Cat. No.: B2914146

[Get Quote](#)

Introduction: The Significance of Nitrated Indoles and the Challenge of Regioselectivity

Indole and its derivatives are foundational scaffolds in a vast array of pharmaceuticals and biologically active compounds. The introduction of a nitro group onto the indole ring is a critical transformation, as the nitro group can serve as a versatile handle for further functionalization or as a key pharmacophore in its own right. Specifically, 7-methoxy-nitroindoles are valuable building blocks in medicinal chemistry.

However, the direct nitration of the indole nucleus is notoriously challenging. The high electron density of the pyrrole ring makes it highly susceptible to electrophilic attack, but also prone to oxidation and acid-catalyzed polymerization under harsh nitrating conditions.[1][2]

Regioselectivity is a primary hurdle; the C-3 position is the most nucleophilic, leading to preferential substitution there under non-acidic conditions.[2] Under strongly acidic conditions, protonation at C-3 can deactivate the pyrrole ring, shifting nitration to the benzene ring, typically favoring the C-5 position.[2]

This guide provides a detailed protocol for the regioselective nitration of 7-methoxy-1H-indole, focusing on the synthesis of 7-methoxy-5-nitro-1H-indole. The methoxy group at the C-7 position acts as an ortho-, para-directing group, which, combined with the electronic properties of the indole ring, preferentially directs the incoming electrophile to the C-5 position.[3][4] We will explore the mechanistic rationale, provide a step-by-step experimental procedure, and discuss key considerations for achieving high yield and purity.

Mechanistic Rationale and Regioselectivity

The nitration of 7-methoxy-1H-indole is an electrophilic aromatic substitution reaction. The nitronium ion (NO_2^+), the active electrophile, is typically generated in situ from a mixture of concentrated nitric acid and a stronger acid, such as sulfuric acid.

The regiochemical outcome is governed by the combined directing effects of the indole's fused ring system and the methoxy substituent. The C-7 methoxy group is an activating, ortho-, para-directing group. Potential sites for nitration on the benzene ring are therefore C-4 and C-6. However, the inherent reactivity of the indole ring system also plays a crucial role, favoring substitution at C-5. The electronic and steric environment of the 7-methoxy-1H-indole molecule ultimately favors nitration at the C-5 position.[3]

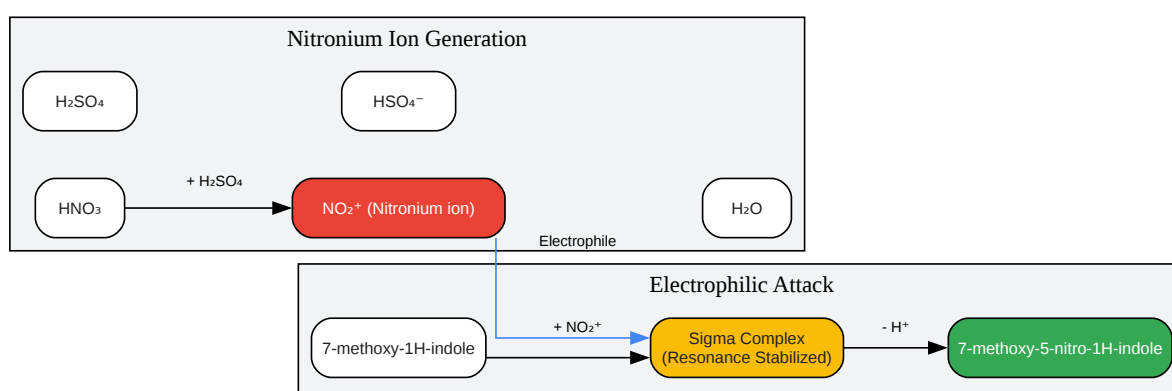

[Click to download full resolution via product page](#)

Caption: General mechanism for the nitration of 7-methoxy-1H-indole.

Experimental Protocol: Synthesis of 7-methoxy-5-nitro-1H-indole

This protocol is a representative procedure adapted from established methods for the nitration of activated aromatic compounds and indole derivatives.[3][4][5] Careful control of temperature is critical to minimize side reactions.

Materials and Reagents

Reagent	Molar Mass (g/mol)	Quantity	Moles (mmol)	Equiv.
7-methoxy-1H-indole	147.17	1.0 g	6.80	1.0
Acetic Acid (Glacial)	60.05	20 mL	-	-
Nitric Acid (fuming, 90%)	63.01	0.48 mL	7.48	1.1
Sulfuric Acid (conc.)	98.08	0.74 mL	13.6	2.0
Dichloromethane (DCM)	84.93	As needed	-	-
Saturated NaHCO ₃ solution	-	As needed	-	-
Brine	-	As needed	-	-
Anhydrous Na ₂ SO ₄ or MgSO ₄	-	As needed	-	-
Ethanol or Methanol	-	For recrystallization	-	-

Procedure

- **Dissolution:** In a 100 mL round-bottom flask equipped with a magnetic stirrer and a dropping funnel, dissolve 7-methoxy-1H-indole (1.0 g, 6.80 mmol) in glacial acetic acid (20 mL).[3][4] Cool the solution to 0-5 °C using an ice-water bath.
- **Preparation of Nitrating Mixture:** In a separate, clean and dry flask, cautiously add concentrated sulfuric acid (0.74 mL) to fuming nitric acid (0.48 mL) at 0 °C. Caution: This mixture is highly corrosive and the addition is exothermic. Prepare this mixture immediately before use and keep it cold.
- **Addition of Nitrating Agent:** Add the cold nitrating mixture dropwise to the stirred solution of 7-methoxy-1H-indole over a period of 20-30 minutes.[3] It is crucial to maintain the internal reaction temperature below 5 °C to prevent over-nitration and the formation of polymeric byproducts.[3][5]
- **Reaction Monitoring:** After the addition is complete, allow the reaction to stir at 0-5 °C. Monitor the progress of the reaction by Thin-Layer Chromatography (TLC) using a suitable eluent system (e.g., Ethyl Acetate/Hexane 1:2). The reaction is typically complete within 2-3 hours, indicated by the consumption of the starting material.[4]
- **Quenching:** Once the reaction is complete, carefully pour the reaction mixture onto crushed ice (approx. 100 g) in a beaker with vigorous stirring.[3][4] This will precipitate the crude product.
- **Work-up and Isolation:**
 - Collect the precipitated solid by vacuum filtration.[3]
 - Wash the solid thoroughly with cold water until the washings are neutral (check with pH paper).
 - If the product does not precipitate fully, the aqueous mixture can be neutralized with a saturated sodium bicarbonate (NaHCO_3) solution and then extracted with an organic solvent like ethyl acetate or dichloromethane.[4]

- Combine the organic layers, wash with brine, dry over anhydrous sodium sulfate (Na_2SO_4), and evaporate the solvent under reduced pressure.[4]
- Purification: The crude 7-methoxy-5-nitro-1H-indole can be purified by one of the following methods:
 - Recrystallization: Recrystallize the crude solid from a suitable solvent such as ethanol or methanol to obtain the purified product as a crystalline solid.[3]
 - Column Chromatography: If recrystallization is insufficient, purify the crude product by column chromatography on silica gel, using an appropriate solvent gradient (e.g., a gradient of ethyl acetate in hexane).[3][4]

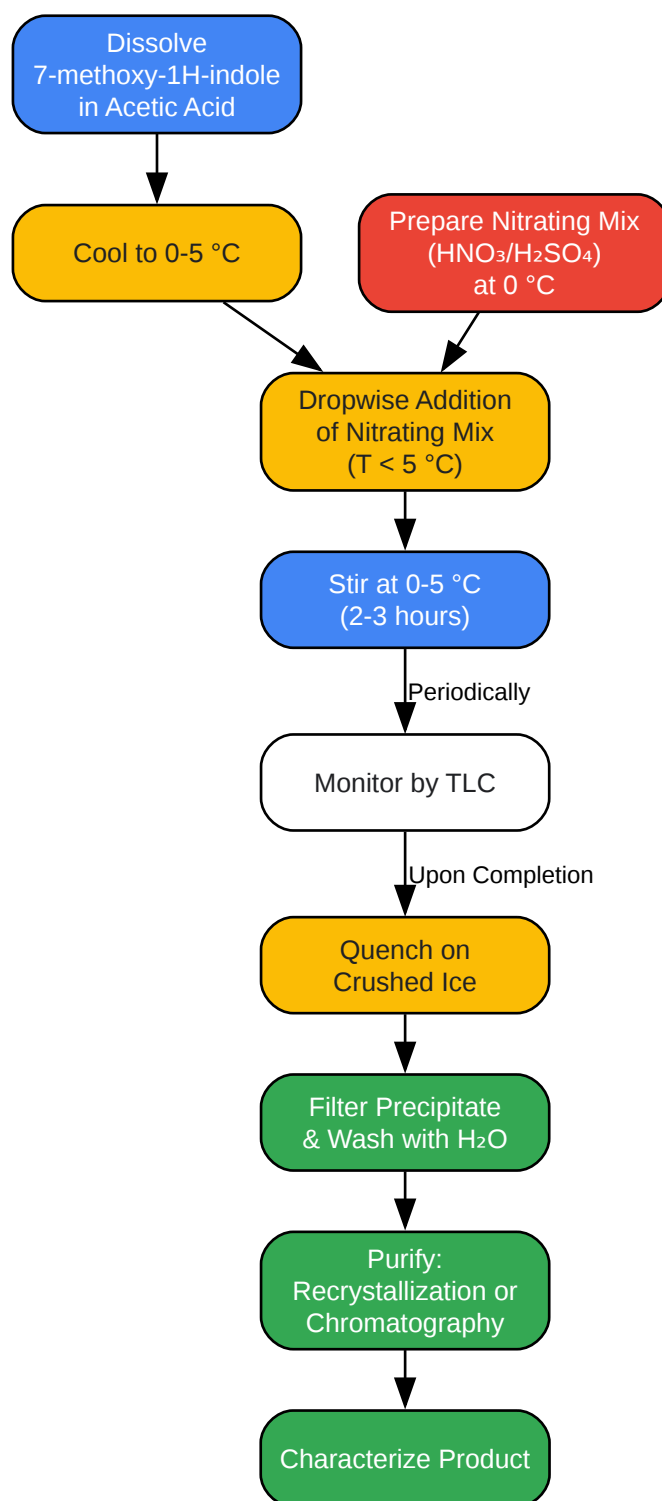

[Click to download full resolution via product page](#)

Caption: Experimental workflow for the synthesis of 7-methoxy-5-nitro-1H-indole.

Troubleshooting and Key Considerations

Issue	Potential Cause(s)	Recommended Solution(s)
Low or No Yield	<ul style="list-style-type: none">- Incomplete reaction.- Acid-catalyzed polymerization.[2]- Loss of product during work-up.	<ul style="list-style-type: none">- Ensure complete consumption of starting material via TLC before quenching.- Strictly maintain the reaction temperature below 5 °C. Avoid strong, non-mixed acids.- If the product is water-soluble, perform an extraction instead of relying solely on precipitation.
Formation of Multiple Isomers	<ul style="list-style-type: none">- Incorrect reaction conditions leading to loss of regioselectivity.- Temperature too high.	<ul style="list-style-type: none">- The C-5 position is electronically and sterically favored. Significant deviation suggests issues with temperature control. Ensure slow, dropwise addition of the nitrating agent.[3]
Formation of Dark, Tarry Byproducts	<ul style="list-style-type: none">- Polymerization of the indole nucleus.[2]- Over-nitration or oxidation.	<ul style="list-style-type: none">- This is a common issue with indole nitration. Maintain low temperatures and use the stoichiometric amount of the nitrating agent.[6] Quench the reaction as soon as the starting material is consumed.
Product is Difficult to Purify	<ul style="list-style-type: none">- Presence of multiple isomers or tarry impurities.	<ul style="list-style-type: none">- Column chromatography is recommended for separating closely related isomers.[4] A pre-column filtration through a short plug of silica may help remove baseline tar.

Conclusion

The regioselective nitration of 7-methoxy-1H-indole to afford the 5-nitro derivative is a feasible transformation, provided that critical reaction parameters, especially temperature, are strictly controlled. The protocol described herein provides a robust starting point for researchers. The resulting 7-methoxy-5-nitro-1H-indole is a valuable intermediate for the synthesis of more complex molecules in drug discovery and materials science. Careful monitoring and purification are key to obtaining the desired product in high purity.

References

- Synthesis of nitroindole derivatives with high affinity and selectivity for melatoninerbic binding sites MT(3). PubMed, National Library of Medicine. [[Link](#)]
- Chemo- and regioselective aqueous phase, co-acid free nitration of aromatics using traditional and nontraditional activation methods. PMC, National Library of Medicine. [[Link](#)]

Need Custom Synthesis?

BenchChem offers custom synthesis for rare earth carbides and specific isotopic labeling.

Email: info@benchchem.com or [Request Quote Online](#).

Sources

- [1. pdf.benchchem.com \[pdf.benchchem.com\]](#)
- [2. pdf.benchchem.com \[pdf.benchchem.com\]](#)
- [3. pdf.benchchem.com \[pdf.benchchem.com\]](#)
- [4. pdf.benchchem.com \[pdf.benchchem.com\]](#)
- [5. pdf.benchchem.com \[pdf.benchchem.com\]](#)
- [6. pdf.benchchem.com \[pdf.benchchem.com\]](#)
- To cite this document: BenchChem. [Application Note: Regioselective Nitration of 7-methoxy-1H-indole]. BenchChem, [2026]. [Online PDF]. Available at: [<https://www.benchchem.com/product/b2914146/docs#application-note-regioselective-nitration-of-7-methoxy-1h-indole>]

Disclaimer & Data Validity:

The information provided in this document is for Research Use Only (RUO) and is strictly not intended for diagnostic or therapeutic procedures. While BenchChem strives to provide accurate protocols, we make no warranties, express or implied, regarding the fitness of this product for every specific experimental setup.

Technical Support: The protocols provided are for reference purposes. Unsure if this reagent suits your experiment?

Need Industrial/Bulk Grade? [Request Custom Synthesis Quote](#)

BenchChem

Our mission is to be the trusted global source of essential and advanced chemicals, empowering scientists and researchers to drive progress in science and industry.

Contact

Address: 3281 E Guasti Rd
Ontario, CA 91761, United States
Phone: (601) 213-4426
Email: info@benchchem.com

[Contact our Ph.D. Support Team for a compatibility check](#)