

Technical Support Guide: Grignard Formation with Electron-Deficient Fluorinated Arenes

Author: BenchChem Technical Support Team. **Date:** April 2026

Compound of Interest

Compound Name: *1-Bromo-2-(2,2,3,3-tetrafluorocyclobutyl)benzene*

CAS No.: *2138062-05-0*

Cat. No.: *B2913038*

[Get Quote](#)

Safety Warning: High Hazard Class

STOP. Before proceeding, acknowledge that fluorinated aryl Grignard reagents pose unique thermal hazards.[1] Unlike standard phenyl Grignards, perfluorinated analogs (e.g., pentafluorophenylmagnesium bromide) are prone to explosive decomposition via benzyne formation if temperature thresholds are exceeded. Ensure a Class D fire extinguisher and blast shield are present.

The Core Challenge: The "Reactivity Paradox"

Users often report two contradictory failures when working with electron-deficient fluorinated arenes (e.g., pentafluorobromobenzene, difluorobromobenzene):

- **Initiation Failure:** The reaction won't start because the electron-deficient ring renders the C-Br bond less nucleophilic toward the magnesium surface, and the C-F bonds passivate the metal.

- Runaway/Decomposition: Once formed, the Grignard reagent is thermally unstable.^[1] The fluorine atoms ortho to the magnesium make the molecule susceptible to

-elimination (forming benzyne), leading to "tars" or rapid over-pressurization.

Quick Diagnostic: Which Method Should You Use?

Feature	Method A: Direct Insertion (Traditional)	Method B: Mg-Halogen Exchange (Recommended)
Reagent	Mg Turnings / Powder	iPrMgCl ^[1] ·LiCl (Turbo Grignard)
Temperature	Reflux often required to start; dangerous.	-20°C to 0°C (Controlled).
Safety Profile	High Risk (Induction periods, Exotherms). ^{[1][2]}	High Safety (Homogeneous, predictable). ^[1]
Functional Group Tolerance	Low (Esters/Nitriles attacked). ^[1]	High (Kinetic control protects sensitive groups).
Success Rate with F-Arenes	Low to Moderate.	>95%

Phase 1: The Solution (Magnesium-Halogen Exchange)

Recommendation: Unless you have a specific process constraint, abandon direct insertion. Use the Knochel Turbo Grignard exchange method. It decouples the formation of the reagent from the activation of the metal.

Protocol: Turbo Grignard Exchange

Target: Conversion of Bromopentafluorobenzene to Pentafluorophenylmagnesium Chloride.^[1]

- Preparation: Flame-dry a Schlenk flask under Argon.
- Charging: Add the fluorinated aryl bromide (1.0 equiv) and anhydrous THF (concentration ~0.5 – 1.0 M).

- Cooling: Cool the solution to -20°C .
 - Note: While exchange can occur at RT, lower temperatures prevent benzyne elimination. [1]
- Exchange: Dropwise add $\text{iPrMgCl}[1]\cdot\text{LiCl}$ (1.3 M in THF, 1.1 equiv) over 10 minutes.
- Monitoring: Stir at -20°C for 30–60 minutes.
 - QC Check: Pull a 0.1 mL aliquot, quench with iodine, and check GC/LCMS. Disappearance of Ar-Br and appearance of Ar-I confirms Grignard formation. [1]

Why This Works (The Mechanism)

The Lithium Chloride additive breaks up the polymeric aggregates of the Grignard reagent, creating a highly reactive monomeric "ate" complex. This lowers the activation energy for the exchange, allowing it to happen at temperatures where the fluorinated Grignard is stable.

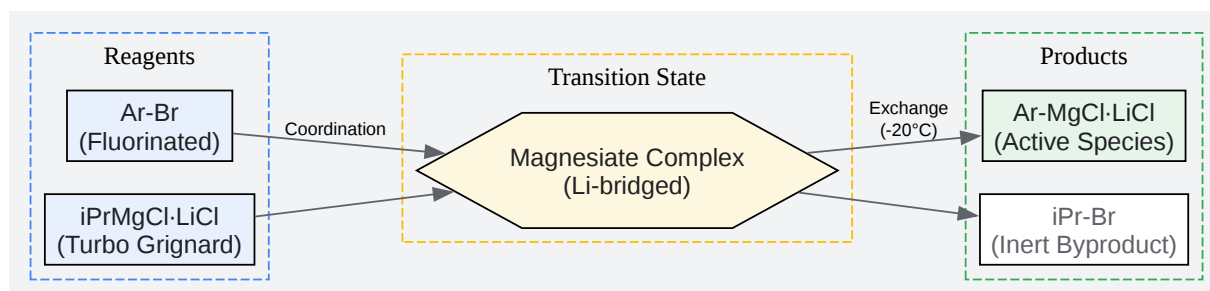

[Click to download full resolution via product page](#)

Caption: The LiCl additive accelerates the exchange via a magnesiate intermediate, allowing formation at safe temperatures.

Phase 2: Troubleshooting Direct Insertion (If Mandatory)

If you must use Mg metal (e.g., cost constraints on large scale), follow this troubleshooting guide.

Common Failure: "The Reaction Won't Start"

Cause: Fluorinated arenes do not coordinate well to the Mg surface, and the MgO passivation layer is stubborn.

Corrective Actions:

- Mechanical Activation: Do not use turnings. Use Mg Powder (approx. 50 mesh) or Rieke Magnesium (freshly prepared).[1]
- Chemical Activation (The DIBAL-H Method):
 - Add Mg and THF.[3][4]
 - Add 1-2 mol% DIBAL-H.
 - Stir 10 mins. The hydride strips the oxide layer and acts as a soluble reductant to initiate the radical transfer.
- The Entrainment Method:
 - Add 5% of the total Mg and 5% of the halide.
 - Add 1,2-dibromoethane (0.1 equiv).[1]
 - Wait for ethylene evolution (bubbles). Once active, trickle feed the fluorinated halide.

Visual Troubleshooting Tree

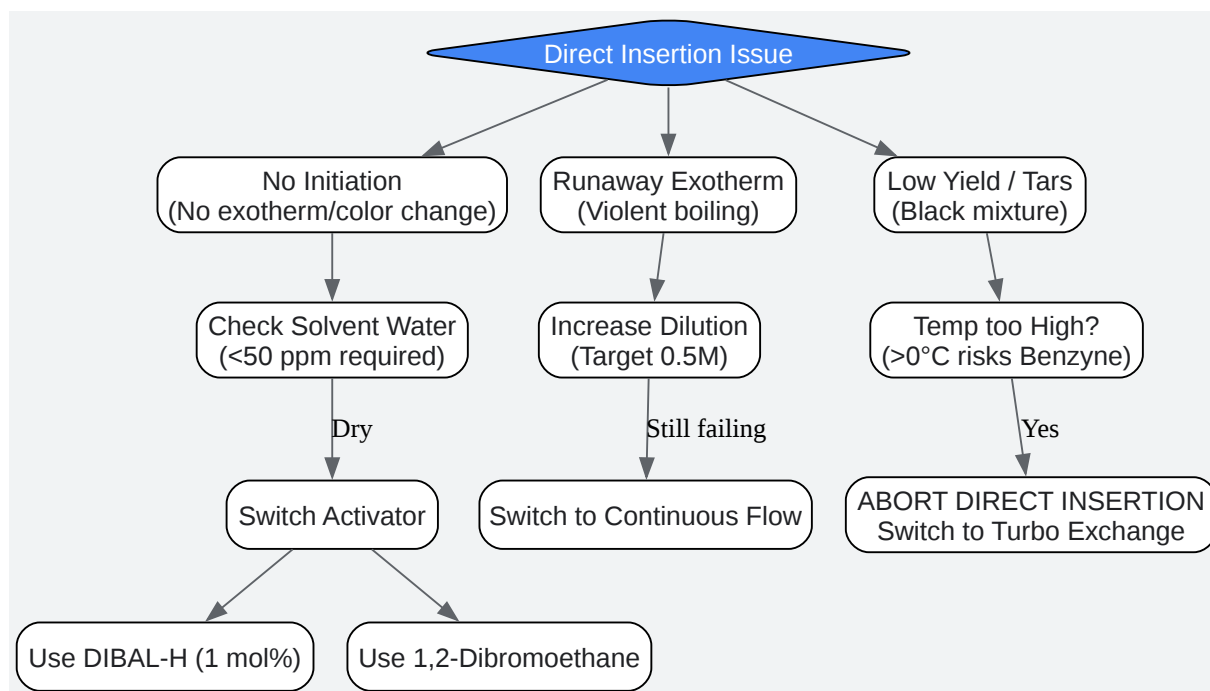

[Click to download full resolution via product page](#)

Caption: Decision logic for diagnosing initiation failures and stability issues in direct Grignard synthesis.

Critical Failure Mode: The "Benzyne" Explosion Risk

The Issue: Fluorinated Grignards are inherently unstable.[1] Mechanism: The Magnesium atom is electron-rich.[1] The ortho-fluorine is highly electronegative.[1] If the system has enough thermal energy, MgFBr eliminates, generating a tetrafluorobenzyne. Result: Benzyne is extremely reactive electrophile.[1] They instantly react with:

- Solvent (THF polymerization).
- Grignard reagent (Coupling).[3][5]

- Themselves (Explosive polymerization).

Safety Limit: Never reflux a polyfluorinated Grignard. Maintain $T < 0^{\circ}\text{C}$.

Caption: Thermal decomposition pathway of ortho-fluorinated Grignard reagents leading to benzyne formation.^[1]

Analytcs: How to Titrate

You cannot assume theoretical yield. You must titrate before use.

Recommended Protocol: Iodine/LiCl Method Why: Sharp endpoint, works for Turbo Grignards.

- Reagent: Dissolve Iodine (254 mg, 1.0 mmol) in 5 mL of a 0.5 M LiCl/THF solution.
- Process: Add the Grignard solution dropwise to the iodine solution at 0°C .
- Endpoint: The solution transitions from Deep Brown

Pale Yellow

Colorless.

- Calculation:

FAQ: Specific User Scenarios

Q: Can I use Diethyl Ether instead of THF? A: For direct insertion, Ether is safer regarding benzyne formation (lower boiling point), but it is often too non-polar to solubilize the passivated surface intermediates. For Turbo Exchange, THF is mandatory because the LiCl-Mg complex requires THF solvation to function.

Q: My reaction turns black immediately. Is it dead? A: Likely yes.^[1] A black slurry usually indicates Wurtz coupling (Ar-Ar dimerization) or benzyne polymerization.^[1] This happens if the concentration of organic halide is too high relative to the Mg surface area. Solution: Switch to semi-batch addition (slow addition of halide) or use the Turbo Exchange method.

Q: I need to scale this to 1kg. Any advice? A: Do not run this in batch at 1kg scale without reaction calorimetry (RC1) data. The induction period can lead to accumulation of halide,

followed by a massive exotherm that triggers the benzyne decomposition. Strongly consider Continuous Flow Chemistry (CSTR or Packed Bed) to keep the active volume low.

References

- The Turbo Grignard Discovery: Krasovskiy, A., & Knochel, P. (2004).[6] A LiCl-Mediated Br/Mg Exchange Reaction for the Preparation of Functionalized Aryl- and Heteroarylmagnesium Compounds from Organic Bromides.[7][8] *Angewandte Chemie International Edition*, 43(25), 3333–3336. [Link](#)
- Benzyne Mechanism & Safety: Brewer, M., et al. (2018).[1] Safety Assessments of Grignard Reagents: Thermal Stability and Runaway Reactions. *Organic Process Research & Development*, 22(5), 630-638.
- Titration Protocol: Krasovskiy, A., & Knochel, P. (2006). Convenient Titration Method for Organometallic Zinc, Magnesium, and Lanthanide Reagents. *Synthesis*, 2006(05), 890–891. [Link](#)
- Continuous Flow Application: Ganiek, M. A., et al. (2019).[1] Improving the Halogen–Magnesium Exchange by using New Turbo-Grignard Reagents.[1] *Chemistry – A European Journal*, 25(11), 2695-2703. [Link\[1\]](#)
- Activation of Mg: Rieke, R. D., & Bales, S. E. (1974). Activated metals.[5] IV. Preparation and reactions of highly reactive magnesium metal. *Journal of the American Chemical Society*, 96(6), 1775–1781. [Link](#)

Need Custom Synthesis?

BenchChem offers custom synthesis for rare earth carbides and specific isotopic labeling.

Email: info@benchchem.com or [Request Quote Online](#).

Sources

- [1. Pentafluorophenylmagnesium bromide 0.5M diethyl ether 879-05-0 \[sigmaaldrich.com\]](#)
- [2. sumitomo-chem.co.jp \[sumitomo-chem.co.jp\]](#)

- [3. Grignard reagent - Wikipedia \[en.wikipedia.org\]](#)
- [4. chem.libretexts.org \[chem.libretexts.org\]](#)
- [5. chemistry.stackexchange.com \[chemistry.stackexchange.com\]](#)
- [6. portal.tpu.ru \[portal.tpu.ru\]](#)
- [7. A LiCl-Mediated Br/Mg Exchange Reaction for the Preparation of Functionalized Aryl- and Heteroarylmagnesium Compounds from Organic Bromides \[organic-chemistry.org\]](#)
- [8. organic-chemistry.org \[organic-chemistry.org\]](#)
- To cite this document: BenchChem. [Technical Support Guide: Grignard Formation with Electron-Deficient Fluorinated Arenes]. BenchChem, [2026]. [Online PDF]. Available at: [\[https://www.benchchem.com/product/b2913038/docs#technical-support-guide-grignard-formation-with-electron-deficient-fluorinated-arenes\]](https://www.benchchem.com/product/b2913038/docs#technical-support-guide-grignard-formation-with-electron-deficient-fluorinated-arenes)

Disclaimer & Data Validity:

The information provided in this document is for Research Use Only (RUO) and is strictly not intended for diagnostic or therapeutic procedures. While BenchChem strives to provide accurate protocols, we make no warranties, express or implied, regarding the fitness of this product for every specific experimental setup.

Technical Support: The protocols provided are for reference purposes. Unsure if this reagent suits your experiment?

Need Industrial/Bulk Grade? [Request Custom Synthesis Quote](#)

BenchChem

Our mission is to be the trusted global source of essential and advanced chemicals, empowering scientists and researchers to drive progress in science and industry.

Contact

Address: 3281 E Guasti Rd

Ontario, CA 91761, United States

Phone: (601) 213-4426

Email: info@benchchem.com

Contact our Ph.D. Support Team for a compatibility check