

Technical Guide: Reactivity Profiling of cis- vs. trans-1-Bromo-3-methoxycyclohexane

Author: BenchChem Technical Support Team. **Date:** May 2026

Compound of Interest

Compound Name: *1-Bromo-3-methoxycyclohexane*

CAS No.: *1533933-93-5*

Cat. No.: *B2907573*

[Get Quote](#)

Part 1: Executive Technical Summary

In the context of nucleophilic substitution and elimination reactions, **trans-1-bromo-3-methoxycyclohexane** exhibits significantly higher reactivity compared to its cis isomer.

The reactivity differential is governed by the Curtin-Hammett principle and ground-state conformational analysis. The trans isomer possesses a ground-state conformation where the leaving group (Bromide) is axial, satisfying the stereoelectronic requirements for E2 elimination and minimizing steric hindrance for SN2 transition states. Conversely, the cis isomer exists in a stable diequatorial conformation that is kinetically dormant for E2 elimination, requiring a high-energy ring flip to react.

Feature	Trans-Isomer	Cis-Isomer
Ground State Conformation	Anancomeric (OMeeq, Brax)	Anancomeric (OMeeq, Breq)
E2 Elimination Rate	Fast ()	Slow (Requires ring flip)
SN2 Susceptibility	High (Unimpeded equatorial attack)	Low (Sterically hindered axial attack)
Solvolysis (SN1) Rate	Accelerated (Relief of 1,3-diaxial strain)	Baseline (Ground state stabilized)

Part 2: Structural & Conformational Analysis

To predict reactivity, we must first establish the population of reactive conformers. We utilize A-values (free energy difference between axial and equatorial positions) to determine the equilibrium.

- A-value (Br): ~ 0.38 kcal/mol
- A-value (OMe): ~ 0.60 kcal/mol

Cis-1-Bromo-3-methoxycyclohexane

- Stereochemistry: 1,3-disubstituted cis geometry places both groups either (axial, axial) or (equatorial, equatorial).
- Equilibrium: The (e,e) conformer is stabilized by the sum of A-values.
 - kcal/mol (favoring e,e).
- Implication: The bromine is equatorial in the dominant conformer.

Trans-1-Bromo-3-methoxycyclohexane

- Stereochemistry: 1,3-disubstituted trans geometry places one group axial and the other equatorial.

- Equilibrium: The system minimizes energy by placing the larger group (OMe) equatorial.
 - Conformer A: OMeeq / Brax (Stable)
 - Conformer B: OMeax / Breq (Unstable due to higher A-value of OMe)
- Implication: The bromine is axial in the dominant conformer.

Visualization of Conformational Pathways

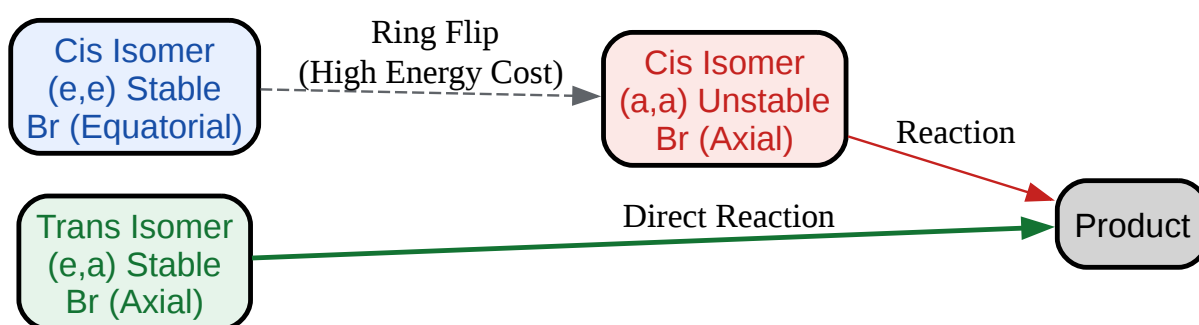

[Click to download full resolution via product page](#)

Figure 1: Conformational landscape showing the kinetic barrier for the cis-isomer.

Part 3: Reactivity Profiles & Mechanism

E2 Elimination (Dehydrohalogenation)

The Core Requirement: E2 elimination requires an anti-periplanar arrangement (180° dihedral angle) between the leaving group (Br) and a

-hydrogen. This is only possible when the Br is axial.

- Trans-Isomer (High Reactivity):
 - The stable conformer has Brax.
 - Axial hydrogens exist at C2 and C6.
 - Outcome: Immediate, concerted elimination occurs with base (e.g., NaOEt). The transition state is low energy because the ground state is already pre-organized.

- Cis-Isomer (Low Reactivity):
 - The stable conformer has Breq. No anti-periplanar hydrogen exists.
 - Mechanism: The molecule must ring-flip to the (a,a) conformer to place Br axial. This places the OMe group axial as well, creating severe 1,3-diaxial steric strain.
 - Outcome: Reaction rate is throttled by the equilibrium constant of the ring flip ().

SN2 Substitution

The Core Requirement: Backside attack by the nucleophile.

- Trans-Isomer (Brax):
 - The nucleophile approaches from the equatorial trajectory.
 - This path is relatively unhindered, avoiding the steric bulk of the ring hydrogens.
 - Result: Faster substitution.
- Cis-Isomer (Breq):
 - The nucleophile must approach from the axial trajectory.
 - This path is sterically encumbered by the axial hydrogens at C3 and C5 (1,3-diaxial repulsion).
 - Result: Slower substitution due to steric blocking of the electrophilic center.

Part 4: Experimental Validation Protocol

Use this self-validating protocol to distinguish the isomers based on reaction kinetics.

Reagents:

- Substrate (100 mg)

- Sodium Ethoxide (NaOEt), 1.0 M in Ethanol
- Internal Standard (e.g., Dodecane)

Methodology:

- Setup: Dissolve substrate and internal standard in dry ethanol (5 mL).
- Initiation: Add NaOEt solution (2 equiv) at 25°C.
- Monitoring: Aliquot every 5 minutes for GC/MS analysis.
- Data Interpretation:
 - Fast consumption (< 15 mins) with formation of 3-methoxycyclohexene indicates the Trans isomer (E2 dominance).
 - Slow consumption (> 2 hours) or appearance of substitution products (ethers) indicates the Cis isomer.

Reaction Pathway Diagram

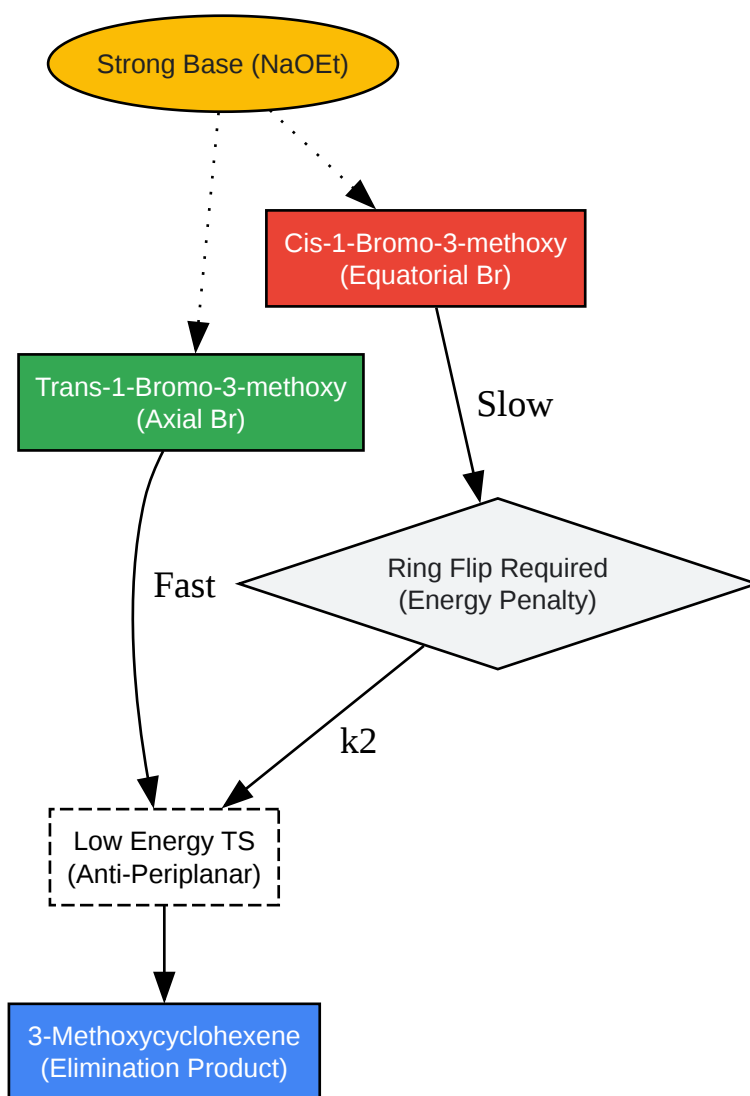

[Click to download full resolution via product page](#)

Figure 2: Kinetic pathway comparison demonstrating the direct route of the trans-isomer vs. the indirect route of the cis-isomer.

References

- Eliel, E. L. (1962). Stereochemistry of Carbon Compounds. McGraw-Hill.
- Winstein, S., & Holness, N. J. (1955). "Neighboring Carbon and Hydrogen.[1][2] XIX. t-Butylcyclohexyl Derivatives. Quantitative Conformational Analysis." Journal of the American Chemical Society.[3] [Link](#)
- Carey, F. A., & Sundberg, R. J. (2007). Advanced Organic Chemistry: Part A: Structure and Mechanisms. Springer.

- Smith, M. B. (2013). March's Advanced Organic Chemistry: Reactions, Mechanisms, and Structure. Wiley. [Link](#)

Need Custom Synthesis?

BenchChem offers custom synthesis for rare earth carbides and specific isotopic labeling.

Email: info@benchchem.com or [Request Quote Online](#).

Sources

- 1. chem.libretexts.org [chem.libretexts.org]
- 2. When 1-Bromo-1-methylcyclohexane is heated in ethanol for an extended period of time, three products result : one ether and two alkenes . Predict the products of this reaction, and propose mechanism for their formation.Also, mention the major elimination product. [[allen.in](#)]
- 3. quora.com [quora.com]
- To cite this document: BenchChem. [Technical Guide: Reactivity Profiling of cis- vs. trans-1-Bromo-3-methoxycyclohexane]. BenchChem, [2026]. [Online PDF]. Available at: [<https://www.benchchem.com/product/b2907573/docs#technical-guide-reactivity-profiling-of-cis-vs-trans-1-bromo-3-methoxycyclohexane>]

Disclaimer & Data Validity:

The information provided in this document is for Research Use Only (RUO) and is strictly not intended for diagnostic or therapeutic procedures. While BenchChem strives to provide accurate protocols, we make no warranties, express or implied, regarding the fitness of this product for every specific experimental setup.

Technical Support: The protocols provided are for reference purposes. Unsure if this reagent suits your experiment?

Need Industrial/Bulk Grade? [Request Custom Synthesis Quote](#)

BenchChem

Our mission is to be the trusted global source of essential and advanced chemicals, empowering scientists and researchers to drive progress in science and industry.

Contact

Address: 3281 E Guasti Rd

Ontario, CA 91761, United States

Phone: (601) 213-4426

Email: info@benchchem.com

[Contact our Ph.D. Support Team for a compatibility check](#)