

Technical Support Center: Optimizing Reaction Temperature for Cyclopropanecarbonyl Chloride Coupling

Author: BenchChem Technical Support Team. **Date:** May 2026

Compound of Interest

Compound Name: *N*-(4-ethylphenyl)cyclopropanecarboxamide

Cat. No.: B290456

[Get Quote](#)

Welcome to the technical support center for optimizing coupling reactions with cyclopropanecarbonyl chloride (CPCC). This guide is designed for researchers, scientists, and drug development professionals to provide in-depth technical guidance and troubleshooting advice. Cyclopropanecarbonyl chloride is a highly valuable reagent, prized for its ability to introduce the compact and metabolically robust cyclopropyl moiety into a wide range of molecules.^{[1][2]} However, its heightened reactivity, a direct consequence of the inherent strain in the three-membered ring, necessitates careful control over reaction parameters, particularly temperature, to ensure high yields and minimize side reactions.^{[1][3]}

This document will provide a comprehensive overview of temperature optimization strategies for two primary classes of CPCC coupling reactions: Amide Bond Formation and Friedel-Crafts Acylation. We will delve into common issues, their underlying causes, and provide actionable troubleshooting protocols.

Part 1: Troubleshooting Guide

This section addresses specific problems you may encounter during your experiments and provides step-by-step guidance to resolve them.

Scenario 1: Amide Coupling - Low Yield of the Desired Amide

Question: I am reacting cyclopropanecarbonyl chloride with my amine of interest, but I am observing a low yield of the final amide product. What are the likely temperature-related causes and how can I fix this?

Answer:

Low yields in amide coupling reactions with CPCC can often be traced back to suboptimal temperature control. The reaction of an acyl chloride with an amine is typically very fast and exothermic.^[4]

Potential Causes & Troubleshooting Steps:

- **Localized Heating and Degradation:** Rapid, uncontrolled addition of CPCC to the amine solution can create localized hot spots, even if the reaction flask is in a cooling bath. This can lead to the degradation of either the starting materials or the product.
 - **Solution:**
 - **Slow, Controlled Addition:** Add the cyclopropanecarbonyl chloride dropwise to a cooled solution of the amine and a suitable base (e.g., triethylamine, pyridine) over an extended period.^[5]
 - **Efficient Stirring:** Ensure vigorous stirring to dissipate heat effectively throughout the reaction mixture.
- **Side Reactions at Elevated Temperatures:** For less reactive or sterically hindered amines, you might be tempted to increase the reaction temperature. However, this can promote side reactions.
 - **Solution:**

- Optimize at Low Temperatures First: Start your optimization at a low temperature, such as 0 °C, and only gradually increase it if the reaction is too slow. Many amide formations with CPCC proceed efficiently at or below room temperature.[5][6] A general starting range is 0 °C to room temperature.[6]
- Use a Catalyst: For challenging couplings, consider adding a catalyst like 4-dimethylaminopyridine (DMAP) to facilitate the reaction at a lower temperature.[4][7]
- Instability of Reactants or Products: Your amine or the resulting amide may be thermally labile.
 - Solution:
 - Review Stability Data: Check the literature for the thermal stability of your specific amine and amide product.
 - Maintain Low Temperatures: If stability is a concern, conduct the entire reaction and workup at low temperatures (e.g., 0-5 °C).

Scenario 2: Friedel-Crafts Acylation - Presence of Ring-Opened Byproducts

Question: I am performing a Friedel-Crafts acylation with cyclopropanecarbonyl chloride and an aromatic substrate, but my analysis shows the presence of a significant byproduct that appears to be a result of the cyclopropane ring opening. How can I prevent this?

Answer:

Ring-opening of the cyclopropyl group is a known side reaction in Friedel-Crafts acylations, especially with activated cyclopropanes.[8][9] This is often promoted by strong Lewis acids and elevated temperatures. The Lewis acid can coordinate to the carbonyl oxygen of the resulting cyclopropyl ketone, which activates the strained ring towards nucleophilic attack or rearrangement.[9]

Potential Causes & Troubleshooting Steps:

- Excessive Reaction Temperature: Higher temperatures provide the activation energy needed to overcome the barrier for ring cleavage.[9]
 - Solution:
 - Low-Temperature Protocol: Conduct the reaction at the lowest temperature that still allows for a reasonable reaction rate. For many Friedel-Crafts reactions, a starting temperature of 0-5 °C is recommended.[8] For highly activated aromatic substrates like anisole, the temperature can be lowered even further to -10 to 0 °C to enhance selectivity.[8]
- Strong Lewis Acid Activity: Potent Lewis acids like aluminum chloride (AlCl_3) can aggressively promote ring-opening.
 - Solution:
 - Use a Milder Lewis Acid: Consider screening milder Lewis acids such as ferric chloride (FeCl_3), zinc chloride (ZnCl_2), or scandium triflate ($\text{Sc}(\text{OTf})_3$).
 - Stoichiometry of Lewis Acid: Use the minimum effective amount of the Lewis acid. A stoichiometric amount is often required, but an excess should be avoided.
- Prolonged Reaction Times at Elevated Temperatures: Even at moderately elevated temperatures, extended reaction times can lead to the accumulation of ring-opened byproducts.
 - Solution:
 - Reaction Monitoring: Closely monitor the reaction progress by TLC or LC-MS. Quench the reaction as soon as the starting material is consumed to a satisfactory level.
 - Optimize for Shorter Reaction Times: If the reaction is slow at low temperatures, it may be preferable to use a slightly more active (but still mild) Lewis acid rather than significantly increasing the temperature or time.

Part 2: Frequently Asked Questions (FAQs)

Q1: What is the ideal starting temperature for a typical amide coupling with cyclopropanecarbonyl chloride?

A1: For most primary and secondary amines, a starting temperature of 0 °C is recommended. The reaction is often exothermic, and starting at a low temperature allows for better control. The reaction can then be allowed to slowly warm to room temperature. For very reactive amines, maintaining the temperature at 0 °C throughout the addition may be necessary. A general range to explore during optimization is -20 °C to 25 °C.[9]

Q2: How does the reactivity of the aromatic substrate affect the optimal temperature in a Friedel-Crafts acylation?

A2: The electron density of the aromatic ring plays a crucial role.

- Electron-Rich Aromatics (e.g., anisole, phenols): These are highly reactive and should be acylated at lower temperatures (-10 °C to 0 °C) to prevent side reactions and control regioselectivity.[8]
- Moderately Activated/Neutral Aromatics (e.g., toluene, benzene): These typically require standard conditions, often starting at 0-5 °C and potentially warming to room temperature.[8]
- Deactivated Aromatics (e.g., nitrobenzene): These are generally poor substrates for Friedel-Crafts acylation and may require higher temperatures, which in turn increases the risk of ring-opening of the cyclopropyl moiety.[8]

Q3: Can cyclopropanecarbonyl chloride itself decompose at higher temperatures?

A3: Cyclopropanecarbonyl chloride is a relatively stable liquid with a boiling point of approximately 119 °C.[10][11][12] However, it is sensitive to moisture and can be heat-sensitive, especially in the presence of impurities.[7][13] For storage, refrigeration at 2-8 °C is recommended to minimize decomposition over time.[10][11] During a reaction, the primary concern at elevated temperatures is not typically the unimolecular decomposition of the acyl chloride itself, but rather its propensity to drive unwanted side reactions.

Q4: What is the Schotten-Baumann reaction and what are the typical temperature conditions?

A4: The Schotten-Baumann reaction is a method for synthesizing amides from amines and acyl chlorides, often using a two-phase system with an aqueous base (like NaOH) and an organic solvent.^{[14][15]} These reactions are typically carried out at room temperature or slightly above.^{[14][15]} Careful temperature control is still important to manage the exothermic nature of the reaction and to minimize the hydrolysis of the acyl chloride, which is a competing side reaction.^[16]

Part 3: Data & Protocols

Recommended Temperature Ranges for CPCC Coupling Reactions

Reaction Type	Substrate Type	Recommended Starting Temperature	Notes
Amide Coupling	Primary/Secondary Aliphatic Amines	0 °C	Reaction is typically fast and exothermic. [4]
Primary/Secondary Aromatic Amines	0 °C to Room Temperature	May require slightly higher temperatures or a catalyst (DMAP) for less nucleophilic anilines.	
Sterically Hindered Amines	Room Temperature (with catalyst)	Optimization may be required; avoid high temperatures.	
Friedel-Crafts Acylation	Electron-Rich Arenes (e.g., Anisole)	-10 °C to 0 °C	Lower temperatures improve selectivity and prevent side reactions.[8]
Neutral/Slightly Activated Arenes (e.g., Benzene, Toluene)	0 °C to 5 °C	Standard conditions; may be warmed to room temperature.[8]	
Deactivated Arenes	Room Temperature to 50 °C	High risk of ring-opening and other side reactions. Use with caution.	

Experimental Protocol: General Procedure for Amide Synthesis (Schotten-Baumann Conditions)

- In a round-bottom flask equipped with a magnetic stirrer, dissolve the amine (1.0 eq.) and a suitable base such as triethylamine (1.1-1.5 eq.) in an appropriate anhydrous solvent (e.g., dichloromethane, THF).[6]

- Cool the stirred solution to 0 °C in an ice bath.
- Add a solution of cyclopropanecarbonyl chloride (1.05 eq.) in the same anhydrous solvent dropwise to the amine solution over 15-30 minutes, ensuring the internal temperature does not rise significantly.
- After the addition is complete, allow the reaction mixture to stir at 0 °C for 30 minutes, then warm to room temperature and stir for 1-3 hours.
- Monitor the reaction progress by TLC or LC-MS.
- Upon completion, quench the reaction by adding water. Extract the product with an organic solvent.
- Wash the organic layer sequentially with a dilute acid (e.g., 1N HCl), saturated sodium bicarbonate solution, and brine.
- Dry the organic layer over anhydrous sodium sulfate, filter, and concentrate under reduced pressure to yield the crude amide, which can be purified by recrystallization or column chromatography.

Experimental Protocol: General Procedure for Friedel-Crafts Acylation

- To a flame-dried, three-necked round-bottom flask equipped with a magnetic stirrer, a dropping funnel, and a nitrogen inlet, add the Lewis acid (e.g., AlCl₃, 1.1 eq.) and an anhydrous solvent (e.g., dichloromethane).
- Cool the suspension to the desired starting temperature (e.g., 0 °C) in an appropriate cooling bath.
- Add a solution of cyclopropanecarbonyl chloride (1.0 eq.) in the anhydrous solvent to the dropping funnel and add it dropwise to the stirred Lewis acid suspension, maintaining the low temperature.
- After the addition is complete, add the aromatic substrate (1.0-1.2 eq.) dropwise to the reaction mixture.

- Stir the reaction at the optimized temperature for the required time, monitoring its progress by TLC or GC-MS.
- Upon completion, carefully quench the reaction by slowly pouring it over crushed ice and dilute acid (e.g., 1N HCl).
- Separate the layers and extract the aqueous layer with the organic solvent.
- Combine the organic layers, wash with water and brine, dry over anhydrous sodium sulfate, filter, and concentrate under reduced pressure.
- Purify the resulting cyclopropyl aryl ketone by column chromatography or distillation.

Part 4: Visualizations

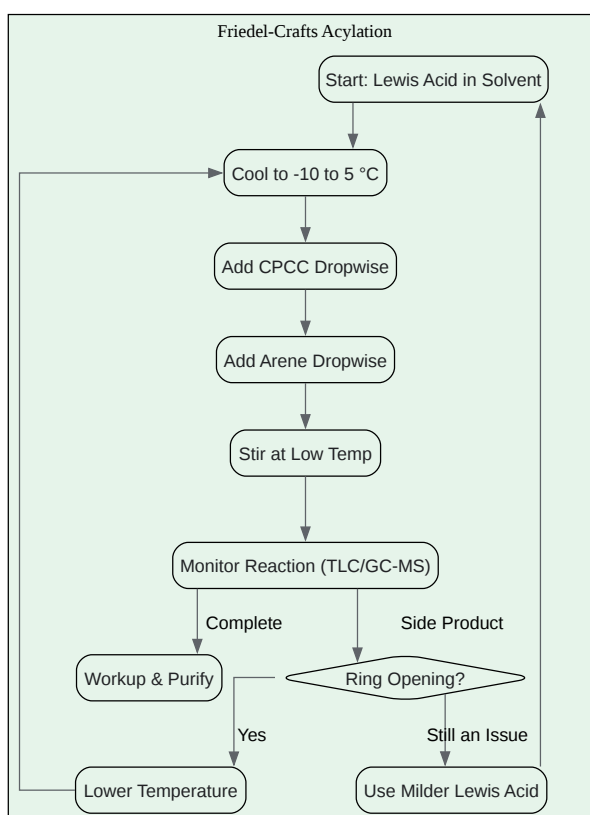
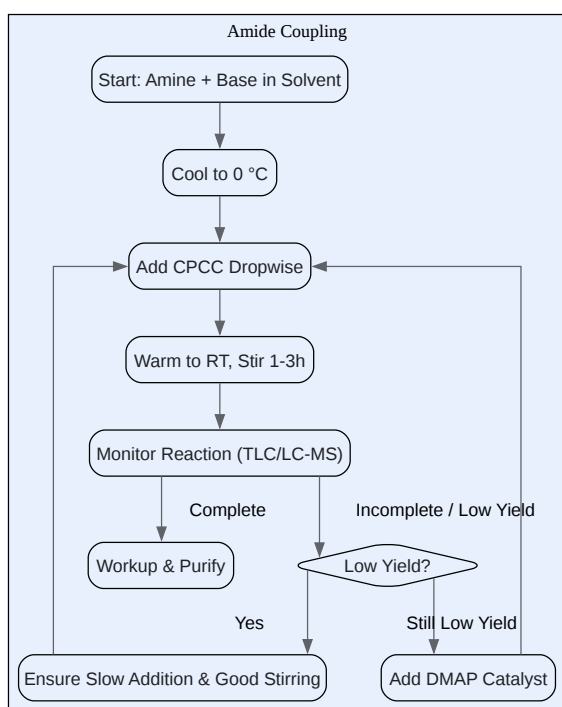

[Click to download full resolution via product page](#)

Caption: Workflow for optimizing reaction temperature in CPCC couplings.

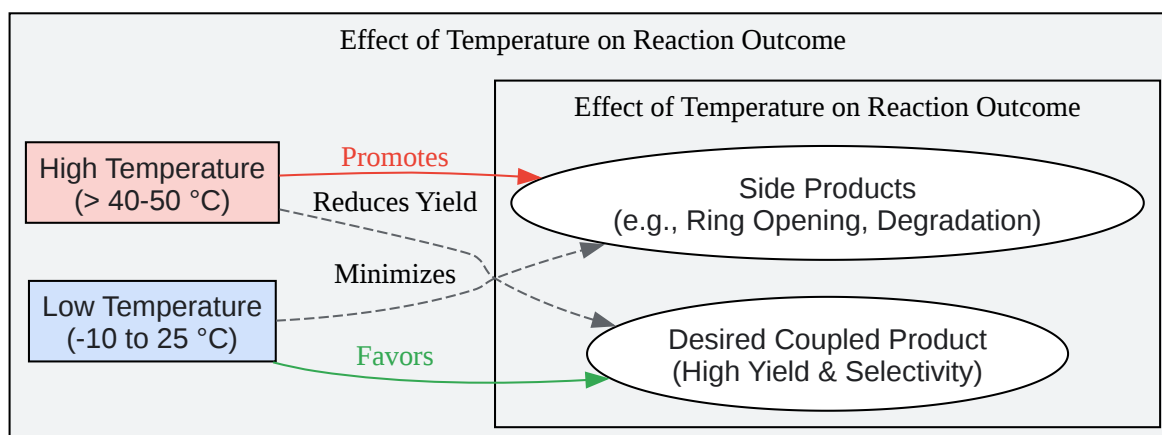

[Click to download full resolution via product page](#)

Caption: General effect of temperature on CPCC coupling reactions.

References

- BenchChem. (2025).
- Crabtree, S. P., et al. (2011). Friedel–Crafts Reactions of 2,2-Difluorocyclopropanecarbonyl Chloride: Unexpected Ring-Opening Chemistry. *The Journal of Organic Chemistry*, 76(9), 3563-3566.
- Otto Chemie Pvt. Ltd. (n.d.). Cyclopropanecarbonyl chloride, 98% 4023-34-1 India. Retrieved from [\[Link\]](#)
- BenchChem. (2025). How to avoid ring-opening of cyclopropyl ketones during reaction. BenchChem.
- Clarke, C. J., et al. (2017). Synthesis of Amides from Acid Chlorides and Amines in the Bio-based Solvent Cyrene™. *Green Chemistry*, 19(23), 5625-5629.
- Saha, D., et al. (2024). Ring-opening of cyclopropyl ketones followed by cyanation for the... *Chemistry – An Asian Journal*.
- Pure and Applied Chemistry. (2021). Kinetic study and modeling of the Schotten-Baumann synthesis of peroxyesters using phase-Transfer catalysts in. *Pure and Applied Chemistry*, 93(1), 83-95.
- SATHEE. (n.d.). Chemistry Schotten Baumann Reaction. Retrieved from [\[Link\]](#)

- UCL Discovery. (n.d.). Radical Ring Opening Reactions of the Cyclopropylcarbinyl Systems. Retrieved from [[Link](#)]
- Mayr, H., et al. (2019). Reactivity of electrophilic cyclopropanes. *Beilstein Journal of Organic Chemistry*, 15, 2045-2074.
- Grokipedia. (n.d.). Schotten–Baumann reaction. Retrieved from [[Link](#)]
- Name Reactions in Organic Synthesis. (n.d.). Schotten-Baumann Reaction. Cambridge University Press.
- Royal Society of Chemistry. (2022). Multi-objective Bayesian optimisation using q-noisy expected hypervolume improvement (qNEHVI) for the Schotten–Baumann reaction. *Digital Discovery*, 1, 623-630.
- Catrin. (2023). Scientists introduce unprecedented and highly creative approach to amide synthesis. Retrieved from [[Link](#)]
- MDPI. (2024). Design, Synthesis, and Antimicrobial Activity of Amide Derivatives Containing Cyclopropane. *Molecules*, 29(17), 4099.
- BenchChem. (2025). Application Notes and Protocols: Reactions of (2,2-dichloroethenyl)cyclopropane with Nucleophiles. BenchChem.
- Beilstein Journal of Organic Chemistry. (2019). Reactivity of electrophilic cyclopropanes. *Beilstein Journal of Organic Chemistry*, 15, 2045-2074.
- Chemistry Steps. (2020). Reactions of Acid Chlorides (ROCl) with Nucleophiles. Retrieved from [[Link](#)]
- ResearchGate. (2019). Cyclization reactions of cyclopropane derivatives with conjugated carbo- and heterosystems. *Russian Chemical Reviews*, 88(10), 1057-1099.

Need Custom Synthesis?

BenchChem offers custom synthesis for rare earth carbides and specific isotopic labeling.

Email: info@benchchem.com or [Request Quote Online](#).

Sources

- 1. guidechem.com [guidechem.com]

- [2. Cyclopropanecarbonyl chloride, 98% 25 g | Buy Online | Thermo Scientific Chemicals | Fisher Scientific \[fishersci.com\]](#)
- [3. Cyclopropanecarbonyl Chloride \(CPCC\): What You Need to Know - Ketone Pharma \[ketonepharma.com\]](#)
- [4. Twenty-nine Methods for Amide Synthesis: Mechanisms, Characteristics, Applications, and Selection \[bocsci.com\]](#)
- [5. Lab Reporter \[fishersci.co.uk\]](#)
- [6. pure.hud.ac.uk \[pure.hud.ac.uk\]](#)
- [7. Page loading... \[wap.guidechem.com\]](#)
- [8. pubs.acs.org \[pubs.acs.org\]](#)
- [9. pdf.benchchem.com \[pdf.benchchem.com\]](#)
- [10. Cyclopropanecarbonyl Chloride | 4023-34-1 \[chemicalbook.com\]](#)
- [11. 环丙甲酰氯 98% | Sigma-Aldrich \[sigmaaldrich.com\]](#)
- [12. Cyclopropanecarbonyl chloride, 98% 4023-34-1 India \[ottokemi.com\]](#)
- [13. labproinc.com \[labproinc.com\]](#)
- [14. SATHEE: Chemistry Schotten Baumann Reaction \[sathee.iitk.ac.in\]](#)
- [15. grokipedia.com \[grokipedia.com\]](#)
- [16. api.repository.cam.ac.uk \[api.repository.cam.ac.uk\]](#)
- [To cite this document: BenchChem. \[Technical Support Center: Optimizing Reaction Temperature for Cyclopropanecarbonyl Chloride Coupling\]. BenchChem, \[2026\]. \[Online PDF\]. Available at: \[https://www.benchchem.com/product/b290456/docs#technical-support-center-optimizing-reaction-temperature-for-cyclopropanecarbonyl-chloride-coupling\]](#)

Disclaimer & Data Validity:

The information provided in this document is for Research Use Only (RUO) and is strictly not intended for diagnostic or therapeutic procedures. While BenchChem strives to provide accurate protocols, we make no warranties, express or implied, regarding the fitness of this product for every specific experimental setup.

Technical Support: The protocols provided are for reference purposes. Unsure if this reagent suits your experiment?

Need Industrial/Bulk Grade? [Request Custom Synthesis Quote](#)

BenchChem

Our mission is to be the trusted global source of essential and advanced chemicals, empowering scientists and researchers to drive progress in science and industry.

Contact

Address: 3281 E Guasti Rd
Ontario, CA 91761, United States
Phone: (601) 213-4426
Email: info@benchchem.com

[Contact our Ph.D. Support Team for a compatibility check](#)