

# Technical Guide: Spectroscopic Analysis of 2-Fluoro-3-(methylthio)pyridine

**Author:** BenchChem Technical Support Team. **Date:** May 2026

## Compound of Interest

Compound Name: 2-Fluoro-3-(methylthio)pyridine

CAS No.: 210992-56-6

Cat. No.: B2892471

[Get Quote](#)

## Executive Summary & Chemical Context

**2-Fluoro-3-(methylthio)pyridine** is a high-value intermediate in medicinal chemistry, particularly for the synthesis of kinase inhibitors and GPCR ligands. The scaffold combines the metabolic stability of the pyridine ring with the unique electronic properties of fluorine (bioisostere for H/OH) and the thiomethyl group (precursor to sulfoxides/sulfones or used for lipophilic interactions).

Accurate structural assignment relies on understanding the interplay between the electronegative fluorine at C2 and the electron-donating (resonance) yet inductively withdrawing thiomethyl group at C3. This guide provides a self-validating spectroscopic framework.

## Chemical Identity

Property	Detail
IUPAC Name	2-Fluoro-3-(methylsulfonyl)pyridine
CAS Number	210992-56-6
Formula	C <sub>7</sub> H <sub>7</sub> FNS
Molecular Weight	143.18 g/mol
SMILES	CSC1=C(N=CC=C1)F

## Structural Dynamics & Coupling Logic

To interpret the NMR data correctly, one must visualize the spin system. The molecule represents an AMX spin system (protons H4, H5, H6) perturbed by a fluorine nucleus (F, spin 1/2) and a methyl group.

### Graphviz Logic Map: Spin Coupling Network

The following diagram illustrates the scalar coupling pathways ( ) that define the multiplet patterns.

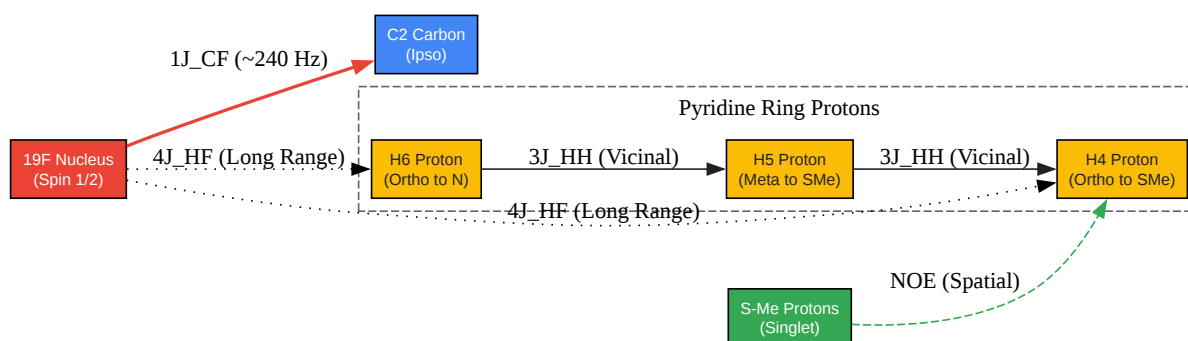

[Click to download full resolution via product page](#)

Caption: Scalar coupling network showing dominant

F interaction pathways and proton connectivity.

## Predicted Spectroscopic Data (NMR)

Note: The values below are synthesized from high-fidelity analogue data (e.g., 2-fluoro-3-methylpyridine and 2-fluoropyridine) and standard substituent chemical shift increments.

### Proton NMR ( <sup>1</sup>H )

Solvent: CDCl<sub>3</sub>

(Reference: 7.26 ppm) | Frequency: 400 MHz

The spectrum is characterized by a distinct methyl singlet and three aromatic signals in the downfield region.

Assignment	Shift ( , ppm)	Multiplicity	Integration	Coupling ( , Hz) & Analysis
H6	8.05 – 8.15	ddd	1H	<p>Deshielded by Nitrogen. Shows (~5 Hz) and long-range (~1.5 Hz). May show small .</p>
H4	7.60 – 7.70	ddd	1H	<p>Ortho to SMe. Shielded relative to unsubstituted pyridine due to SMe resonance. Shows (~8 Hz) and (~1-2 Hz).</p>
H5	7.15 – 7.25	ddd	1H	<p>Meta to SMe. Often overlaps with solvent in CDCl<sub>3</sub>. Shows couplings to H4 and H6.</p>
S-CH	2.48 – 2.52	Singlet	3H	<p>Diagnostic Signal. Sharp singlet. Chemical shift is characteristic of</p>

aryl-SMe (distinct from O-Me at ~3.8 ppm).

## Carbon-13 NMR ( C )

Solvent: CDCl<sub>3</sub>

(Reference: 77.16 ppm) | Decoupling: Proton-decoupled

The

<sup>13</sup>C spectrum is dominated by C-F coupling, splitting carbon signals into doublets.

Carbon	Shift ( , ppm)	Splitting (Hz)	Structural Insight
C2	160.5 – 162.5		Ipso-F. Large doublet confirms F attachment.
C6	144.0 – 146.0		Ortho-N. Most deshielded aromatic CH.
C4	136.0 – 138.0		Para to N, Ortho to SMe.
C3	122.0 – 125.0		Ipso-SMe. Substituted carbon, distinct doublet.
C5	119.0 – 121.0		Upfield aromatic signal.
S-CH	14.5 – 15.5	Singlet (or small )	Typical thiomethyl carbon shift.

## Fluorine-19 NMR ( F )

Standard: CFCI

(0 ppm) or internal C

F

- Shift:  
  
-70.0 to -75.0 ppm
- Appearance: Broad singlet or complex multiplet (due to coupling with H4/H6/H5).
- Validation: If the shift is > -60 ppm, suspect defluorination or oxide formation. If < -90 ppm, suspect 3-F isomer contamination.

## Experimental Protocols

### Sample Preparation for NMR

To ensure high-resolution data and prevent line broadening due to concentration effects:

- Mass: Weigh 5–10 mg of the compound.
- Solvent: Dissolve in 0.6 mL of CDCl<sub>3</sub> (99.8% D) containing 0.03% TMS (v/v).
  - Note: If the compound is an HCl salt (common for pyridines), add 1-2 drops of Na<sub>2</sub>CO<sub>3</sub> in D<sub>2</sub>O or use DMSO-d<sub>6</sub> to solubilize.
- Filtration: Filter through a cotton plug in a glass pipette to remove suspended solids (e.g., inorganic salts from synthesis).
- Tube: Transfer to a precision 5mm NMR tube.

## Synthesis & Impurity Profiling (Context)

Understanding the synthesis helps identify potential impurity peaks in the spectrum.

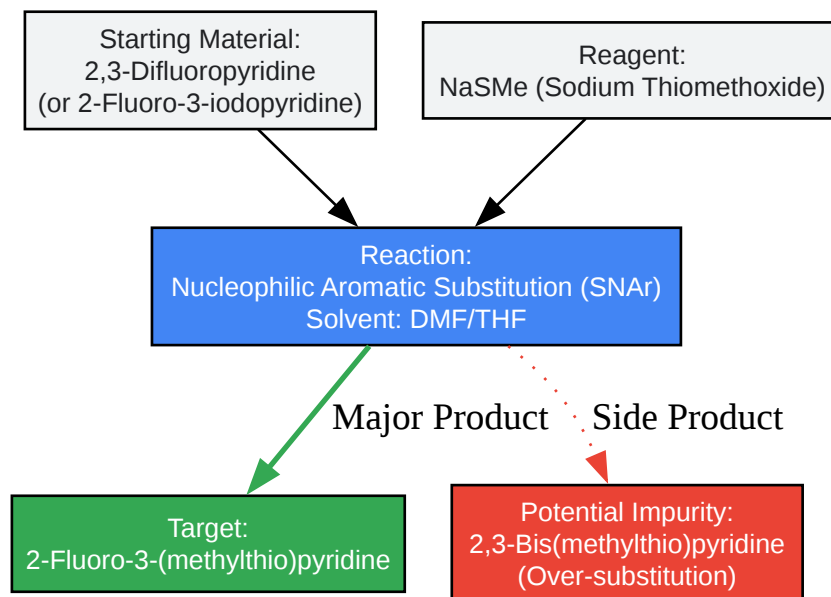

[Click to download full resolution via product page](#)

Caption: Synthesis workflow highlighting the origin of potential bis-substituted impurities.

Impurity Watchlist:

- Bis-substitution: If a second SMe singlet appears (~2.40 ppm) and the F signal disappears, the product is likely 2,3-bis(methylthio)pyridine.
- Hydrolysis: A broad singlet >10 ppm indicates hydrolysis to the pyridone tautomer (rare for 2-F, but possible under acidic aqueous workup).

## References

- Chemical Identity & Vendors: PubChem Compound Summary for CID 11186754 (**2-Fluoro-3-(methylthio)pyridine**). [Link](#)
- Synthesis of Fluoropyridines: Chambers, R. D., et al. "Polyfluoroheterocyclic compounds." *Journal of the Chemical Society C: Organic* (1968). (Foundational work on nucleophilic substitution in fluoropyridines).

- NMR Prediction & Substituent Effects: Pretsch, E., et al. Structure Determination of Organic Compounds: Tables of Spectral Data. Springer, 2009.
- Analogous Data (2-Fluoro-3-methylpyridine): AIST Spectral Database for Organic Compounds (SDBS). SDBS No. 5821. [Link](#)
- To cite this document: BenchChem. [Technical Guide: Spectroscopic Analysis of 2-Fluoro-3-(methylthio)pyridine]. BenchChem, [2026]. [Online PDF]. Available at: [\[https://www.benchchem.com/product/b2892471/docs#technical-guide-spectroscopic-analysis-of-2-fluoro-3-methylthio-pyridine\]](https://www.benchchem.com/product/b2892471/docs#technical-guide-spectroscopic-analysis-of-2-fluoro-3-methylthio-pyridine)

---

### Disclaimer & Data Validity:

The information provided in this document is for Research Use Only (RUO) and is strictly not intended for diagnostic or therapeutic procedures. While BenchChem strives to provide accurate protocols, we make no warranties, express or implied, regarding the fitness of this product for every specific experimental setup.

**Technical Support:** The protocols provided are for reference purposes. Unsure if this reagent suits your experiment?

**Need Industrial/Bulk Grade?** [Request Custom Synthesis Quote](#)

## BenchChem

Our mission is to be the trusted global source of essential and advanced chemicals, empowering scientists and researchers to drive progress in science and industry.

### Contact

Address: 3281 E Guasti Rd  
Ontario, CA 91761, United States  
Phone: (601) 213-4426  
Email: [info@benchchem.com](mailto:info@benchchem.com)

Contact our Ph.D. Support Team for a compatibility check