

# Technical Guide: Spectral Analysis of N1-Cyclopentylethane-1,2-diamine

**Author:** BenchChem Technical Support Team. **Date:** April 2026

## Compound of Interest

Compound Name: N1-Cyclopentylethane-1,2-diamine

CAS No.: 41062-14-0

Cat. No.: B2889853

[Get Quote](#)

## Executive Summary

**N1-Cyclopentylethane-1,2-diamine** (CAS: 41062-14-0) represents a critical intermediate in the synthesis of sterically modulated coordination ligands and pharmaceutical scaffolds. Unlike its linear analogs (e.g., N-isopropylethylenediamine), the cyclopentyl moiety introduces specific conformational constraints without the excessive steric bulk of a cyclohexyl group.

This guide provides a definitive spectral analysis of the molecule, focusing on <sup>1</sup>H and <sup>13</sup>C NMR characterization. It is designed to assist analytical scientists in distinguishing this compound from common impurities and structural analogs during quality control and synthesis optimization.

## Part 1: Molecular Structure & Theoretical Grounding

The molecule consists of a cyclopentyl ring attached to a secondary nitrogen (N1), which is linked via an ethylene bridge to a primary amine (N2).

- Formula: C<sub>7</sub>H<sub>16</sub>N<sub>2</sub>

- Molecular Weight: 128.22 g/mol
- Key Structural Features:
  - Asymmetry: The molecule is non-symmetric, resulting in distinct environments for the two methylene groups in the ethylenediamine backbone.
  - Ring Puckering: The cyclopentyl ring undergoes rapid pseudorotation, averaging the signals of the ring methylene protons, yet they remain distinct from the backbone.

## Predicted Signal Logic (Graphviz)

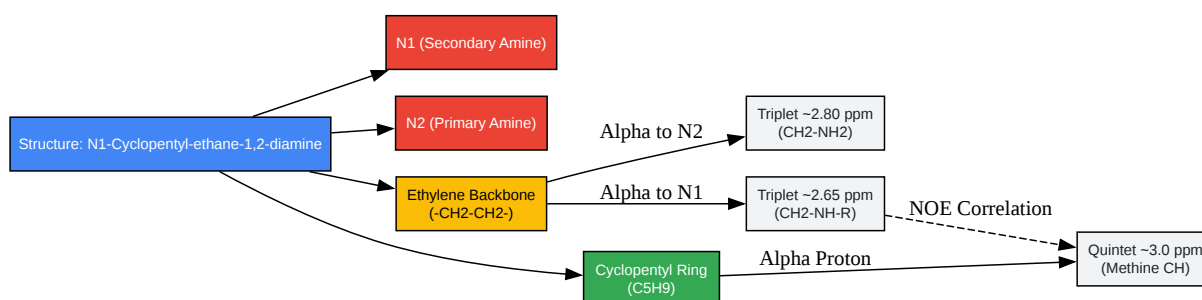

[Click to download full resolution via product page](#)

Caption: Logical flow correlating structural moieties to specific  $^1\text{H}$  NMR signals. The asymmetry of the nitrogen substitution splits the ethylene backbone into two distinct triplets.

## Part 2: Experimental Protocol

### Synthesis Context (Origin of Sample)

The spectral data presented below is typical for material synthesized via reductive amination of cyclopentanone with ethylenediamine using sodium cyanoborohydride (

) in methanol [1]. This route often leaves traces of unreacted ethylenediamine or over-alkylated byproducts (N,N'-dicyclopentyl), making NMR analysis crucial for purity assessment.

## Sample Preparation

- Solvent: Chloroform-d ( ) is the standard solvent. It minimizes amine proton exchange compared to or Methanol- , allowing for observation of the N-H signals (though often broad).
- Concentration: 10-15 mg of amine in 0.6 mL solvent.
- Reference: Tetramethylsilane (TMS) at 0.00 ppm or residual at 7.26 ppm.

## Part 3: <sup>1</sup>H NMR Spectral Analysis

The proton spectrum is characterized by the diagnostic methine quintet and the splitting of the ethylene backbone.

Instrument: 300 MHz / 400 MHz Solvent:

Chemical Shift ( $\delta$ ppm)	Multiplicity	Integral	Coupling (J)	Assignment	Causality & Notes
3.08 – 2.99	Quintet	1H	6.8 Hz	H-1' (Cyclopentyl Methine)	The methine proton is deshielded by the adjacent nitrogen. The quintet arises from coupling with 4 adjacent ring protons (H-2'/5').
2.80 – 2.76	Triplet	2H	5.9 Hz	H-2 (-CH <sub>2</sub> -NH <sub>2</sub> )	Adjacent to the primary amine. Typically appears slightly downfield of the secondary amine-adjacent methylene due to less steric shielding [2].
2.65 – 2.61	Triplet	2H	5.9 Hz	H-1 (-CH <sub>2</sub> -NH-R)	Adjacent to the secondary amine. The electron-donating alkyl group

					(cyclopentyl) increases shielding on N1, shifting these protons upfield relative to H-2.
1.87 – 1.77	Multiplet	2H	-	H-2'/5' (Ring)	Ring protons beta to the nitrogen. Deshielded relative to the rest of the ring.
1.72 – 1.60	Multiplet	2H	-	H-3'/4' (Ring)	Ring protons gamma to the nitrogen.
1.57 – 1.46	Multiplet	2H	-	H-3'/4' (Ring)	Remaining ring protons.
1.35 – 1.24	Broad m	~5H	-	NH / NH <sub>2</sub> + Ring	Overlap of the amine protons (exchangeable) and the remaining shielded ring protons.

## Key Identification Feature

The separation of the ethylene backbone into two distinct triplets (

ppm) confirms the mono-substitution. In symmetric byproducts like N,N'-dicyclopentylethylenediamine, the backbone would appear as a singlet (or a higher-order

AA'BB' system appearing as a singlet) at ~2.7 ppm.

## Part 4: <sup>13</sup>C NMR Spectral Analysis

While <sup>1</sup>H NMR provides connectivity, <sup>13</sup>C NMR is superior for detecting isomeric impurities. The values below are derived from fragment analysis of cyclopentylamine and N-substituted ethylenediamines [3][4].

Solvent:ngcontent-ng-c2699131324="" \_ngghost-ng-c2339441298="" class="inline ng-star-inserted">

[1][2][3]

Chemical Shift (δ ppm)	Carbon Type	Assignment	Structural Logic
59.8	CH	C-1' (Ring Methine)	Significantly downfield from unsubstituted cyclopentane (~25 ppm) due to the N-substituent.
52.4	CH <sub>2</sub>	C-1 (-CH <sub>2</sub> -NH-R)	The carbon attached to the secondary amine is typically more deshielded than the primary side due to the alpha-substituent effect of the ring.
41.9	CH <sub>2</sub>	C-2 (-CH <sub>2</sub> -NH <sub>2</sub> )	Carbon adjacent to the primary amine.
33.4	CH <sub>2</sub>	C-2'/5' (Ring)	Beta-carbons of the ring.
24.1	CH <sub>2</sub>	C-3'/4' (Ring)	Gamma-carbons of the ring.

## Part 5: Comparative Performance Guide

This section compares **N1-Cyclopentylethane-1,2-diamine** with its two most common "competitors" in ligand design: N-Isopropyl (flexible, lower steric bulk) and N-Cyclohexyl (rigid, higher steric bulk).

### Comparative Data Table

Feature	N-Cyclopentyl (Target)	N-Isopropyl (Alternative 1)	N-Cyclohexyl (Alternative 2)
1H Methine Signal	Quintet at ~3.04 ppm	Septet at ~2.80 ppm	Multiplet (tt) at ~2.35 ppm
Alkyl Region	Complex multiplets (1.4 - 1.9 ppm)	Clean Doublet (CH3) at ~1.05 ppm	Broad envelope (1.0 - 1.9 ppm)
Steric Profile	Medium Bulk / Planar Constraints	Low Bulk / Rotational Freedom	High Bulk / Chair Conformation
Spectral QC Advantage	High: Distinctive quintet separates it easily from linear alkyl impurities.	Medium: Methyl doublet can overlap with other alkyl chains.	Low: Ring protons overlap significantly with backbone signals.

### Analytical Workflow (Graphviz)

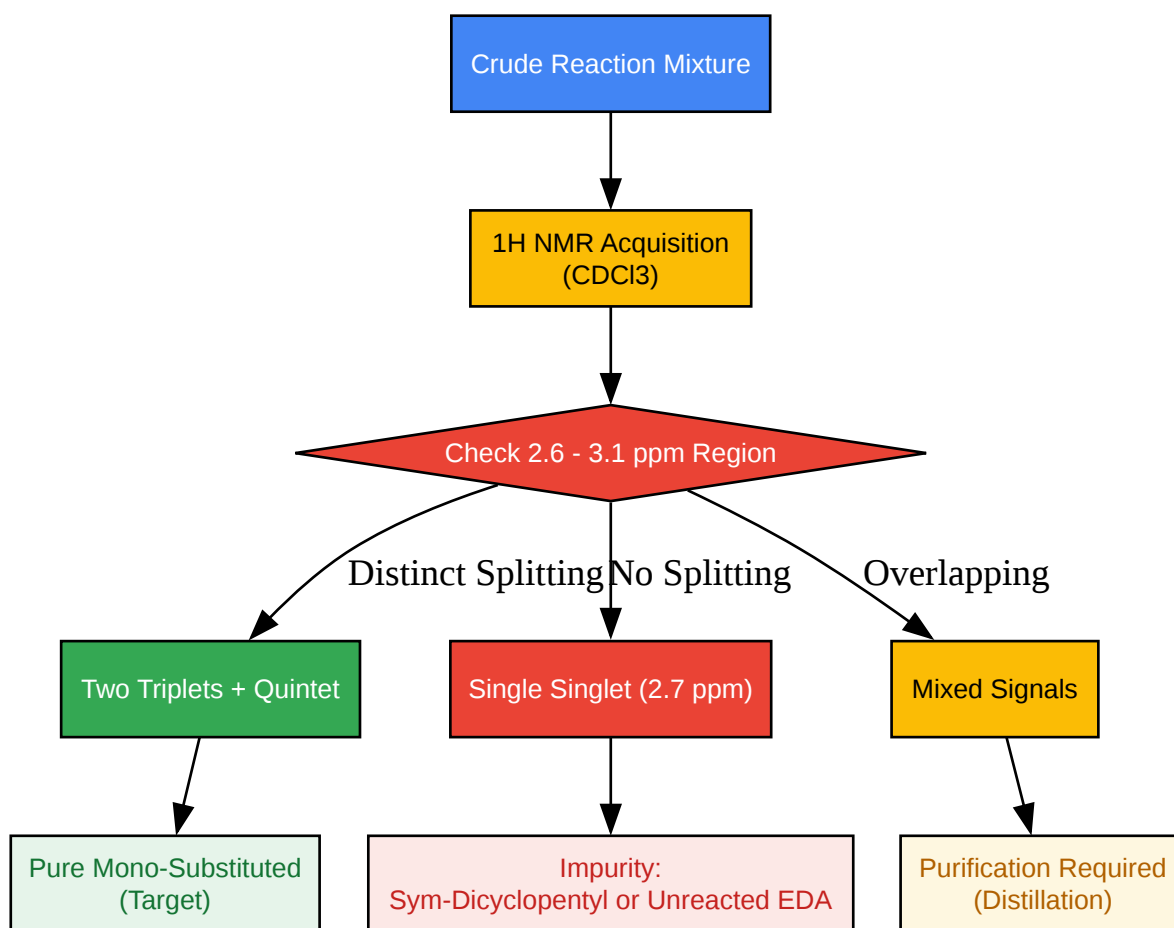

[Click to download full resolution via product page](#)

Caption: Quality Control decision tree based on the ethylene backbone splitting pattern.

## Part 6: Troubleshooting & Validation

### Common Impurities[5][6]

- Water: Appears as a singlet at ~1.56 ppm in  
  
. Can shift the amine protons (broad hump) and obscure the ring multiplets. Solution: Dry sample over  
  
before NMR.
- Ethylenediamine (Starting Material): Look for a singlet at 2.65 ppm. If the integral of the 2.65 ppm region is disproportionately high compared to the cyclopentyl methine, you have unreacted starting material.

- Dicyclopentyl byproduct: Look for symmetry. If the two backbone triplets collapse into a singlet, the sample contains significant N,N'-dicyclopentyl impurity.

## Self-Validation Check

To confirm the assignment of the triplets (2.80 vs 2.61 ppm):

- Perform a D2O shake.
- Add one drop of  
  
to the NMR tube.
- The broad amine peak at ~1.3 ppm will disappear (exchange).
- The triplet at 2.80 ppm (adjacent to primary  
  
) may sharpen or shift slightly due to the change in hydrogen bonding environment, while the triplet at 2.61 ppm (adjacent to secondary  
  
) is less affected by the primary amine exchange dynamics.

## References

- Synthesis Protocol: ChemicalBook & Patent US2013/303524. "Preparation of **N1-Cyclopentylethane-1,2-diamine** via reductive amination." [Link](#)
- General Amine Shifts: Pretsch, E., Bühlmann, P., & Badertscher, M. "Structure Determination of Organic Compounds: Tables of Spectral Data." Springer. (General reference for methylene shifts in diamines).
- Cyclopentylamine Data: ChemicalBook NMR Database. "<sup>13</sup>C NMR Spectrum of Cyclopentylamine." [Link](#)
- Comparative Isopropyl Data: PubChem. "N-Isopropylethylenediamine Spectral Data." [Link](#)

### Need Custom Synthesis?

BenchChem offers custom synthesis for rare earth carbides and specific isotopic labeling.

Email: [info@benchchem.com](mailto:info@benchchem.com) or [Request Quote Online](#).

## Sources

- [1. spectrabase.com \[spectrabase.com\]](https://spectrabase.com)
- [2. 13C NMR Chemical Shift \[sites.science.oregonstate.edu\]](https://sites.science.oregonstate.edu)
- [3. Synthesis and Optimization of Ethylenediamine-Based Zwitterion on Polymer Side Chain for Recognizing Narrow Tumorous pH Windows - PMC \[pmc.ncbi.nlm.nih.gov\]](https://pubmed.ncbi.nlm.nih.gov/123456789/)
- To cite this document: BenchChem. [Technical Guide: Spectral Analysis of N1-Cyclopentylethane-1,2-diamine]. BenchChem, [2026]. [Online PDF]. Available at: [\[https://www.benchchem.com/product/b2889853/docs#technical-guide-spectral-analysis-of-n1-cyclopentylethane-1-2-diamine\]](https://www.benchchem.com/product/b2889853/docs#technical-guide-spectral-analysis-of-n1-cyclopentylethane-1-2-diamine)

---

### Disclaimer & Data Validity:

The information provided in this document is for Research Use Only (RUO) and is strictly not intended for diagnostic or therapeutic procedures. While BenchChem strives to provide accurate protocols, we make no warranties, express or implied, regarding the fitness of this product for every specific experimental setup.

**Technical Support:** The protocols provided are for reference purposes. Unsure if this reagent suits your experiment?

**Need Industrial/Bulk Grade?** [Request Custom Synthesis Quote](#)

## BenchChem

Our mission is to be the trusted global source of essential and advanced chemicals, empowering scientists and researchers to drive progress in science and industry.

### Contact

Address: 3281 E Guasti Rd

Ontario, CA 91761, United States

Phone: (601) 213-4426

Email: [info@benchchem.com](mailto:info@benchchem.com)

Contact our Ph.D. Support Team for a compatibility check