

Advanced Synthesis of Quinazolinones: Methyl Anthranilate Pathways

Author: BenchChem Technical Support Team. **Date:** April 2026

Compound of Interest

Compound Name: Methyl 2-[(2-chloropropanoyl)amino]benzoate

CAS No.: 72544-42-4

Cat. No.: B2889592

[Get Quote](#)

Strategic Overview: The Methyl Anthranilate Advantage

The quinazolin-4(3H)-one scaffold is a pharmacophore of immense significance, serving as the structural core for diverse bioactive agents ranging from sedative-hypnotics (e.g., Methaqualone) to modern kinase inhibitors (e.g., Idelalisib analogs). While isatoic anhydride is a common precursor, Methyl Anthranilate (MA) and its derivatives offer distinct advantages in industrial scalability and library synthesis:

- **Atom Economy:** Unlike isatoic anhydrides which release CO₂ as a byproduct, MA derivatives can be utilized in condensation reactions where the leaving group is a small alcohol (methanol), often recoverable.
- **Stability:** MA is significantly more stable to moisture and storage than isatoic anhydrides or anthraniloyl chlorides, reducing degradation during long-term storage or automated handling in high-throughput screening (HTS) campaigns.

- **Diversity:** The ester moiety allows for direct nucleophilic attack by diverse amines, facilitating the rapid generation of 2,3-disubstituted libraries without the need for aggressive activating agents.

This guide details the mechanistic pathways, optimized protocols, and experimental logic for leveraging methyl anthranilate in the synthesis of high-value quinazolinone targets.

Mechanistic Pathways

The Modified Niementowski Reaction

The classical Niementowski synthesis involves the condensation of anthranilic acid with amides at high temperatures (180–200 °C). Using methyl anthranilate lowers the activation energy barrier when coupled with Lewis acids or microwave irradiation.

Mechanism:

- **Nucleophilic Attack:** The amine of the reaction partner (e.g., an amide or nitrile) attacks the ester carbonyl of MA.
- **Cyclization:** Intramolecular condensation occurs between the newly formed amide nitrogen and the ortho-nitrogen.
- **Dehydration/Elimination:** Loss of methanol and/or water drives the aromatization to the quinazolinone core.

Iodine-Catalyzed Oxidative Cyclization

A modern, metal-free approach utilizes molecular iodine to catalyze the condensation of MA (or its amide derivative) with aldehydes or alcohols. This route is preferred for synthesizing 2-aryl-quinazolin-4(3H)-ones under mild conditions.

Key Insight: Iodine acts as a mild Lewis acid to activate the carbonyl and as an oxidant to dehydrogenate the intermediate aminal to the final aromatic system.

Visualization of Reaction Logic

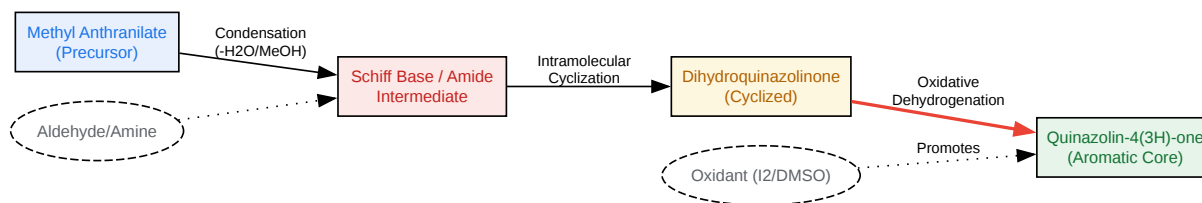

[Click to download full resolution via product page](#)

Figure 1: Mechanistic flow from Methyl Anthranilate to Quinazolinone via oxidative cyclization.

Experimental Protocols

Protocol A: Iodine-Catalyzed Oxidative Synthesis (Metal-Free)

Application: Synthesis of 2-aryl-quinazolin-4(3H)-ones.[1][2] Why this works: The DMSO/I₂ system avoids toxic transition metals and operates at moderate temperatures, preserving sensitive functional groups.

Reagents:

- Methyl Anthranilate (1.0 mmol)
- Aromatic Aldehyde (1.1 mmol)
- Ammonium Acetate (1.2 mmol, nitrogen source)
- Molecular Iodine (10 mol%)
- Solvent: DMSO (acts as solvent and co-oxidant)

Step-by-Step Procedure:

- Charge: In a 10 mL round-bottom flask, combine Methyl Anthranilate (151 mg, 1.0 mmol), the target benzaldehyde (1.1 mmol), and Ammonium Acetate (92 mg, 1.2 mmol).

- Catalyst Addition: Add Molecular Iodine (25 mg, 0.1 mmol) to the mixture.
- Solvation: Add DMSO (3 mL) and stir to ensure homogeneity.
- Reaction: Heat the mixture to 80–100 °C in an oil bath. Monitor via TLC (Ethyl Acetate:Hexane 3:7).
 - Checkpoint: The reaction typically reaches completion in 4–6 hours. The disappearance of the aldehyde spot indicates progress.
- Quench: Cool to room temperature. Pour the reaction mixture into crushed ice (20 g) containing 5% sodium thiosulfate (to quench unreacted iodine).
- Workup: Extract the precipitate with Ethyl Acetate (3 x 10 mL). Wash the organic layer with brine, dry over anhydrous Na₂SO₄, and concentrate in vacuo.
- Purification: Recrystallize from hot ethanol or purify via silica gel column chromatography if necessary.

Protocol B: Microwave-Assisted One-Pot Synthesis

Application: High-throughput library generation of 2,3-disubstituted quinazolinones. Why this works: Microwave irradiation accelerates the condensation and cyclization steps, often eliminating the need for solvent purification or prolonged reflux.

Reagents:

- Methyl Anthranilate (1.0 mmol)
- Orthoester (e.g., Triethyl Orthoformate) (1.5 mmol)
- Primary Amine (1.1 mmol)
- Catalyst: Glacial Acetic Acid (catalytic drops) or acidic alumina support.

Step-by-Step Procedure:

- **Mix:** In a microwave-safe vial (10 mL), mix Methyl Anthranilate (1.0 mmol), Triethyl Orthoformate (1.5 mmol), and the primary amine (1.1 mmol).
- **Catalysis:** Add 2 drops of glacial acetic acid.
- **Irradiation:** Seal the vial and irradiate at 140 °C (Power: 150 W) for 10–15 minutes.
 - **Note:** Use a dynamic power mode to prevent pressure spikes.
- **Cool & Filter:** Allow the vial to cool to 50 °C. Add cold ethanol (2 mL) to the reaction vessel.
- **Isolation:** The product often precipitates upon cooling. Filter the solid and wash with cold diethyl ether.
- **Validation:** Verify purity via LC-MS. This method typically yields >85% purity without chromatography.

Data & Optimization: Comparative Analysis

The choice of method depends heavily on the substitution pattern required at the C-2 and N-3 positions.

Parameter	Classical Thermal (Niementowski)	Iodine-Catalyzed (Protocol A)	Microwave-Assisted (Protocol B)
Reaction Time	12–24 Hours	4–6 Hours	10–20 Minutes
Temperature	>150 °C	80–100 °C	140 °C (Rapid)
Yield (Avg)	40–60%	75–92%	85–95%
Atom Economy	Low (Side reactions common)	High (Oxidative efficiency)	High (One-pot)
Substrate Scope	Limited (Steric hindrance issues)	Broad (Tolerates halides, ethers)	Broad (Aliphatic & Aromatic amines)

Case Study: Drug Development Applications

Methaqualone & Analogs

While Methaqualone is a controlled substance, its synthesis remains the textbook example of the N-acetyl methyl anthranilate pathway.

- **Route:** Methyl anthranilate is first acetylated with acetic anhydride to form Methyl N-acetylanthranilate.
- **Condensation:** This intermediate is condensed with o-toluidine using PCl_3 or POCl_3 as a dehydrating agent.
- **Relevance:** This "two-step" logic is applied in modern medicinal chemistry to synthesize 2-methyl-3-arylquinazolinones, a scaffold investigated for anticonvulsant activity.

Kinase Inhibitor Scaffolds (e.g., Idelalisib Analogs)

Modern PI3K δ inhibitors often feature a quinazolinone core.

- **Strategy:** The iodine-catalyzed oxidative cyclization (Protocol A) allows for the introduction of complex chiral amines at the N-3 position or aryl groups at C-2 without racemization, a critical requirement for synthesizing enantiopure kinase inhibitors.

Workflow for Library Synthesis

Below is a logical workflow for generating a quinazolinone library using Methyl Anthranilate.

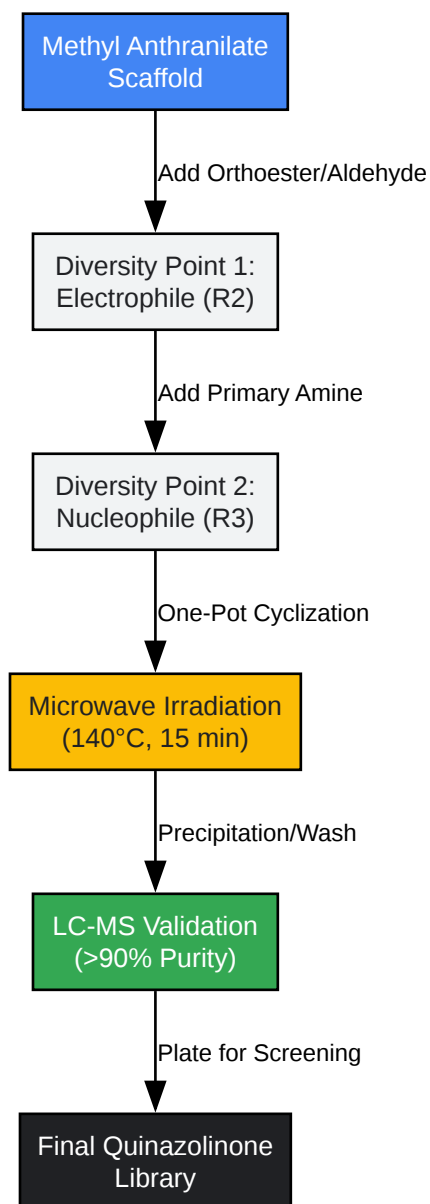

[Click to download full resolution via product page](#)

Figure 2: High-throughput workflow for generating 2,3-disubstituted quinazolinone libraries.

References

- Iodine-Catalyzed Synthesis: Mohammed, S., Vishwakarma, R. A., & Bharate, S. B. (2015).[2] Iodine Catalyzed Oxidative Synthesis of Quinazolin-4(3H)-ones and Pyrazolo[4,3-d]pyrimidin-7(6H)-ones via Amination of sp³ C-H Bond.[1][2] The Journal of Organic Chemistry, 80(13), 6915–6921. [Link](#)

- Microwave-Assisted Protocol: Li, Z., et al. (2008). Microwave-assisted efficient and convenient synthesis of 2,4(1H,3H)-quinazolinones and 2-thioxoquinazolines. *Journal of Combinatorial Chemistry*, 10(3), 484-486. [Link](#)
- One-Pot Multi-Component: Senol, I. M., et al. (2020). One-pot synthesis of quinazolin-4(3H)-ones and 2,3-dihydroquinazolin-4(1H)-ones utilizing N-(2-aminobenzoyl)benzotriazoles. *Turkish Journal of Chemistry*, 44(3). [Link](#)
- Review of Synthetic Strategies: He, L., et al. (2014). Recent Advances in the Synthesis of Quinazolinones. *RSC Advances*. [Link](#)
- Methaqualone Synthesis Context: United Nations Office on Drugs and Crime (UNODC). (2010). [3][4] Recommended Methods for the Identification and Analysis of Methaqualone/Mecloqualone. [Link](#)

Need Custom Synthesis?

BenchChem offers custom synthesis for rare earth carbides and specific isotopic labeling.

Email: info@benchchem.com or [Request Quote Online](#).

Sources

- 1. Iodine Catalyzed Oxidative Synthesis of Quinazolin-4(3H)-ones and Pyrazolo[4,3-d]pyrimidin-7(6H)-ones via Amination of sp³ C-H Bond - PubMed [pubmed.ncbi.nlm.nih.gov]
- 2. Iodine Catalyzed Oxidative Synthesis of Quinazolin-4(3H)-ones and Pyrazolo[4,3-d]pyrimidin-7(6H)-ones via Amination of sp³ C-H Bond [organic-chemistry.org]
- 3. Synthesis and biological activity of raltitrexed-carrier conjugates - PubMed [pubmed.ncbi.nlm.nih.gov]
- 4. [researchgate.net](https://www.researchgate.net) [[researchgate.net](https://www.researchgate.net)]
- To cite this document: BenchChem. [Advanced Synthesis of Quinazolinones: Methyl Anthranilate Pathways]. BenchChem, [2026]. [Online PDF]. Available at: [<https://www.benchchem.com/product/b2889592/docs#advanced-synthesis-of-quinazolinones-methyl-anthranilate-pathways>]

Disclaimer & Data Validity:

The information provided in this document is for Research Use Only (RUO) and is strictly not intended for diagnostic or therapeutic procedures. While BenchChem strives to provide accurate protocols, we make no warranties, express or implied, regarding the fitness of this product for every specific experimental setup.

Technical Support: The protocols provided are for reference purposes. Unsure if this reagent suits your experiment?

Need Industrial/Bulk Grade? [Request Custom Synthesis Quote](#)

BenchChem

Our mission is to be the trusted global source of essential and advanced chemicals, empowering scientists and researchers to drive progress in science and industry.

Contact

Address: 3281 E Guasti Rd
Ontario, CA 91761, United States
Phone: (601) 213-4426
Email: info@benchchem.com

[Contact our Ph.D. Support Team for a compatibility check](#)