

# Technical Support Center: Troubleshooting Cyclization in $\beta$ -Peptide Synthesis

**Author:** BenchChem Technical Support Team. **Date:** April 2026

## Compound of Interest

Compound Name: 3-Amino-3-(2-ethylphenyl)propanoic acid

CAS No.: 299164-93-5

Cat. No.: B2883986

[Get Quote](#)

Welcome to the technical support center for  $\beta$ -peptide synthesis. This guide is designed for researchers, chemists, and drug development professionals who are encountering challenges with unwanted cyclization side reactions. As pioneers in peptide chemistry, we understand that the unique conformational properties of  $\beta$ -amino acids can present significant synthetic hurdles. This resource provides in-depth, experience-driven answers to common problems, explaining not just the solution, but the underlying chemical principles to empower your research.

## Understanding the Core Problem: Why is Cyclization Prevalent in $\beta$ -Peptide Synthesis?

Before diving into troubleshooting, it's crucial to understand the mechanisms driving these side reactions. Unlike  $\alpha$ -peptides, the additional carbon in the backbone of  $\beta$ -peptides imparts distinct conformational preferences. This can lead to two primary cyclization pathways that compete with the desired linear chain elongation:

- **Diketopiperazine (DKP) Formation:** This is the most common issue, occurring at the dipeptide stage. After the N-terminal protecting group (e.g., Fmoc) is removed from the

second amino acid, the newly freed amine can perform an intramolecular "back-attack" on the ester linkage connecting the first amino acid to the solid-phase support. This cleaves the dipeptide from the resin, forming a stable six-membered diketopiperazine ring, which is then washed away, truncating the synthesis.[1][2][3] This reaction is particularly rapid for sequences containing conformationally flexible or turn-inducing residues.[1][4]

- **Head-to-Tail Cyclization:** For longer peptides, especially during solution-phase synthesis or upon cleavage from the resin, the N-terminal amine of a linear peptide can attack its own C-terminal carboxyl group.[5] This intramolecular reaction forms a cyclic peptide, a process that is favored at low concentrations but can occur as an unwanted side reaction under various conditions.[5][6]

Below is a diagram illustrating the competition between desired peptide elongation and the undesired DKP formation pathway.

Fig. 1: Competing pathways after N-terminal deprotection.

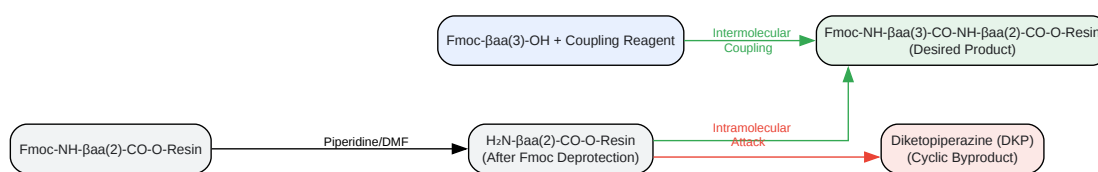

[Click to download full resolution via product page](#)

Fig. 1: Competing pathways after N-terminal deprotection.

## Troubleshooting Guide & FAQs

This section is structured in a question-and-answer format to directly address the issues you may be facing in the lab.

## Q1: My synthesis yield is extremely low, and I suspect DKP formation. How can I confirm this and what is the first thing I should change?

Answer:

Confirming DKP formation is the first critical step. During your synthesis, collect the filtrate from the Fmoc-deprotection step of the third amino acid coupling. Analyze this solution by LC-MS. The presence of a mass corresponding to your dipeptide minus water (M-18) is a strong indicator of DKP formation.

The most effective initial strategy is to change your solid-phase support.<sup>[1]</sup>

- The Problem with Standard Resins: Standard resins like Wang or Rink Amide have linkers that are susceptible to intramolecular attack.
- The Solution: Sterically Hindered Resins: The gold standard for preventing DKP formation is to use a 2-Chlorotriyl Chloride (2-CTC) resin.<sup>[1][4]</sup> The extreme steric bulk of the triyl group physically shields the ester linkage from the N-terminal amine, dramatically reducing the rate of the back-attack reaction.<sup>[1]</sup> This is particularly crucial when the C-terminal or penultimate residue is a secondary amino acid like proline, which is highly prone to this side reaction.<sup>[4]</sup>

Resin Type	Linker Steric Hindrance	Susceptibility to DKP Formation	Recommended Use
Wang	Low	High	General synthesis, avoid for DKP-prone sequences
Rink Amide	Low	High	Synthesis of peptide amides, avoid DKP-prone sequences
2-CTC	Very High	Very Low	Highly recommended for all $\beta$ -peptide synthesis, especially with Pro or Gly at C-terminus[1][6]

## Q2: I'm already using 2-CTC resin but still see some cyclization. How does my choice of coupling reagent impact this?

Answer:

Your coupling reagent is critical. The goal is to make the intermolecular coupling of the next amino acid happen much faster than the intramolecular cyclization. This requires a highly efficient and rapid activation of the incoming carboxylic acid.

- Uronium/Aminium Reagents are Preferred: Reagents like HATU, HBTU, and PyBOP are highly effective.[5][7] They rapidly form activated esters that couple quickly with the free amine on the resin.[5] HATU is often favored for its high coupling efficiency and low rates of racemization.[5]
- Avoid Carbodiimides Alone: Using a carbodiimide like DIC or EDC without an additive is not recommended. The activation can be slower, providing a larger window of opportunity for the deprotected N-terminal amine to initiate cyclization. If you must use a carbodiimide, always include an additive like Oxyma Pure® or HOBT to increase the reaction rate and suppress side reactions.[7]

- **Pre-activation Strategy:** To avoid guanidinylation, where the coupling reagent caps the N-terminus, always pre-activate the amino acid.[4] Mix the protected amino acid with the coupling reagent and a base (like DIPEA) for a few minutes before adding the mixture to the resin. This ensures the activated species is ready for immediate coupling.

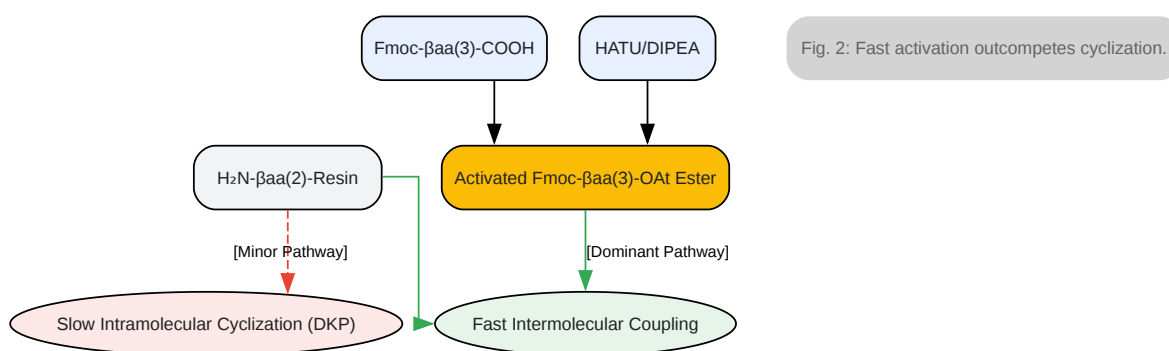

[Click to download full resolution via product page](#)

Fig. 2: Fast activation outcompetes cyclization.

### Q3: Can the N-terminal protecting group itself influence cyclization?

Answer:

Yes, absolutely. While both Fmoc and Boc strategies are common in peptide synthesis, the choice has implications for cyclization.[8]

- **Fmoc Strategy:** The deprotection step in Fmoc chemistry uses a base (typically piperidine). This base creates the free amine that is the nucleophile for the undesired cyclization.[1][3] The persistence of residual base on the resin can promote cyclization even after the deprotection step is complete.[9] Therefore, extremely thorough washing after Fmoc removal is mandatory.

- **Boc Strategy:** In Boc-based synthesis, the N-terminus is deprotected with an acid (like TFA), and the free amine is present as an ammonium salt. A separate neutralization step is required before coupling. Using an in situ neutralization protocol, where the base is added along with the activated amino acid, can suppress DKP formation because the free amine is generated at the same moment the coupling partner is introduced, minimizing its lifetime as a free nucleophile.[4]

## Q4: How do solvent and temperature affect my head-to-tail cyclization yields in solution phase?

Answer:

For solution-phase head-to-tail cyclization, conditions must be optimized to favor the intramolecular reaction over intermolecular polymerization.[5][6]

- **Concentration (High Dilution Principle):** This is the most critical factor. The reaction must be performed under high dilution, typically in the 0.1 to 5 mM range.[5][6] At these low concentrations, a peptide is statistically more likely to encounter its own tail than another peptide molecule, favoring cyclization over oligomerization.
- **Solvent Choice:** The solvent must fully solubilize the linear peptide and encourage a conformation that brings the N- and C-termini into proximity.
  - DMF and DCM are common choices.
  - Polar, aprotic solvents generally work well.
  - For  $\beta$ -peptides, which can form stable secondary structures, the solvent choice can be particularly important.[10][11] Sometimes, adding chaotropic agents like guanidinium chloride can disrupt aggregation and favor the desired folded state for cyclization.[6]
- **Temperature:** The reaction is typically run between 0 °C and room temperature.[5] Lower temperatures minimize the risk of epimerization at the C-terminal residue, a common side reaction during activation.[5] However, slightly elevated temperatures may be required for sterically hindered or conformationally rigid sequences to increase the reaction rate.[12]

## Q5: How can I detect and characterize the cyclic byproducts to troubleshoot effectively?

Answer:

Accurate detection is key. You cannot solve a problem you cannot see.

- LC-MS (Liquid Chromatography-Mass Spectrometry): This is your primary tool.
  - Detection: Cyclic peptides often have different retention times on a reverse-phase HPLC column compared to their linear precursors. Look for new peaks in your chromatogram. The mass of a head-to-tail cyclic peptide will be that of the linear precursor minus the mass of water (18.02 Da). The mass of a DKP byproduct will be the mass of the dipeptide minus water.
  - Characterization: Characterizing cyclic peptides by tandem MS (MS/MS) is more complex than for linear peptides because it requires two backbone cleavages to produce fragment ions.<sup>[13]</sup> Specialized software or manual interpretation is often needed to confirm the sequence from the fragment data.<sup>[13][14][15]</sup>

## Experimental Protocol: Minimizing DKP Formation During SPPS

This protocol outlines a best-practice approach for coupling the third amino acid in a  $\beta$ -peptide sequence, a step highly vulnerable to DKP formation.

- Resin Selection: Begin with the first  $\beta$ -amino acid loaded onto a 2-Chlorotrityl Chloride (2-CTC) resin.
- Synthesis of Dipeptide: Synthesize the dipeptide on the resin using standard Fmoc-SPPS protocols.
- Critical Deprotection Step:
  - Swell the resin in DMF.
  - Treat the resin with 20% piperidine in DMF for 5 minutes. Drain.

- Repeat the treatment with 20% piperidine in DMF for 10 minutes. Drain.
- Crucial Washing: Wash the resin meticulously to remove all residual piperidine. Perform at least 6-8 alternating washes with DMF and DCM.
- Pre-activation of the Third Amino Acid:
  - In a separate vessel, dissolve the third Fmoc- $\beta$ -amino acid (3 eq.), HATU (2.95 eq.), and DIPEA (6 eq.) in DMF.
  - Allow the mixture to pre-activate for 3-5 minutes at room temperature. The solution will typically change color.
- Coupling Reaction:
  - Immediately add the pre-activated amino acid solution to the washed, deprotected dipeptide-resin.
  - Agitate the reaction vessel for 2-4 hours at room temperature.
- Monitoring and Capping:
  - Perform a Kaiser test to check for complete coupling (absence of free primary amines).
  - If the test is positive, consider a second coupling. If it remains positive, cap any unreacted amines with acetic anhydride to prevent the formation of deletion sequences.
- Continuation: Proceed with the synthesis of the rest of your peptide.

## References

- Head-to-Tail Cyclization: A Core Strategy for Cyclic Peptide Synthesis. Vertex AI Search.
- Diketopiperazine Formation (DKP) in Peptide Synthesis: Mechanism, Risks, and Prevention. Vertex AI Search.
- Software-aided detection and structural characterization of cyclic peptide metabolites in biological matrix by high-resolution mass spectrometry - PMC. National Center for Biotechnology Information. [[Link](#)]

- Peptide Side Reactions - Peptide Chemistry | Tools, Guides & Insights. Peptide Chemistry. [\[Link\]](#)
- Optimized Fmoc-Removal Strategy to Suppress the Traceless and Conventional Diketopiperazine Formation in Solid-Phase Peptide Synthesis | ACS Omega. ACS Publications. [\[Link\]](#)
- Understanding diketopiperazine formation mechanism and control strategies during solid phase peptide synthesis of peptide: Impact of solvent, peptide sequence, storage conditions and stabilizer additives. ACS Publications. [\[Link\]](#)
- Mechanistic Study of Diketopiperazine Formation during Solid-Phase Peptide Synthesis of Tirzepatide | ACS Omega. ACS Publications. [\[Link\]](#)
- Aggregation, Racemization and Side Reactions in Peptide Synthesis - AAPPTEC. AAPPTEC. [\[Link\]](#)
- Contemporary strategies for peptide macrocyclization. Nature Reviews Chemistry. [\[Link\]](#)
- Rapid and comprehensive metabolite identification of cyclic peptides - SCIEX. SCIEX. [\[Link\]](#)
- Enhancing Peptide Cyclization: Unveiling the Key Roles of Coupling Reagents and Heat for Optimal Results - PubMed. National Center for Biotechnology Information. [\[Link\]](#)
- A) Influence of the coupling reagent on the cyclization of P5 at rt. B)... - ResearchGate. ResearchGate. [\[Link\]](#)
- Five Tips and Tricks for Success in Solid Phase Peptide Synthesis - Biotage. Biotage. [\[Link\]](#)
- Three Methods for Peptide Cyclization Via Lactamization | Springer Nature Experiments. Springer Nature. [\[Link\]](#)
- Approaches for peptide and protein cyclisation - PMC. National Center for Biotechnology Information. [\[Link\]](#)
- Origin and characterization of cyclodepsipeptides: Comprehensive structural approaches with focus on mass spectrometry analysis of alkali-cationized molecular species - PMC.

National Center for Biotechnology Information. [\[Link\]](#)

- Strategies of peptide cyclization and stabilization of  $\alpha$ -helices,... - ResearchGate. ResearchGate. [\[Link\]](#)
- Cyclic Peptide Analysis - Protein Metrics Support. Protein Metrics. [\[Link\]](#)
- Peptide Modifications; Cyclization; Stapled peptides; phosphorylation; | AAPPTec. AAPPTec. [\[Link\]](#)
- Side reactions in peptide synthesis: An overview - Bibliomed. Bibliomed. [\[Link\]](#)
- Thermodynamic Stability of  $\beta$ -Peptide Helices and the Role of Cyclic Residues - PMC. National Center for Biotechnology Information. [\[Link\]](#)
- Enhance Peptide Manufacturing Using Backbone N Protecting Groups - YouTube. YouTube. [\[Link\]](#)
- Solvent effects on beta protein toxicity in vivo - PubMed - NIH. National Center for Biotechnology Information. [\[Link\]](#)
- Amino Acid-Protecting Groups | Chemical Reviews - ACS Publications. ACS Publications. [\[Link\]](#)
- (PDF) Side reactions in peptide synthesis: An overview - ResearchGate. ResearchGate. [\[Link\]](#)
- A Theoretical Study of  $\beta$ -Amino Acid Conformational Energies and Solvent Effect - SCIRP. Scientific Research Publishing. [\[Link\]](#)
- Discovery and characterization of cyclic peptides selective for the C-terminal bromodomains of BET family proteins | bioRxiv. bioRxiv. [\[Link\]](#)

### Need Custom Synthesis?

BenchChem offers custom synthesis for rare earth carbides and specific isotopic labeling.

Email: [info@benchchem.com](mailto:info@benchchem.com) or [Request Quote Online](#).

## Sources

- [1. peptidechemistry.org \[peptidechemistry.org\]](https://peptidechemistry.org)
- [2. peptidechemistry.org \[peptidechemistry.org\]](https://peptidechemistry.org)
- [3. pubs.acs.org \[pubs.acs.org\]](https://pubs.acs.org)
- [4. peptide.com \[peptide.com\]](https://peptide.com)
- [5. Head-to-Tail Cyclization for Cyclic Peptide Synthesis - Creative Peptides \[creative-peptides.com\]](https://creative-peptides.com)
- [6. pdf.benchchem.com \[pdf.benchchem.com\]](https://pdf.benchchem.com)
- [7. bachem.com \[bachem.com\]](https://bachem.com)
- [8. bocsci.com \[bocsci.com\]](https://bocsci.com)
- [9. pubs.acs.org \[pubs.acs.org\]](https://pubs.acs.org)
- [10. Thermodynamic Stability of  \$\beta\$ -Peptide Helices and the Role of Cyclic Residues - PMC \[pmc.ncbi.nlm.nih.gov\]](https://pmc.ncbi.nlm.nih.gov)
- [11. scirp.org \[scirp.org\]](https://scirp.org)
- [12. Enhancing Peptide Cyclization: Unveiling the Key Roles of Coupling Reagents and Heat for Optimal Results - PubMed \[pubmed.ncbi.nlm.nih.gov\]](https://pubmed.ncbi.nlm.nih.gov)
- [13. support.proteinmetrics.com \[support.proteinmetrics.com\]](https://support.proteinmetrics.com)
- [14. Software-aided detection and structural characterization of cyclic peptide metabolites in biological matrix by high-resolution mass spectrometry - PMC \[pmc.ncbi.nlm.nih.gov\]](https://pmc.ncbi.nlm.nih.gov)
- [15. sciex.com \[sciex.com\]](https://sciex.com)
- To cite this document: BenchChem. [Technical Support Center: Troubleshooting Cyclization in  $\beta$ -Peptide Synthesis]. BenchChem, [2026]. [Online PDF]. Available at: [\[https://www.benchchem.com/product/b2883986/docs#technical-support-center-troubleshooting-cyclization-in-peptide-synthesis\]](https://www.benchchem.com/product/b2883986/docs#technical-support-center-troubleshooting-cyclization-in-peptide-synthesis)

---

### Disclaimer & Data Validity:

The information provided in this document is for Research Use Only (RUO) and is strictly not intended for diagnostic or therapeutic procedures. While BenchChem strives to provide accurate protocols, we make no warranties, express or implied, regarding the fitness of this product for every specific experimental setup.

**Technical Support:** The protocols provided are for reference purposes. Unsure if this reagent suits your experiment?

**Need Industrial/Bulk Grade?** [Request Custom Synthesis Quote](#)

## BenchChem

Our mission is to be the trusted global source of essential and advanced chemicals, empowering scientists and researchers to drive progress in science and industry.

### Contact

Address: 3281 E Guasti Rd  
Ontario, CA 91761, United States  
Phone: (601) 213-4426  
Email: [info@benchchem.com](mailto:info@benchchem.com)

[Contact our Ph.D. Support Team for a compatibility check](#)