

# In Vitro Characterization of DS-8895a: A Technical Guide

**Author:** BenchChem Technical Support Team. **Date:** April 2026

## Compound of Interest

Compound Name:	DS-8895
CAS No.:	1211532-85-2
Cat. No.:	B2882344

[Get Quote](#)

For Researchers, Scientists, and Drug Development Professionals

## Abstract

**DS-8895a** is a humanized, afucosylated monoclonal antibody targeting the Ephrin type-A receptor 2 (EphA2), a receptor tyrosine kinase overexpressed in a wide array of solid tumors and associated with poor prognosis.<sup>[1][2][3][4][5]</sup> This document provides a comprehensive overview of the in vitro characterization of **DS-8895a**, detailing its mechanism of action, binding properties, and functional activity. The information presented is intended to serve as a technical guide for researchers and professionals in the field of oncology drug development.

## Introduction

EphA2 is a key player in various oncogenic processes, and its expression is often upregulated through the Ras-extracellular signal-regulated kinase (ERK) signaling pathway.<sup>[1]</sup> **DS-8895a** is engineered to specifically target EphA2, including both its full-length and truncated forms, which are prevalent on the surface of tumor cells.<sup>[1][3][4]</sup> A critical feature of **DS-8895a** is its afucosylation, a modification that significantly enhances its binding affinity to FcγRIIIa on immune effector cells, leading to potent antibody-dependent cellular cytotoxicity (ADCC).<sup>[1][6]</sup>

## Mechanism of Action

The primary mechanism of action of **DS-8895a** is the induction of a powerful ADCC response against EphA2-expressing tumor cells.[1][3][4] Upon binding to EphA2 on the cancer cell surface, the Fc region of **DS-8895a** is recognized by Fcγ receptors on natural killer (NK) cells and other immune effector cells, triggering the release of cytotoxic granules and leading to tumor cell lysis.[1] In vitro studies have demonstrated that **DS-8895a** does not possess complement-dependent cytotoxicity (CDC) or agonistic activity towards EphA2 and only weakly inhibits ephrin-A1-mediated phosphorylation of its target.[6]

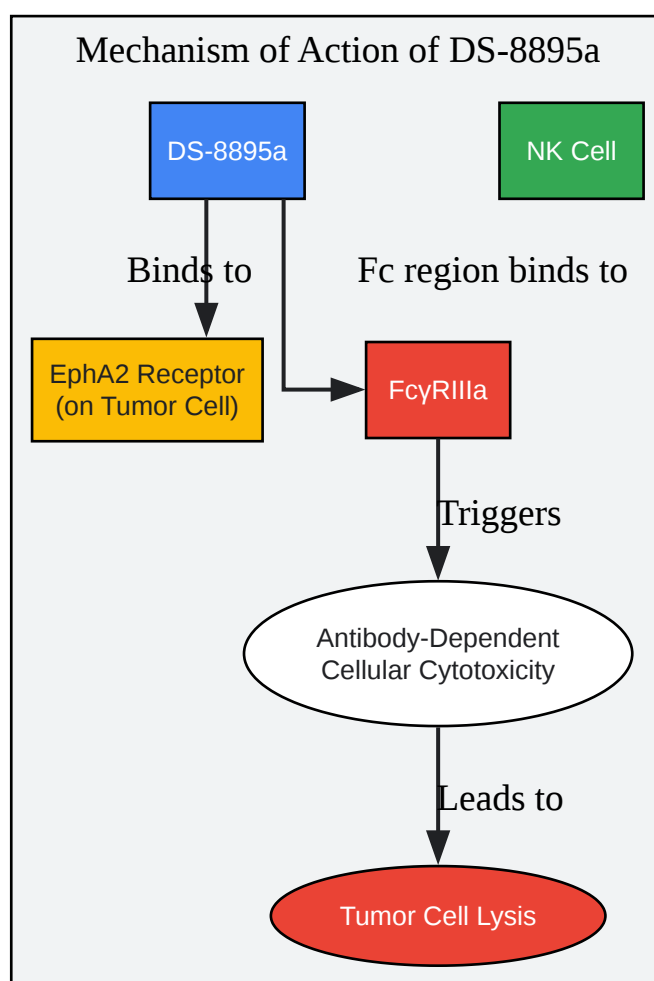

[Click to download full resolution via product page](#)

Mechanism of Action of **DS-8895a**.

## Quantitative Data

The in vitro binding characteristics of **DS-8895a** have been quantified to determine its affinity for the EphA2 receptor. The following table summarizes the key binding parameters obtained from these studies.

Parameter	Value	Cell Line	Method	Reference
Apparent Association Constant (K <sub>a</sub> )	2.14 x 10 <sup>8</sup> M <sup>-1</sup>	MDA-MB-231	Lindmo Assay	[7]
Apparent Association Constant (K <sub>a</sub> )	2.10 x 10 <sup>8</sup> M <sup>-1</sup>	MDA-MB-231	Lindmo Assay	[7]
Antibody Binding Sites per Cell	~60,000	MDA-MB-231	Scatchard Analysis	[7]
Antibody Binding Sites per Cell	~40,000	MDA-MB-231	Scatchard Analysis	[7]

## Experimental Protocols

### Cell Lines and Culture

- MDA-MB-231: Human breast adenocarcinoma cell line, positive for EphA2 expression.[1]
- SNU-16: Human gastric carcinoma cell line, positive for EphA2 expression.[1]
- CT26.WT: Mouse colon carcinoma cell line, used for transient transfection with human EphA2.[1]

Cells were cultured in appropriate media supplemented with fetal bovine serum and antibiotics, and maintained in a humidified incubator at 37°C with 5% CO<sub>2</sub>.

### Flow Cytometry for EphA2 Binding

This protocol was used to confirm the binding of **DS-8895a** to human EphA2.

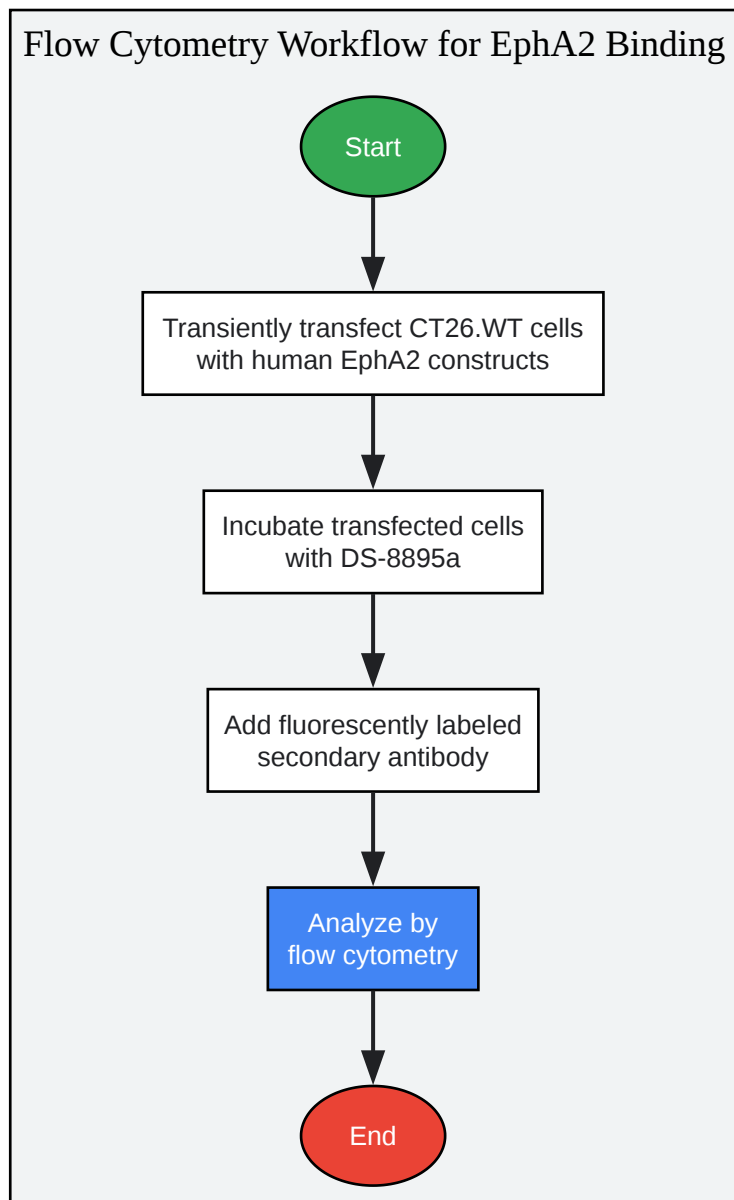

[Click to download full resolution via product page](#)

#### Flow Cytometry Workflow for EphA2 Binding.

- Cell Preparation: CT26.WT cells were transiently transfected with plasmids encoding wild-type or truncated human EphA2.[1]
- Antibody Incubation: Transfected cells were harvested and incubated with **DS-8895a**.
- Secondary Antibody Staining: After washing, cells were incubated with a fluorescently labeled secondary antibody that recognizes human IgG.

- Flow Cytometric Analysis: The fluorescence intensity of the cells was measured using a flow cytometer to determine the binding of **DS-8895a**.

## Antibody-Dependent Cellular Cytotoxicity (ADCC) Assay

This assay was performed to evaluate the enhanced ADCC activity of the afucosylated **DS-8895a**.

- Target Cell Preparation: EphA2-positive MDA-MB-231 cells were used as target cells.[1]
- Effector Cell Preparation: Human peripheral blood mononuclear cells (PBMCs) were isolated from healthy donors to be used as effector cells.[1]
- Assay Setup: Target cells were incubated with varying concentrations of **DS-8895a** or a fucose-containing parent antibody.
- Co-culture: Effector cells were then added to the antibody-treated target cells at a specific effector-to-target ratio.
- Cytotoxicity Measurement: After incubation, the extent of target cell lysis was determined by measuring the release of a pre-loaded fluorescent dye or an intracellular enzyme (e.g., lactate dehydrogenase).

## Radioligand Binding Assays (Lindmo and Scatchard Analyses)

These assays were conducted to determine the binding affinity and the number of receptor sites on target cells.

- Radiolabeling: **DS-8895a** was labeled with a radioisotope (e.g., <sup>125</sup>I or <sup>111</sup>In).[7]
- Lindmo Assay (Immunoreactivity):
  - A fixed amount of radiolabeled **DS-8895a** was incubated with increasing concentrations of EphA2-positive MDA-MB-231 cells.[7]
  - The percentage of bound antibody was plotted against the reciprocal of the cell concentration.

- The y-intercept of the resulting linear regression represents the immunoreactive fraction of the antibody.
- Scatchard Analysis (Binding Affinity and Receptor Number):
  - A fixed number of MDA-MB-231 cells were incubated with increasing concentrations of radiolabeled **DS-8895a**.[\[7\]](#)
  - Non-specific binding was determined in the presence of a large excess of unlabeled antibody.
  - The ratio of bound to free radioligand was plotted against the concentration of bound radioligand.
  - The dissociation constant ( $K_d$ ) and the maximum number of binding sites ( $B_{max}$ ) were calculated from the slope and x-intercept of the Scatchard plot, respectively.

## Signaling Pathways

**DS-8895a** targets the EphA2 receptor, which is involved in complex signaling pathways that can have dual roles in cancer, acting as both a tumor suppressor and a promoter of malignancy. The oncogenic signaling of EphA2 is often ligand-independent and can be activated by the Ras-ERK pathway.[\[1\]](#)

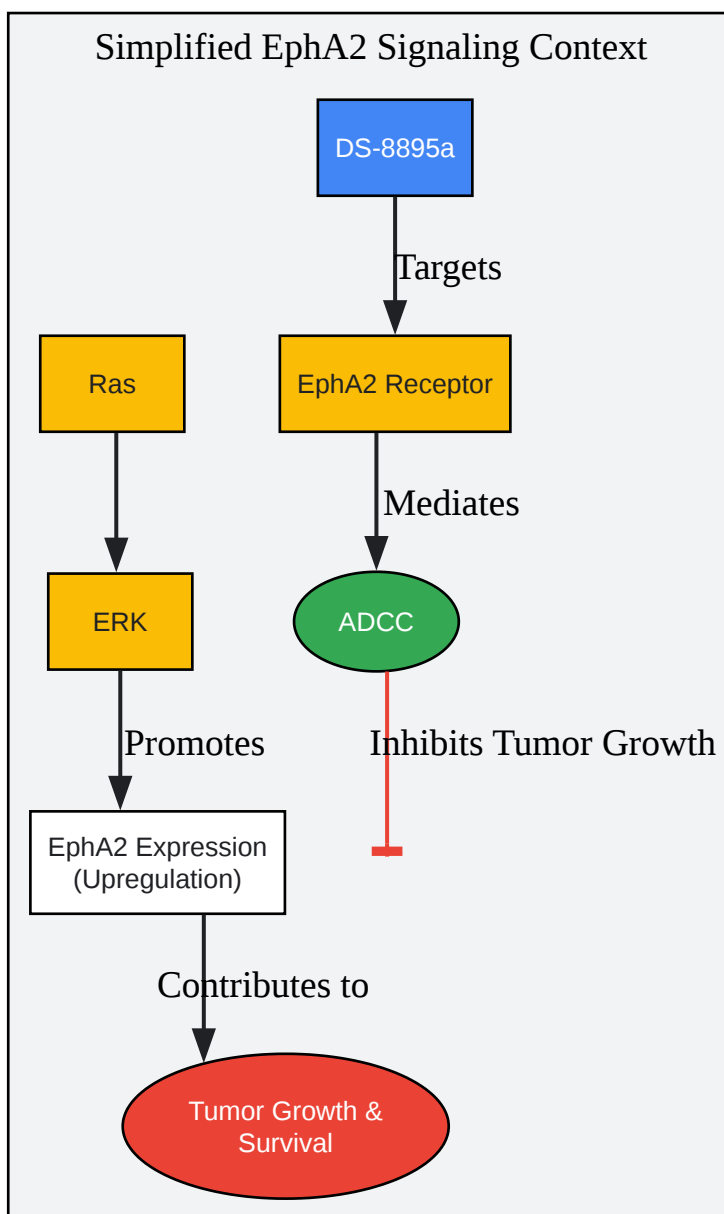

[Click to download full resolution via product page](#)

Simplified EphA2 Signaling Context.

## Conclusion

The in vitro characterization of **DS-8895a** demonstrates its high-affinity binding to the EphA2 receptor and, most importantly, its potent anti-tumor activity mediated by enhanced ADCC. These preclinical findings established the foundation for the clinical development of **DS-8895a** as a potential therapeutic agent for patients with EphA2-positive solid tumors. However, it is

important to note that despite promising preclinical data, the clinical development of **DS-8895a** was halted due to limited therapeutic efficacy and low tumor uptake observed in a Phase 1 trial. [8][9] This highlights the critical importance of robust biodistribution studies in the early phases of drug development.[8][9]

### Need Custom Synthesis?

BenchChem offers custom synthesis for rare earth carbides and specific isotopic labeling.

Email: [info@benchchem.com](mailto:info@benchchem.com) or [Request Quote Online](#).

## References

- 1. Novel anti-EPHA2 antibody, DS-8895a for cancer treatment - PMC [[pmc.ncbi.nlm.nih.gov](https://pubmed.ncbi.nlm.nih.gov)]
- 2. Facebook [[cancer.gov](https://www.facebook.com/cancer.gov)]
- 3. citeab.com [[citeab.com](https://citeab.com)]
- 4. Novel anti-EPHA2 antibody, DS-8895a for cancer treatment - PubMed [[pubmed.ncbi.nlm.nih.gov](https://pubmed.ncbi.nlm.nih.gov)]
- 5. Safety, tolerability, pharmacokinetics, and pharmacodynamics of the afucosylated, humanized anti-EPHA2 antibody DS-8895a: a first-in-human phase I dose escalation and dose expansion study in patients with advanced solid tumors - PMC [[pmc.ncbi.nlm.nih.gov](https://pubmed.ncbi.nlm.nih.gov)]
- 6. [jitc.bmj.com](https://jitc.bmj.com) [[jitc.bmj.com](https://jitc.bmj.com)]
- 7. [jnm.snmjournals.org](https://jnm.snmjournals.org) [[jnm.snmjournals.org](https://jnm.snmjournals.org)]
- 8. A phase 1 safety and bioimaging trial of antibody DS-8895a against EphA2 in patients with advanced or metastatic EphA2 positive cancers - PubMed [[pubmed.ncbi.nlm.nih.gov](https://pubmed.ncbi.nlm.nih.gov)]
- 9. [researchgate.net](https://www.researchgate.net) [[researchgate.net](https://www.researchgate.net)]
- To cite this document: BenchChem. [In Vitro Characterization of DS-8895a: A Technical Guide]. BenchChem, [2026]. [Online PDF]. Available at: [<https://www.benchchem.com/product/b2882344/docs#in-vitro-characterization-of-ds-8895a-a-technical-guide>]

---

### Disclaimer & Data Validity:

The information provided in this document is for Research Use Only (RUO) and is strictly not intended for diagnostic or therapeutic procedures. While BenchChem strives to provide accurate protocols, we make no warranties, express or implied, regarding the fitness of this product for every specific experimental setup.

**Technical Support:** The protocols provided are for reference purposes. Unsure if this reagent suits your experiment?

**Need Industrial/Bulk Grade?** [Request Custom Synthesis Quote](#)

## BenchChem

Our mission is to be the trusted global source of essential and advanced chemicals, empowering scientists and researchers to drive progress in science and industry.

### Contact

Address: 3281 E Guasti Rd  
Ontario, CA 91761, United States  
Phone: (601) 213-4426  
Email: [info@benchchem.com](mailto:info@benchchem.com)

[Contact our Ph.D. Support Team for a compatibility check](#)