

# N-(4-methoxybenzyl)-1-phenylethanamine: A Strategic Chiral Building Block

**Author:** BenchChem Technical Support Team. **Date:** May 2026

## Compound of Interest

**Compound Name:** *N*-(4-methoxybenzyl)-1-phenylethanamine  
**CAS No.:** 356537-04-7  
**Cat. No.:** B2878006

[Get Quote](#)

Technical Guide for Asymmetric Synthesis & Drug Development

## Executive Summary

**N-(4-methoxybenzyl)-1-phenylethanamine** (also referred to as N-PMB- $\alpha$ -methylbenzylamine) represents a high-value "hybrid" chiral auxiliary. It combines the rigorous stereocontrol of the classic 1-phenylethylamine moiety with the orthogonal lability of the p-methoxybenzyl (PMB) protecting group.

Unlike its N-benzyl analog (a staple in the Davies and Simpkins protocols), the PMB variant allows for oxidative deprotection. This critical distinction enables the synthesis of chiral amines containing alkenes, benzyl ethers, or sulfur functionalities that would otherwise be destroyed under the hydrogenolytic conditions required to remove a standard benzyl group.

This guide details the synthesis, physical properties, and application of this auxiliary, focusing on its role as a Homochiral Ammonia Equivalent in asymmetric conjugate additions.<sup>[1]</sup>

## Part 1: Structural Significance & Synthesis

### The "Dual-Key" Architecture

The molecule derives its utility from two distinct structural domains:

- The Chiral Controller (1-Phenylethyl group): Provides the steric bulk and rigid conformation necessary to differentiate enantiotopic faces of prochiral substrates (e.g., in enolate alkylation or conjugate addition).
- The Safety Valve (PMB group): An electron-rich aromatic ring that serves as a "tunable" protecting group. It is stable to basic and nucleophilic conditions but cleaves readily under specific oxidative or acidic conditions.

### Synthesis Protocol: Reductive Amination

While the compound can be synthesized via nucleophilic substitution, reductive amination is the industry standard due to higher yields and the avoidance of over-alkylation.

Reaction Logic: We utilize (S)-(-)-1-phenylethylamine and 4-methoxybenzaldehyde. The aldehyde is chosen over the ketone (acetophenone) for its superior electrophilicity, ensuring rapid imine formation and minimizing racemization risks.

Step-by-Step Protocol:

- Imine Formation:
  - Charge a reactor with (S)-1-phenylethylamine (1.0 equiv) and anhydrous MeOH (5 mL/mmol).
  - Add 4-methoxybenzaldehyde (1.05 equiv) dropwise at 0°C.
  - Observation: The solution typically turns yellow/orange, indicating imine formation.
  - Stir at 25°C for 2–4 hours. (Monitoring: <sup>1</sup>H NMR shows disappearance of aldehyde -CHO peak at ~10 ppm).
- Reduction:

- Cool the mixture to 0°C.
- Add NaBH<sub>4</sub> (1.5 equiv) portion-wise. Caution: Hydrogen gas evolution.
- Stir for 12 hours, allowing the mixture to warm to room temperature.
- Workup & Purification:
  - Quench with saturated NH<sub>4</sub>Cl solution.
  - Extract with CH<sub>2</sub>Cl<sub>2</sub> (x3). Wash combined organics with brine, dry over Na<sub>2</sub>SO<sub>4</sub>.<sup>[2]</sup>
  - Concentrate in vacuo.
  - Purification: Flash chromatography (SiO<sub>2</sub>, Hexane/EtOAc 80:20).

Physical Data (Typical for (S)-isomer):

- Appearance: Colorless to pale yellow oil.
- Optical Rotation:

(c=1.0, CHCl<sub>3</sub>) (Note: Sign depends on specific enantiomer of starting amine).

- <sup>1</sup>H NMR (CDCl<sub>3</sub>, 400 MHz):

7.35-7.20 (m, 5H), 7.25 (d, 2H), 6.85 (d, 2H), 3.79 (s, 3H, OMe), 3.75 (q, 1H, CH-Me), 3.60 (dd, 2H, CH<sub>2</sub>-Ar), 1.35 (d, 3H, Me).

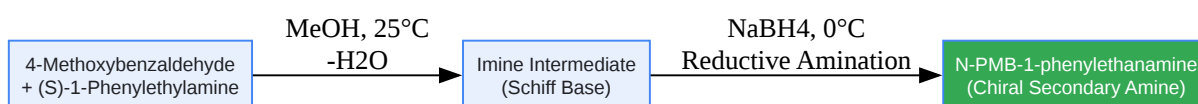

[Click to download full resolution via product page](#)

Caption: Synthesis via reductive amination ensures retention of chirality from the amine starting material.

## Part 2: Application - Asymmetric Conjugate Addition (The Davies Protocol)

The primary application of this building block is in the Davies Asymmetric Conjugate Addition. Here, the amine is converted to a chiral lithium amide, which attacks

-unsaturated esters with high facial selectivity.

### The Workflow

- Lithiation: The secondary amine is treated with n-BuLi to form the chiral lithium amide.
- Conjugate Addition: The lithium amide attacks the  
-position of an unsaturated ester (e.g., tert-butyl crotonate).
- Enolate Trapping: The resulting enolate can be quenched with a proton (to give  
-amino acids) or an electrophile (to create  
-disubstituted centers).

### Why PMB? (The Critical Advantage)

In the standard Davies protocol using N-benzyl-1-phenylethylamine, the final step requires hydrogenolysis (Pd/C, H<sub>2</sub>) to remove the chiral auxiliary.

- Problem: If your target molecule contains an alkene (e.g., R = Allyl) or a benzyl ether, hydrogenolysis will destroy them.
- Solution: The N-PMB variant allows you to use CAN (Ceric Ammonium Nitrate) or DDQ for deprotection, leaving alkenes and other benzyl groups intact.

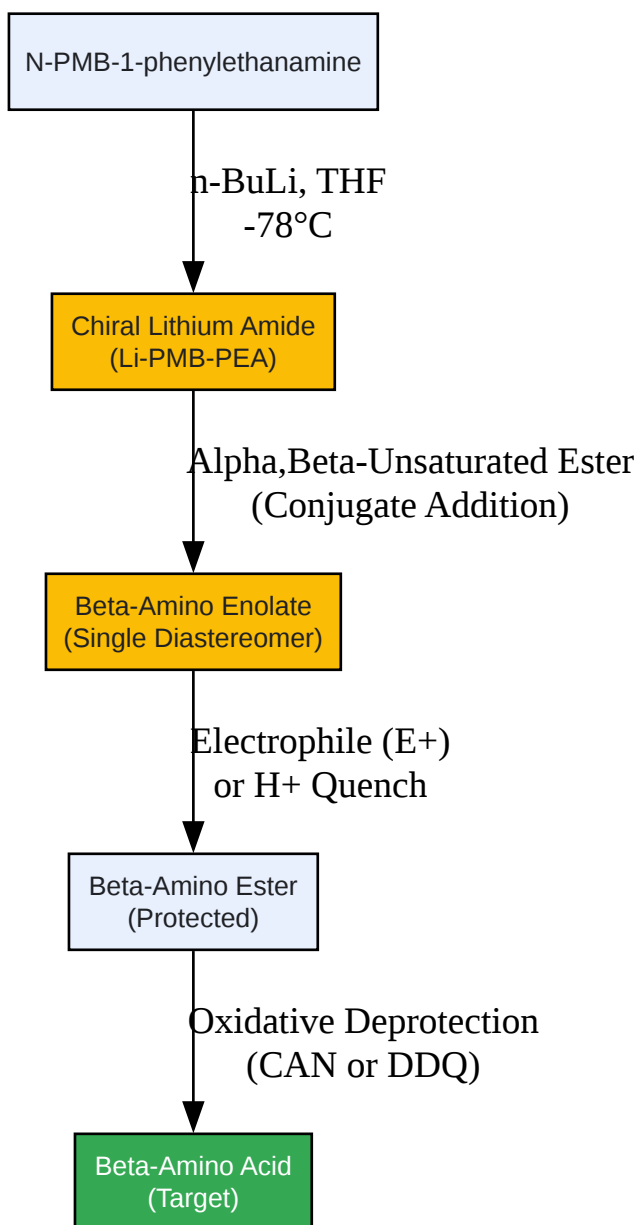

[Click to download full resolution via product page](#)

Caption: The Davies protocol utilizing the PMB-variant allows for oxidative cleavage, preserving sensitive functionality.

## Part 3: Strategic Deprotection Protocols

This section details the specific methodologies to remove the auxiliary. The choice of method depends on the substrate stability.

## Method A: Oxidative Cleavage (CAN)

Best for: Substrates containing alkenes, alkynes, or benzyl ethers.

Protocol:

- Dissolve the protected amine (1.0 equiv) in MeCN/H<sub>2</sub>O (4:1).
- Cool to 0°C.
- Add Ceric Ammonium Nitrate (CAN) (3.0–4.0 equiv) portion-wise.
  - Mechanism:<sup>[2]</sup><sup>[3]</sup><sup>[4]</sup> CAN oxidizes the electron-rich PMB ring to a radical cation, which is then trapped by water, fragmenting into 4-methoxybenzaldehyde and the free amine.
- Stir for 30–60 minutes.
- Workup: Dilute with water, neutralize with NaHCO<sub>3</sub>, and extract.
- Note: This removes the PMB group.<sup>[3]</sup><sup>[5]</sup> The 1-phenylethyl group may require a second step (hydrogenolysis) if it was not removed simultaneously, or if the goal is to swap protecting groups. However, usually, this auxiliary is designed so that BOTH groups are removed or the PMB is removed selectively.
  - Correction: In the Davies context, usually both N-benzyl and N-phenylethyl groups are removed by hydrogenolysis. With the PMB variant, CAN removes the PMB selectively, leaving the N-(1-phenylethyl) secondary amine, or if conditions are rigorous, it can facilitate further breakdown.
  - Refined Strategy: To remove the entire auxiliary (both PMB and Phenylethyl), a two-step sequence is often used if hydrogenolysis is forbidden:
    1. CAN/DDQ removes PMB  
  
Secondary Amine.
    2. Sol dissolving metal or specific oxidative methods remove the phenylethyl group (though phenylethyl is robust).

- Most common use:<sup>[1]</sup><sup>[6]</sup> Remove PMB to reveal the secondary amine for further functionalization, then remove the phenylethyl group later via hydrogenolysis once the sensitive alkene has been transformed.

## Method B: Acidic Hydride Transfer

Best for: Substrates sensitive to oxidation but stable to acid.

Protocol:

- Dissolve substrate in Trifluoroacetic Acid (TFA).
- Add Triethylsilane (Et<sub>3</sub>SiH) (2-3 equiv).
- Reflux or heat to 60°C.
  - Mechanism:<sup>[2]</sup><sup>[3]</sup><sup>[4]</sup> Protonation of the PMB ether/amine followed by hydride delivery from silane.
  - Result: Clean removal of PMB as 4-methoxytoluene.

## Comparison Table: Deprotection Strategies

Method	Reagents	Mechanism	Compatible With	Incompatible With
Oxidative	CAN or DDQ	Single Electron Transfer (SET)	Alkenes, Alkynes, Benzyl Ethers	Electron-rich aromatics, free thiols
Hydrogenolysis	H <sub>2</sub> / Pd-C	Catalytic Hydrogenation	Saturated systems, Fluorides	Alkenes, Alkynes, Benzyl Ethers, Sulfur
Acidic Hydride	TFA / Et <sub>3</sub> SiH	Carbocation reduction	Alkenes (mostly), Benzyl ethers	Acid-sensitive acetals/protectin g groups

## References

- Davies, S. G., et al. "Lithium Amides as Homochiral Ammonia Equivalents for Conjugate Additions to  $\alpha$ -Unsaturated Esters." [6] *Organic Syntheses*, 2010, 87, 143. [1][6] [Link](#)
- Davies, S. G., et al. "Discussion Addendum for: Lithium Amides as Homochiral Ammonia Equivalents." *Organic Syntheses*, 2019, 96, 53-65. [6] [Link](#)
  - Key Citation: Explicitly discusses the N-PMB analog and its deprotection with CAN.
- Bull, S. D., Davies, S. G., et al. "Conjugate addition of lithium (R)-N-phenyl-N-( $\alpha$ -methylbenzyl)amide." *Journal of the Chemical Society, Perkin Transactions 1*, 2001.
- Overman, L. E. "Oxidative Cleavage of p-Methoxybenzyl Ethers." *Journal of the American Chemical Society*. (General reference for PMB cleavage mechanics).

#### Need Custom Synthesis?

BenchChem offers custom synthesis for rare earth carbides and specific isotopic labeling.

Email: [info@benchchem.com](mailto:info@benchchem.com) or [Request Quote Online](#).

## Sources

- 1. [Organic Syntheses Procedure \[orgsyn.org\]](#)
- 2. [researchgate.net \[researchgate.net\]](#)
- 3. [total-synthesis.com \[total-synthesis.com\]](#)
- 4. A Facile One-Pot Process for the Formation of Hindered Tertiary Amines - PMC [[pmc.ncbi.nlm.nih.gov](#)]
- 5. WO2008145620A1 - Process for the deprotection of aryl group protected amines employing oxidases - Google Patents [[patents.google.com](#)]
- 6. [orgsyn.org \[orgsyn.org\]](#)
- To cite this document: BenchChem. [N-(4-methoxybenzyl)-1-phenylethanamine: A Strategic Chiral Building Block]. BenchChem, [2026]. [Online PDF]. Available at: [<https://www.benchchem.com/product/b2878006/docs#n-4-methoxybenzyl-1-phenylethanamine-a-strategic-chiral-building-block>]

**Disclaimer & Data Validity:**

The information provided in this document is for Research Use Only (RUO) and is strictly not intended for diagnostic or therapeutic procedures. While BenchChem strives to provide accurate protocols, we make no warranties, express or implied, regarding the fitness of this product for every specific experimental setup.

**Technical Support:** The protocols provided are for reference purposes. Unsure if this reagent suits your experiment?

**Need Industrial/Bulk Grade?** [Request Custom Synthesis Quote](#)

## BenchChem

Our mission is to be the trusted global source of essential and advanced chemicals, empowering scientists and researchers to drive progress in science and industry.

### Contact

Address: 3281 E Guasti Rd  
Ontario, CA 91761, United States  
Phone: (601) 213-4426  
Email: [info@benchchem.com](mailto:info@benchchem.com)

[Contact our Ph.D. Support Team for a compatibility check](#)