

Application Note: High-Precision In Vitro Profiling of 1-(3-Hydroxyphenyl)-3-phenylurea

Author: BenchChem Technical Support Team. **Date:** May 2026

Compound of Interest

Compound Name: 3-(3-Hydroxyphenyl)-1-phenylurea

CAS No.: 13142-80-8

Cat. No.: B2878009

[Get Quote](#)

Executive Summary & Biological Context

1-(3-Hydroxyphenyl)-3-phenylurea (also known as N-(3-hydroxyphenyl)-N'-phenylurea) represents a privileged chemical scaffold in drug discovery. Belonging to the diarylurea class, its structural motif—a urea linker flanked by aromatic rings—is foundational to several FDA-approved kinase inhibitors (e.g., Sorafenib, Regorafenib).

Mechanistic Significance:

- Kinase Inhibition (Type II): The urea moiety functions as a critical hydrogen bond donor/acceptor pair, often binding to the "Glu-out" conformation of kinases (e.g., VEGFR-2, c-MET) or occupying the hydrophobic pocket of enzymes like IDO1 (Indoleamine 2,3-dioxygenase).
- Integrated Stress Response (ISR): Specific diarylureas have been identified as activators of HRI (Heme-Regulated Inhibitor kinase), triggering eIF2 phosphorylation and halting protein synthesis under stress.^[1]

- **Cytokinin Mimicry:** In plant biology, this scaffold exhibits cytokinin-like activity, though this application note focuses on mammalian pharmacological profiling.

This guide provides rigorous dosing guidelines and protocols for evaluating the compound's antiproliferative potency and target engagement in vitro.

Physicochemical Properties & Handling[2][3]

The urea linkage and phenolic hydroxyl group create specific solubility challenges. Improper handling leads to precipitation in aqueous media, invalidating IC

data.

Property	Specification	Critical Note
Molecular Weight	228.25 g/mol	--
Solubility (Water)	Low (< 0.1 mg/mL)	Do not dissolve directly in media.
Solubility (DMSO)	High (~50 mM)	Preferred solvent for stock solutions.
Solubility (Ethanol)	Moderate	Avoid for cell assays due to volatility/toxicity.
Stability	Hydrolytically stable	Phenol group is oxidation-prone; protect from light.

Preparation of Stock Solutions

- **Standard Stock:** Prepare a 10 mM stock solution in anhydrous DMSO (dimethyl sulfoxide).
 - **Calculation:** Dissolve 2.28 mg of compound in 1.0 mL of DMSO.
- **Storage:** Aliquot into amber glass vials (avoid plastic if possible to prevent leaching) and store at -20°C. Stable for 3 months. Avoid repeated freeze-thaw cycles.
- **Quality Control:** Visually inspect for needle-like crystals before use. If precipitate is visible, sonicate at 40°C for 5 minutes.

Core Protocol A: Antiproliferative Viability Assay

Objective: Determine the IC

(half-maximal inhibitory concentration) in cancer cell lines (e.g., MCF-7, PC-3, A549).

Experimental Logic

Diarylureas often exhibit cytostatic rather than immediate cytotoxic effects. Therefore, a 72-hour incubation is recommended over 24 or 48 hours to capture growth inhibition accurately.

Materials

- Cell Lines: A549 (Lung), MCF-7 (Breast), or HUVEC (for angiogenesis models).
- Assay Reagent: CellTiter-Glo® (ATP-based) or MTT (Metabolic activity).
- Vehicle: DMSO (Final concentration must be < 0.5%).

Step-by-Step Workflow

- Cell Seeding (Day 0):
 - Seed cells at optimal density (e.g., 3,000–5,000 cells/well) in 96-well plates.
 - Volume: 90 µL per well.
 - Incubate for 24 hours to allow attachment.
- Compound Serial Dilution (Day 1):
 - Step 2a (Master Plate): In a separate V-bottom plate, prepare a 200x concentration series in 100% DMSO.
 - Top Conc: 20 mM (Final assay conc: 100 µM).
 - Dilution Factor: 1:3 serial dilution (8 points).
 - Range: 100 µM

33 μM

...

~0.04 μM .

- Step 2b (Intermediate Plate): Dilute the 200x DMSO stocks 1:10 into culture media (resulting in 20x conc, 10% DMSO).
- Step 2c (Dosing): Add 10 μL of the Intermediate Plate solution to the 90 μL of cells.
 - Final Conditions: 1x Compound, 0.5% DMSO.
- Incubation:
 - Incubate for 72 hours at 37°C, 5% CO₂.
- Readout (Day 4):
 - Add detection reagent (e.g., 100 μL CellTiter-Glo).
 - Shake for 2 minutes; incubate 10 minutes (dark).
 - Measure Luminescence (RLU).

Data Analysis

- Normalization: Normalize RLU values to Vehicle Control (0.5% DMSO) = 100% Viability and Positive Control (e.g., Staurosporine) = 0% Viability.
- Curve Fitting: Use a 4-parameter logistic regression (Hill equation).

Core Protocol B: Target Engagement (Kinase/Enzyme Inhibition)

Objective: Evaluate the compound's ability to inhibit a specific target (e.g., VEGFR2 or IDO1) or activate HRI, utilizing the urea linker's H-bonding capacity.

Experimental Logic

The 1,3-disubstituted urea motif binds to the "DFG-Asp" backbone in kinases. The 3-hydroxyl group acts as a hydrogen bond donor/acceptor mimic, probing the hydrophilic regions of the ATP-binding pocket.

Workflow Visualization

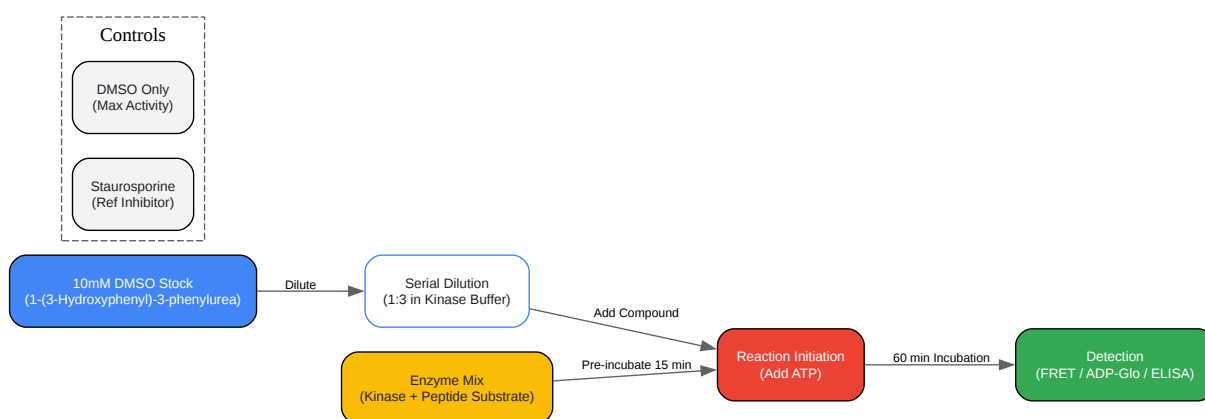

[Click to download full resolution via product page](#)

Caption: Workflow for enzymatic inhibition assay. Pre-incubation is critical for urea-based Type II inhibitors to access the allosteric pocket.

Protocol Steps

- Buffer Prep: Use a HEPES-based buffer (pH 7.5) supplemented with 10 mM MgCl₂, 1 mM DTT, and 0.01% Triton X-100 (to prevent compound aggregation).
- Pre-Incubation (Critical):

- Mix Enzyme (e.g., 5 nM VEGFR2) and Compound.
- Incubate for 15–30 minutes before adding ATP.
- Reasoning: Diarylureas are often slow-binding or allosteric inhibitors; they require time to induce the conformational change (e.g., DFG-out).
- Reaction Start: Add ATP (at K concentration) and peptide substrate.
- Termination: Stop reaction after 60 minutes and detect phosphorylation (e.g., via ADP-Glo or FRET).

Mechanistic Insight: The Urea Pharmacophore

Understanding why this molecule works is essential for interpreting data.

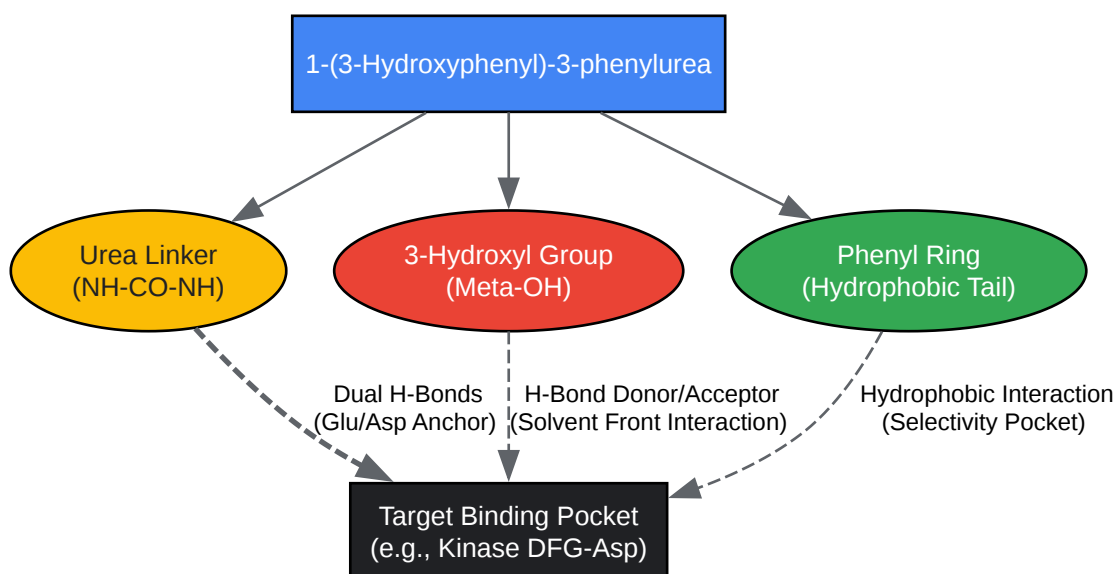

[Click to download full resolution via product page](#)

Caption: Pharmacophore mapping of the diarylurea scaffold. The urea bridge provides the primary anchoring via hydrogen bonding, while the meta-hydroxyl group probes specific polar interactions.

Troubleshooting & Optimization

Observation	Probable Cause	Corrective Action
Steep Hill Slope (> 2.0)	Compound Aggregation	Add 0.01% Triton X-100 to assay buffer; ensure DMSO < 1%.
No Inhibition (IC ₅₀ > 100µM)	Poor Solubility or Wrong Target	Verify stock clarity. Confirm target relevance (e.g., check HRI activation vs. Kinase inhibition).[2]
High Variation (Replicates)	Pipetting Error or Evaporation	Use automated liquid handling; seal plates during 72h incubation.
Yellowing of Stock	Oxidation of Phenol	Discard stock. Prepare fresh from powder and store under N ₂ or Ar gas.

References

- BenchChem. (2025). Application Notes and Protocols: Development of Phenylurea Derivatives as Anti-Cancer Therapeutics. Retrieved from
- National Center for Biotechnology Information. (2025). PubChem Compound Summary for CID 701-82-6, N-(3-Hydroxyphenyl)urea. Retrieved from
- Aktas, B. H., et al. (2020).[3] New activators of eIF2α Kinase Heme-Regulated Inhibitor (HRI) with improved biophysical properties. European Journal of Medicinal Chemistry. Retrieved from
- CymitQuimica. (2025).[4][5][6] CAS 701-82-6: N-(3-Hydroxyphenyl)urea Properties and Specifications. Retrieved from
- ResearchGate. (2025). Structure-activity relationship guided design of diaryl urea derivatives. Retrieved from

Need Custom Synthesis?

BenchChem offers custom synthesis for rare earth carbides and specific isotopic labeling.

Email: info@benchchem.com or [Request Quote Online](#).

Sources

- [1. researchgate.net \[researchgate.net\]](https://www.researchgate.net)
- [2. The eIF2-alpha kinase HRI: a potential target beyond the red blood cell - PMC \[pmc.ncbi.nlm.nih.gov\]](https://pubmed.ncbi.nlm.nih.gov)
- [3. New activators of eIF2 \$\alpha\$ Kinase Heme-Regulated Inhibitor \(HRI\) with improved biophysical properties - PubMed \[pubmed.ncbi.nlm.nih.gov\]](https://pubmed.ncbi.nlm.nih.gov)
- [4. researchgate.net \[researchgate.net\]](https://www.researchgate.net)
- [5. N,N-Diethyl-N'-\(3-\(\(\(methylamino\)carbonyl\)oxy\)phenyl\)urea | C13H19N3O3 | CID 99433 - PubChem \[pubchem.ncbi.nlm.nih.gov\]](https://pubchem.ncbi.nlm.nih.gov)
- [6. Structure–activity relationship guided design, synthesis and biological evaluation of novel diaryl urea derivatives as antiproliferative agents - PMC \[pmc.ncbi.nlm.nih.gov\]](https://pubmed.ncbi.nlm.nih.gov)
- To cite this document: BenchChem. [Application Note: High-Precision In Vitro Profiling of 1-(3-Hydroxyphenyl)-3-phenylurea]. BenchChem, [2026]. [Online PDF]. Available at: [\[https://www.benchchem.com/product/b2878009/docs#application-note-high-precision-in-vitro-profiling-of-1-3-hydroxyphenyl-3-phenylurea\]](https://www.benchchem.com/product/b2878009/docs#application-note-high-precision-in-vitro-profiling-of-1-3-hydroxyphenyl-3-phenylurea)

Disclaimer & Data Validity:

The information provided in this document is for Research Use Only (RUO) and is strictly not intended for diagnostic or therapeutic procedures. While BenchChem strives to provide accurate protocols, we make no warranties, express or implied, regarding the fitness of this product for every specific experimental setup.

Technical Support: The protocols provided are for reference purposes. Unsure if this reagent suits your experiment?

Need Industrial/Bulk Grade? [Request Custom Synthesis Quote](#)

BenchChem

Our mission is to be the trusted global source of essential and advanced chemicals, empowering scientists and researchers to drive progress in science and industry.

Contact

Address: 3281 E Guasti Rd

Ontario, CA 91761, United States

Phone: (601) 213-4426

Email: info@benchchem.com

[Contact our Ph.D. Support Team for a compatibility check](#)