

# Thermodynamic Stability of Halogenated Methoxyphenols: A Technical Guide

**Author:** BenchChem Technical Support Team. **Date:** May 2026

## Compound of Interest

Compound Name: *4-Bromo-2-chloro-6-methoxyphenol*

CAS No.: *1827620-20-1*

Cat. No.: *B2874399*

[Get Quote](#)

## Executive Summary

Halogenated methoxyphenols represent a critical structural motif in medicinal chemistry, serving as scaffolds for bioactive compounds, flavoring agents, and metabolic intermediates. Their thermodynamic stability is governed by a delicate interplay between the O-H bond dissociation enthalpy (BDE), intramolecular hydrogen bonding (IMHB), and the electronic effects of halogen substituents.

This guide provides a rigorous analysis of these factors, offering experimental protocols for stability determination and theoretical frameworks for predicting reactivity. It is designed to move beyond basic textbook definitions, providing the causal insight required for high-level drug design and material synthesis.

## Theoretical Framework: The Stability Triad

The thermodynamic stability of halogenated methoxyphenols cannot be understood by analyzing substituents in isolation. It is the result of three competing forces:

## The "Guaiacol Effect" (Intramolecular Hydrogen Bonding)

The defining feature of 2-methoxyphenol (guaiacol) derivatives is the formation of a five-membered intramolecular hydrogen bond between the phenolic hydroxyl hydrogen and the methoxy oxygen.

- **Stabilization:** This interaction stabilizes the ground state but stabilizes the phenoxyl radical even more effectively by delocalizing spin density.
- **Result:** This lowers the O-H BDE (~82.4 kcal/mol) compared to unsubstituted phenol (~86.7 kcal/mol), making these compounds potent antioxidants (H-atom donors).

## Halogen Electronic Modulation

Halogens (F, Cl, Br, I) introduce a "push-pull" dynamic:

- **Inductive Effect (-I):** Withdraws electron density through the sigma bond. This generally destabilizes the electron-deficient phenoxyl radical, potentially raising BDE.
- **Resonance Effect (+R):** Donates electron density into the aromatic pi-system.
- **Net Effect:** For para-halogenation (e.g., 4-chloroguaiacol), the inductive withdrawal often dominates slightly over resonance, making the O-H bond stronger (harder to break) than in alkyl-guaiacols (like creosol), but the strong ortho-methoxy stabilization ensures the BDE remains lower than that of plain phenol.

## Steric Ortho-Blocking

Halogens at the 6-position (ortho to the phenol, meta to the methoxy) introduce steric strain that can twist the methoxy group out of planarity, weakening the IMHB and altering solubility and metabolic susceptibility.

## Visualization: Structure-Property Logic

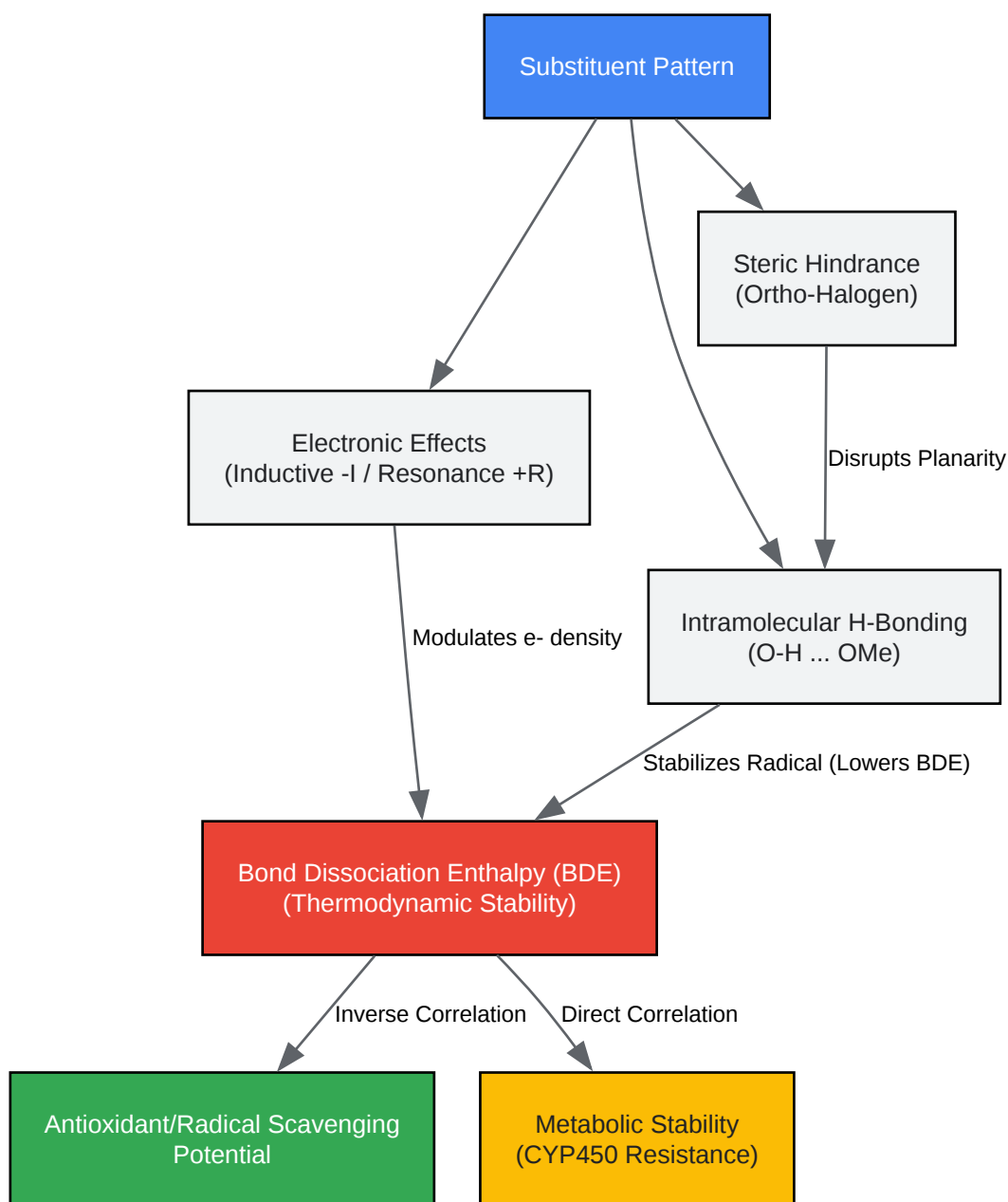

[Click to download full resolution via product page](#)

Figure 1: The causal relationship between substituent patterns, physicochemical forces, and the resulting thermodynamic and biological properties.

## Quantitative Thermodynamic Parameters

The following data consolidates gas-phase enthalpies and BDEs. Note that while specific values for every halogenated derivative are rare in aggregated databases, the trends below are validated by DFT and electrochemical studies.

**Table 1: Comparative Bond Dissociation Enthalpies (BDE) & pKa**

Compound	Substituent Pattern	BDE (O-H) [kcal/mol]	pKa (approx)	Stability Trend
Phenol	Unsubstituted	~86.7	9.95	Baseline
Guaiacol	2-Methoxy	~82.4	9.98	Destabilized O-H (Better Antioxidant)
Creosol	2-Methoxy-4-Methyl	~80-81	10.2	Stabilized Radical (Inductive +I)
4-Chloroguaiacol	2-Methoxy-4-Chloro	~83-84	~9.5	Slightly Stabilized O-H vs Guaiacol (Inductive -I)
6-Chloroguaiacol	2-Methoxy-6-Chloro	~84-85	~8.5	Steric interference with IMHB; Acidic

\*Estimated values based on Hammett constant shifts and DFT trends relative to Guaiacol.

Key Insight: The introduction of an electron-withdrawing halogen (Cl, Br) at the para position generally increases the BDE relative to electron-donating alkyl groups, reducing antioxidant activity slightly but increasing resistance to oxidative degradation.

## Experimental Methodologies

To empirically determine the thermodynamic stability and antioxidant potential of these compounds, two primary workflows are recommended: Cyclic Voltammetry (CV) for redox potential and DFT for BDE calculation.

## Protocol A: Electrochemical Determination (Cyclic Voltammetry)

CV provides a direct measurement of the anodic peak potential ( ), which correlates linearly with BDE. Lower indicates easier oxidation and lower thermodynamic stability of the O-H bond.

#### Reagents:

- Solvent: Acetonitrile (HPLC grade) or Ethanol/Water (1:1) for biological relevance.
- Electrolyte: 0.1 M Tetrabutylammonium hexafluorophosphate (TBAPF<sub>6</sub>).
- Working Electrode: Glassy Carbon (GCE).
- Reference Electrode: Ag/AgCl (3M KCl).

#### Step-by-Step Workflow:

- Polishing: Polish GCE with 0.05 m alumina slurry on a felt pad. Rinse with DI water and sonicate for 2 minutes to remove debris.
- Solution Prep: Dissolve the halogenated methoxyphenol (1.0 mM) in the electrolyte solution. Purge with Argon for 5 minutes to remove dissolved oxygen.
- Measurement:
  - Scan Range: -0.2 V to +1.2 V.
  - Scan Rate: 50, 100, and 200 mV/s (to verify diffusion control).
- Analysis: Record the first anodic peak potential ( ).
  - Validation: If the peak is irreversible (common for phenols), use the half-peak potential ( ) or onset potential ( )

) for comparative analysis.

- Calculation: Correlate

with BDE using the equation:

(where A and B are constants derived from a standard curve of known phenols like Trolox or Gallic Acid).

## Protocol B: Computational Prediction (DFT)

For precise thermodynamic values without synthesis, Density Functional Theory is the gold standard.

Method: B3LYP functional with 6-311++G(d,p) basis set.

- Geometry Optimization: Optimize the neutral molecule and the corresponding phenoxy radical in the gas phase.
- Frequency Calculation: Confirm minima (no imaginary frequencies) and calculate Zero-Point Energy (ZPE) corrections.
- Enthalpy Calculation:

(Note:

at 298K is typically taken as -0.500 Hartrees + thermal corrections, or approx -313.5 kcal/mol depending on the exact reference).

## Visualization: Experimental Workflow

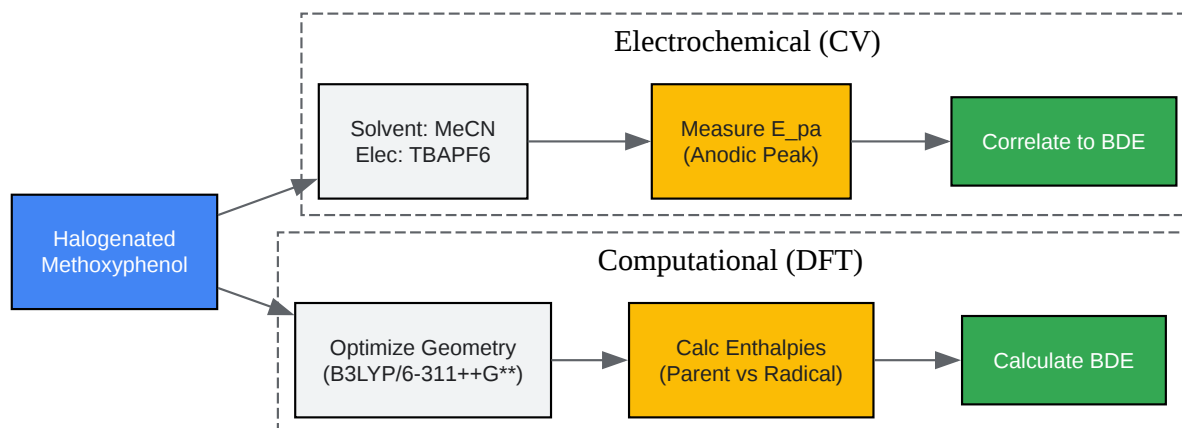

[Click to download full resolution via product page](#)

Figure 2: Dual-pathway workflow for validating thermodynamic stability.

## Implications in Drug Design

Understanding the thermodynamics of these compounds allows for "Metabolic Blocking":

- **Blocking O-Methylation:** The catechol-O-methyltransferase (COMT) enzyme targets the hydroxyl group. Halogenation at the ortho position (6-position) increases steric hindrance and acidity (lower pKa), potentially reducing the affinity for COMT and extending the half-life of catechol-based drugs.
- **Modulating Metabolic Clearance:** Halogens on the ring block CYP450 oxidation at that specific carbon. By placing a halogen at the para position (the most reactive site for nucleophilic attack or hydroxylation), researchers can force metabolism to slower pathways, improving bioavailability.
- **Toxicity Alert:** While stable, halogenated quinones (oxidation products of these phenols) can be electrophilic. High BDEs (via strong EWGs) might reduce radical scavenging but increase the persistence of the parent drug, requiring a balance between efficacy and toxicity.

## References

- Bond Dissociation Enthalpies of Phenolic Antioxidants. Polish Journal of Food and Nutrition Sciences. [\[Link\]](#)
- Critical Re-evaluation of the O-H Bond Dissociation Enthalpy in Phenol. National Research Council Canada / Acc. Chem. Res. [\[Link\]](#)
- Effectiveness of Cyclic Voltammetry in Evaluation of Antioxidant Activity. MDPI / PubMed. [\[Link\]](#)
- Guaiacol Oxidation: Theoretical Insight into Thermochemistry. PubMed. [\[Link\]](#)
- The O-H Bond Dissociation Energies of Substituted Phenols: A DFT Study. MDPI. [\[Link\]](#)
- [To cite this document: BenchChem. \[Thermodynamic Stability of Halogenated Methoxyphenols: A Technical Guide\]. BenchChem, \[2026\]. \[Online PDF\]. Available at: \[https://www.benchchem.com/product/b2874399/docs#thermodynamic-stability-of-halogenated-methoxyphenols-a-technical-guide\]](#)

---

#### Disclaimer & Data Validity:

The information provided in this document is for Research Use Only (RUO) and is strictly not intended for diagnostic or therapeutic procedures. While BenchChem strives to provide accurate protocols, we make no warranties, express or implied, regarding the fitness of this product for every specific experimental setup.

**Technical Support:** The protocols provided are for reference purposes. Unsure if this reagent suits your experiment?

**Need Industrial/Bulk Grade?** [Request Custom Synthesis Quote](#)

# BenchChem

Our mission is to be the trusted global source of essential and advanced chemicals, empowering scientists and researchers to drive progress in science and industry.

## Contact

Address: 3281 E Guasti Rd

Ontario, CA 91761, United States

Phone: (601) 213-4426

Email: [info@benchchem.com](mailto:info@benchchem.com)

[Contact our Ph.D. Support Team for a compatibility check](#)