

Application Note: Precision N-Methylation of Pyrazole-4-Carboxamide

Author: BenchChem Technical Support Team. **Date:** April 2026

Compound of Interest

Compound Name: *N,N*-dimethyl-1H-pyrazole-4-carboxamide

CAS No.: 91918-13-7

Cat. No.: B2873476

[Get Quote](#)

Part 1: Strategic Analysis & Mechanistic Insight[1] The Challenge: Selectivity in a Poly-Nucleophilic System

The methylation of 1H-pyrazole-4-carboxamide presents a classic problem in heterocyclic chemistry: competing nucleophilic sites. The molecule contains four potential sites for alkylation:

- Pyrazolic N1 (Target): The most acidic site (pKa ~14).[1]
- Pyrazolic N2: Tautomerically equivalent to N1 in the unsubstituted parent, but distinct in 3- or 5-substituted derivatives.
- Amide Nitrogen: Significantly less acidic (pKa ~23), but nucleophilic under strong base conditions.[1]
- Amide Oxygen: Capable of O-alkylation (imidate formation) under kinetic control or with hard electrophiles.

Mechanistic Driver: pKa-Guided Base Selection

Success relies on exploiting the

between the pyrazole ring NH and the amide NH.

- Pyrazole NH (): Readily deprotonated by carbonate bases (,).^[1]
- Amide NH (): Requires strong bases (NaH, LiHMDS) for deprotonation.^[1]

Operational Strategy: By using a mild base (Carbonate) in a polar aprotic solvent, we selectively generate the pyrazolate anion without activating the amide nitrogen, ensuring high chemoselectivity for the ring nitrogen.^[1]

Regioselectivity (N1 vs. N2)

- Symmetric Substrates: For the parent 1H-pyrazole-4-carboxamide (unsubstituted at C3/C5), N1 and N2 methylation yield the identical product due to symmetry.^[1]
- Asymmetric Substrates: If the pyrazole bears a substituent at C3 (e.g., the SDHI fungicide class), N1 vs. N2 selectivity becomes critical.^[1] Steric bulk at C3 generally favors alkylation at the distal nitrogen (N1), but electronic effects (tautomeric equilibrium) often complicate this.^[1]

Part 2: Experimental Protocols

Protocol A: Mild Base-Mediated Methylation (Recommended)

Best for: High chemoselectivity (Ring > Amide), scale-up safety, and operational simplicity.^[1]

Reagents & Materials

- Substrate: 1H-Pyrazole-4-carboxamide (1.0 equiv)
- Alkylating Agent: Iodomethane (MeI) (1.2 equiv) [Note: Dimethyl sulfate (DMS) can be substituted but requires stricter safety protocols][1]
- Base: Cesium Carbonate () (1.5 equiv) or Potassium Carbonate () (2.0 equiv)[1]
- Solvent: Anhydrous DMF or Acetonitrile (MeCN) [0.2 M concentration]

Step-by-Step Workflow

- Preparation: Charge an oven-dried round-bottom flask with 1H-pyrazole-4-carboxamide (1.0 equiv) and (1.5 equiv).
- Solvation: Add anhydrous DMF (5 mL per mmol substrate) under an inert atmosphere (or Ar). Stir at Room Temperature (RT) for 15 minutes to allow partial deprotonation.
 - Checkpoint: The suspension may change color or consistency as the pyrazolate anion forms.
- Addition: Cool the mixture to 0 °C (ice bath). Add MeI (1.2 equiv) dropwise via syringe.[1]
 - Why 0 °C? Controls the exotherm and minimizes volatility of MeI.
- Reaction: Remove the ice bath and allow the reaction to warm to RT. Stir for 4–16 hours.
 - Monitoring: Check by TLC (10% MeOH in DCM) or LC-MS.[1] The starting material (polar) should disappear, replaced by a less polar product.[1]
- Workup:
 - Dilute the reaction mixture with EtOAc (10 volumes).

- Wash with Water (3x) to remove DMF and inorganic salts.[1]
- Wash with Brine (1x).[1]
- Dry over

, filter, and concentrate in vacuo.
- Purification: If necessary, purify via flash column chromatography (Gradient: 0-10% MeOH in DCM). Alternatively, recrystallize from EtOH/Heptane.[1]

Protocol B: Strong Base Alkylation (Kinetic Control)

Best for: Unreactive substrates or when rapid conversion is required.[1] Risk: Higher potential for amide side-reactions.[1]

Reagents

- Base: Sodium Hydride (NaH, 60% dispersion in oil) (1.1 equiv)[1]
- Solvent: Anhydrous THF or DMF (0 °C)

Step-by-Step Workflow

- Activation: Suspend NaH (1.1 equiv) in anhydrous THF at 0 °C.
- Deprotonation: Add 1H-pyrazole-4-carboxamide (1.0 equiv) portion-wise. Evolution of gas will be observed. Stir for 30 min at 0 °C.
 - Critical: Do not use excess NaH (>1.2 equiv) to avoid deprotonating the amide.[1]
- Alkylation: Add MeI (1.1 equiv) dropwise.
- Completion: Stir at 0 °C for 1 hour, then warm to RT for 2 hours.
- Quench: Carefully add saturated

solution to quench unreacted hydride. Extract with EtOAc.[2]

Part 3: Analytical Validation & Troubleshooting

Distinguishing Isomers (NMR)

For asymmetric substrates, distinguishing N1-Me from N2-Me is critical.[1]

Feature	N1-Methyl (Distal to bulky R3)	N2-Methyl (Proximal to bulky R3)
NOE Signal	Strong NOE between N-Me and C5-H (or substituent).[1]	Strong NOE between N-Me and C3-Substituent.
HMBC	Coupling of N-Me protons to C5 and C3.	Coupling patterns differ based on ring electronics.
¹³ C NMR	N-Me carbon typically 35-40 ppm.	Similar range; NOE is definitive.

Troubleshooting Table

Issue	Probable Cause	Corrective Action
Low Yield	Product water solubility	During workup, salt the aqueous layer with NaCl or use continuous extraction (DCM).[1]
O-Alkylation	Hard electrophile / Kinetic control	Switch from MeI to DMS (softer). Use thermodynamic conditions (Protocol A, higher temp).
Amide Methylation	Base too strong / Excess base	Switch from NaH to . Ensure stoichiometry is 1:1.1.
Incomplete Reaction	Ion pairing in non-polar solvent	Add 18-Crown-6 (if using) or switch to DMF/DMSO.

Part 4: Visualized Workflows

Reaction Pathway & Selectivity

The following diagram illustrates the competing pathways and the thermodynamic preference for Ring N-methylation.

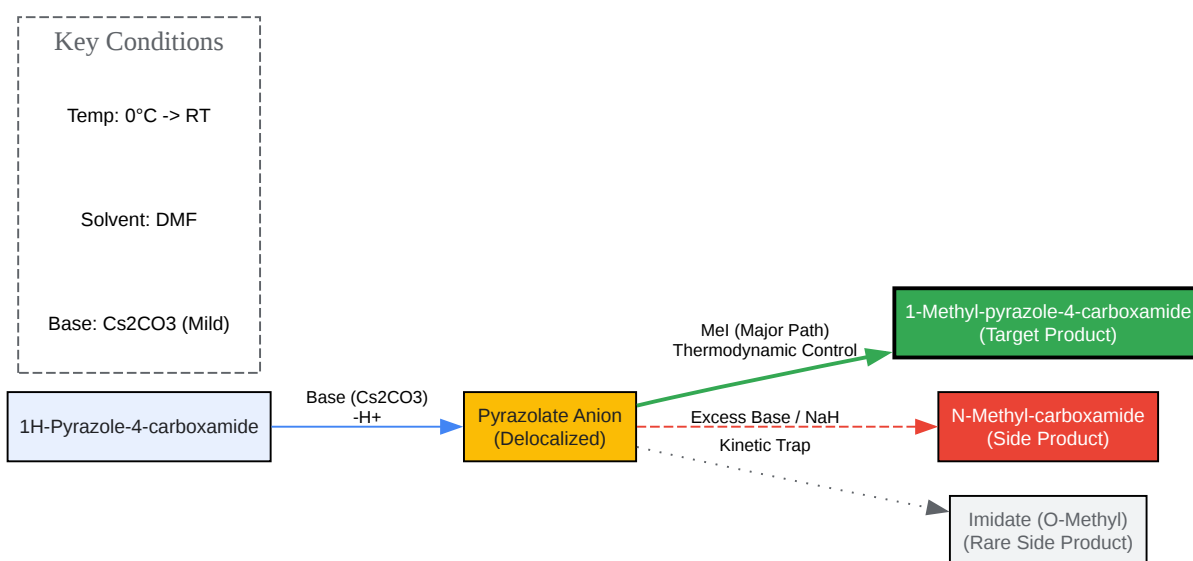

[Click to download full resolution via product page](#)

Caption: Mechanistic pathway showing the selective formation of the N-methyl pyrazole product using mild base conditions.

Experimental Workflow Logic

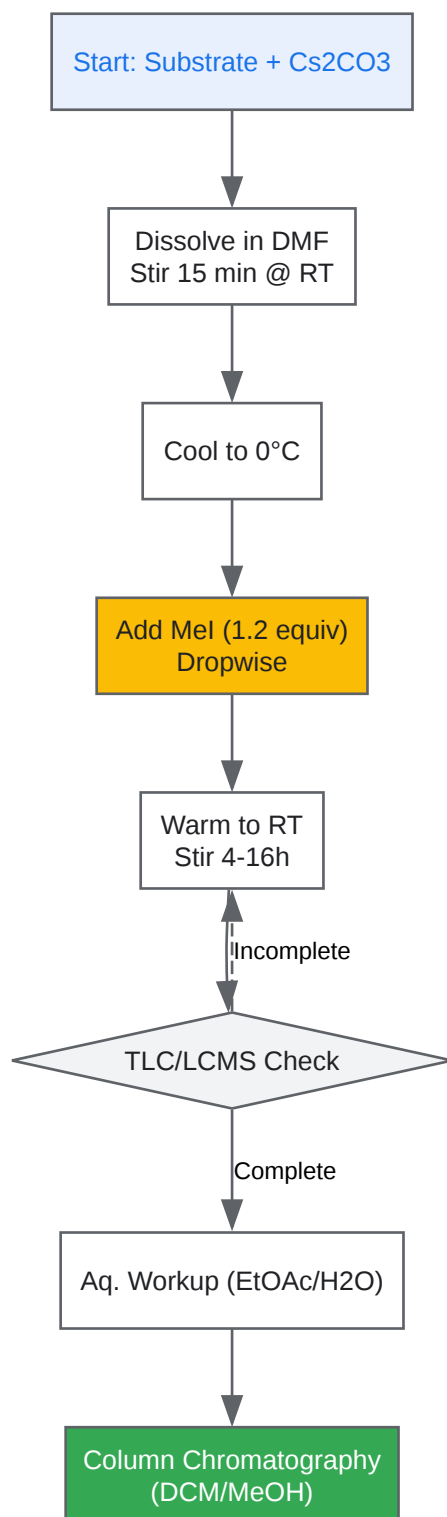

[Click to download full resolution via product page](#)

Caption: Step-by-step experimental workflow for Protocol A (Cesium Carbonate method).

References

- BenchChem Technical Support. (2025).[3] Selective N-Methylation of Pyrazoles: Protocols and Troubleshooting. BenchChem Application Notes. [Link](#)
- Li, J. J. (2014).[1] Name Reactions in Heterocyclic Chemistry II. Wiley. (Context on Pyrazole tautomerism and alkylation dynamics).
- Syngenta Participations AG. (2006). Process for the preparation of pyrazole-4-carboxamides. Patent WO2006015866. (Industrial routes for SDHI fungicides). [Link\[1\]](#)
- Deng, X., & Mani, N. S. (2008).[1][4] Regioselective Synthesis of 1,3,5-Tri- and 1,3,4,5-Tetrasubstituted Pyrazoles. *Journal of Organic Chemistry*, 73(6), 2412–2415.[1] [Link\[1\]](#)
- Fustero, S., et al. (2011).[1] Improved Regioselectivity in the Synthesis of Pyrazoles. *Chemistry – A European Journal*. (Discussion on steric/electronic control in pyrazole alkylation).

Need Custom Synthesis?

BenchChem offers custom synthesis for rare earth carbides and specific isotopic labeling.

Email: info@benchchem.com or [Request Quote Online](#).

Sources

- 1. Structure–antitumor activity relationship of hybrid acetogenins focusing on connecting groups between heterocycles and the linker moiety - PMC [[pmc.ncbi.nlm.nih.gov](https://pubmed.ncbi.nlm.nih.gov/)]
- 2. magritek.com [magritek.com]
- 3. pdf.benchchem.com [pdf.benchchem.com]
- 4. Regioselective Synthesis of 1,3,5-Tri- and 1,3,4,5-Tetrasubstituted Pyrazoles from N-Arylhydrazones and Nitroolefins [organic-chemistry.org]
- To cite this document: BenchChem. [Application Note: Precision N-Methylation of Pyrazole-4-Carboxamide]. BenchChem, [2026]. [Online PDF]. Available at: [<https://www.benchchem.com/product/b2873476/docs#application-note-precision-n-methylation-of-pyrazole-4-carboxamide>]

Disclaimer & Data Validity:

The information provided in this document is for Research Use Only (RUO) and is strictly not intended for diagnostic or therapeutic procedures. While BenchChem strives to provide accurate protocols, we make no warranties, express or implied, regarding the fitness of this product for every specific experimental setup.

Technical Support: The protocols provided are for reference purposes. Unsure if this reagent suits your experiment?

Need Industrial/Bulk Grade? [Request Custom Synthesis Quote](#)

BenchChem

Our mission is to be the trusted global source of essential and advanced chemicals, empowering scientists and researchers to drive progress in science and industry.

Contact

Address: 3281 E Guasti Rd
Ontario, CA 91761, United States
Phone: (601) 213-4426
Email: info@benchchem.com

[Contact our Ph.D. Support Team for a compatibility check](#)