

# Advanced Catalysis Support Center: Troubleshooting 5-Iodo-Pyrazole Cross- Couplings

**Author:** BenchChem Technical Support Team. **Date:** April 2026

## Compound of Interest

Compound Name:	5-iodo-1-propyl-1H-pyrazole-3-carboxylic acid
CAS No.:	2226182-67-6
Cat. No.:	B2871379

[Get Quote](#)

Welcome to the Technical Support Center. As a Senior Application Scientist, I have compiled this definitive guide to address one of the most notorious challenges in heterocyclic medicinal chemistry: transition-metal catalyst poisoning during the cross-coupling of 5-iodo-pyrazoles.

This guide moves beyond generic protocols to explain the thermodynamic and kinetic causality behind experimental failures, providing you with self-validating workflows to rescue your stalled reactions.

## The Mechanistic Root of the Problem

Before troubleshooting, we must understand the causality of the failure. Pyrazoles are privileged scaffolds, but their adjacent nitrogen atoms (N1 and N2) wreak havoc on palladium catalytic cycles. While oxidative addition into the highly reactive C5–I bond is generally rapid, the resulting Pd(II) intermediate is highly susceptible to coordination by the N2 lone pair of a second pyrazole molecule<sup>[1]</sup>.

This heteroatom coordination forms a thermodynamically stable, coordinatively saturated bis-pyrazole Pd(II) complex. Because the metal center is sterically and electronically blocked, the rate-limiting transmetalation step cannot occur. The stalled Pd(II) species eventually degrades, aggregating into inactive palladium nanoparticles (visually observed as "Pd black")<sup>[2]</sup>.

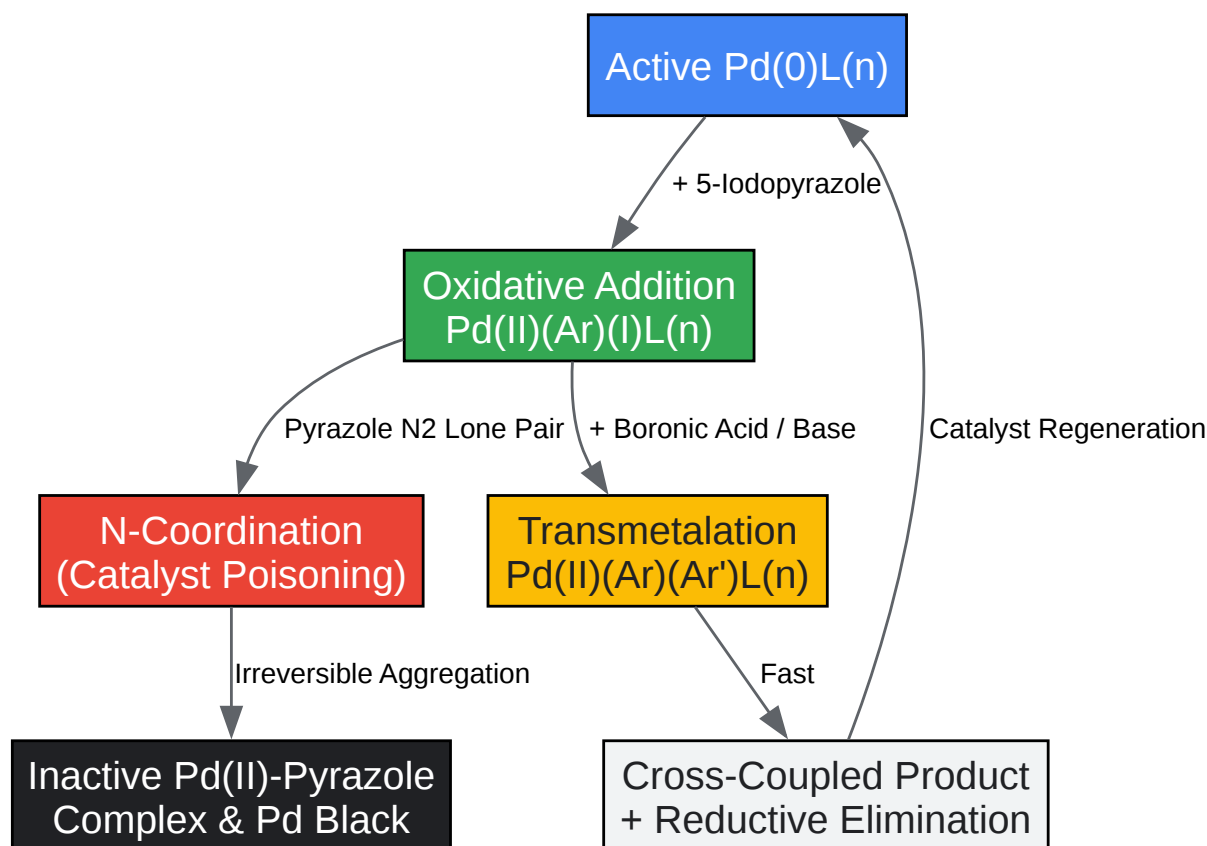

[Click to download full resolution via product page](#)

Figure 1: Divergence of the productive Suzuki catalytic cycle into an inactive catalyst sink via pyrazole N-coordination.

## Troubleshooting Q&A

Q1: My Suzuki-Miyaura coupling with 5-iodo-pyrazole stalls at 10-15% conversion, and the reaction mixture turns black almost immediately. What is happening? A: You are witnessing

rapid catalyst death. The black precipitate is elemental palladium (Pd black)[2]. Because the N2 lone pair of the pyrazole outcompetes your boronic acid for coordination to the Pd(II) center, transmetalation is blocked. The trapped Pd(II) complex is unstable over time at elevated temperatures and undergoes reductive degradation. To fix this, you must either mask the nitrogen electronically (via protecting groups) or physically block it from the metal center (via bulky ligands).

Q2: How do I choose the right protecting group to prevent N-coordination without sterically hindering the adjacent C5-position? A: The choice of N1-protecting group is a delicate balance between electronic masking and steric bulk:

- SEM (2-(Trimethylsilyl)ethoxymethyl): This is the gold standard for 5-iodopyrazoles. It effectively masks the N1 position and provides enough steric bulk to disrupt intermolecular N2 coordination without completely blocking the adjacent C5-I bond from oxidative addition[3].
- N-Methoxy Amides: Recent advancements show that N-methoxy amides can serve as both a protecting group and an anionic directing ligand. They promote the in situ generation of reactive Pd species while preventing the severe heteroatom poisoning typically seen with strongly coordinating nitrogens[1].

Q3: My synthetic route requires an unprotected 1H-pyrazole. What ligand systems can outcompete pyrazole coordination? A: Unprotected 1H-pyrazoles are exceptionally challenging because the acidic N-H proton can be lost under basic coupling conditions, forming a highly nucleophilic pyrazolide anion that aggressively binds palladium. You must use highly sterically demanding, electron-rich ligands:

- Buchwald Biaryl Phosphines (e.g., XPhos, SPhos): The dicyclohexylphosphine moiety provides strong  $\sigma$ -donation to stabilize Pd(0), while the bulky biaryl backbone prevents the coordination of more than one pyrazole ring, keeping a coordination site open for transmetalation.
- PYA (Pyridinium Amidate) Ligands: For highly specific cross-coupling workflows, tailor-made N,N-bidentate ligands like PYA feature a 5-membered N-heterocycle that provides less steric congestion for transmetalation while maintaining a tightly bound, molecularly defined active species that resists poisoning[4].

- Phosphine-Free Systems: In some specialized direct arylations, using simple

with KOAc in DMA at elevated temperatures avoids phosphine poisoning entirely, relying on the solvent and acetate to stabilize the active catalytic species[5].

## Quantitative Data Summary: Mitigation Strategies

Strategy	Specific Reagent / Ligand	Mechanism of Rescue	Recommended Use Case
Steric Shielding	SEM-Cl, NaH	Blocks N1, sterically hinders N2 coordination without blocking C5-I.	Standard Suzuki/Buchwald couplings where deprotection is viable later.
Ligand Bulk	XPhos Pd G2	Biaryl backbone prevents formation of bis-pyrazole Pd(II) complexes.	When protecting groups cannot be used; high steric hindrance required.
Bidentate Anchoring	PYA Ligands	Maintains a molecularly defined active species; resists displacement.	Advanced $\alpha$ -arylation or highly sensitive substrates.
Directing Groups	N-Methoxy Amides	Acts as an anionic ligand to promote in situ Pd generation[1].	C-H functionalization or complex late-stage functionalization.

## Self-Validating Experimental Protocol

Workflow: Suzuki-Miyaura Coupling of 5-Iodo-1-(SEM)-1H-pyrazole

This protocol utilizes a pre-catalyst system (XPhos Pd G2) to ensure rapid, quantitative generation of the active L1Pd(0) species, bypassing the initiation lag that often allows pyrazole poisoning to take hold.

Materials:

- 5-Iodo-1-(SEM)-1H-pyrazole (1.0 equiv)
- Arylboronic acid (1.5 equiv)
- XPhos Pd G2 (2-5 mol%)
- (2.0 equiv, 0.5 M aqueous solution)
- 1,4-Dioxane (Degassed)

#### Step-by-Step Methodology:

- **Reaction Setup:** In a Schlenk tube or vial, combine the 5-iodo-pyrazole, arylboronic acid, and XPhos Pd G2.
- **Inert Atmosphere:** Evacuate and backfill the vessel with Argon (3 cycles). Causality: Oxygen rapidly oxidizes the electron-rich XPhos ligand, destroying the catalyst before it can enter the cycle.
- **Solvent Addition:** Add degassed 1,4-Dioxane, followed by the aqueous solution.
- **Self-Validation Checkpoint 1 (Initiation):** Heat the mixture to 80 °C. Within 5 minutes, the solution should transition from a pale yellow to a deep red/orange. This visual cue confirms the successful generation of the active XPhos-Pd(0) species.
- **Self-Validation Checkpoint 2 (Poisoning Monitor):** Monitor the reaction at the 15-minute mark. If the solution remains red/orange or turns brown, the catalytic cycle is productive. If the solution turns opaque black with visible particulate matter on the glass walls, catalyst poisoning has occurred. Abort, check your SEM protection integrity, and verify solvent degassing.
- **Completion & Workup:** Stir for 2-4 hours until complete consumption of the starting material is observed via TLC/LCMS. Cool to room temperature, dilute with EtOAc, wash with brine, and purify via silica gel chromatography.

## Troubleshooting Decision Matrix

Use the following logical workflow to diagnose and rescue failing reactions.

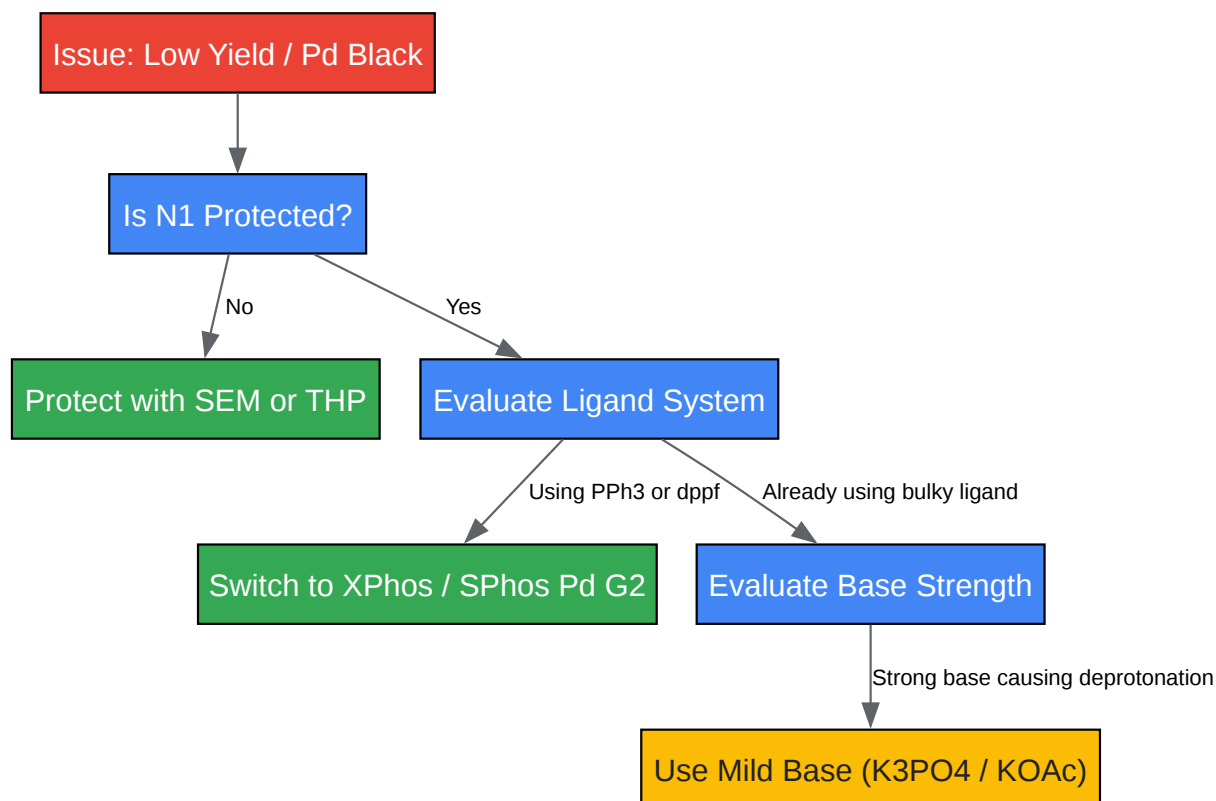

[Click to download full resolution via product page](#)

Figure 2: Decision matrix for troubleshooting stalled palladium-catalyzed couplings involving 5-iodopyrazoles.

## References

- [Benchchem Technical Support.3-Bromo-5-iodopyrazole | 1015779-70-0. Benchchem. 3](#)
- [National Institutes of Health \(PMC\).Bypassing the Limitations of Directed C–H Functionalizations of Heterocycles. NIH. 1](#)
- [University of Bern \(BORIS Portal\).Enhancing activity and selectivity of palladium catalysts in ketone  \$\alpha\$ -arylation by tailoring the imine chelate of pyridinium amidate \(PYA\) ligands. BORIS. 4](#)
- [Royal Society of Chemistry.Conditions for Palladium-Catalyzed Direct Arylations of 4- Bromo and 4-Iodo N-Substituted Pyrazoles. RSC. 5](#)
- [American Chemical Society \(Organometallics\).Formation and Role of Palladium Chalcogenide and Other Species in Suzuki–Miyaura and Heck C–C Coupling Reactions Catalyzed with Palladium\(II\) Complexes of Organochalcogen Ligands: Realities and Speculations. ACS. 2](#)

#### Need Custom Synthesis?

*BenchChem offers custom synthesis for rare earth carbides and specific isotopic labeling.*

*Email: [info@benchchem.com](mailto:info@benchchem.com) or [Request Quote Online](#).*

## Sources

- [1. Bypassing the Limitations of Directed C–H Functionalizations of Heterocycles - PMC \[pmc.ncbi.nlm.nih.gov\]](#)
- [2. pubs.acs.org \[pubs.acs.org\]](#)
- [3. 3-Bromo-5-iodopyrazole | 1015779-70-0 | Benchchem \[benchchem.com\]](#)
- [4. boris-portal.unibe.ch \[boris-portal.unibe.ch\]](#)
- [5. pubs.rsc.org \[pubs.rsc.org\]](#)
- To cite this document: BenchChem. [Advanced Catalysis Support Center: Troubleshooting 5-Iodo-Pyrazole Cross-Couplings]. BenchChem, [2026]. [Online PDF]. Available at: [<https://www.benchchem.com/product/b2871379/docs#advanced-catalysis-support-center-troubleshooting-5-iodo-pyrazole-cross-couplings>]

**Disclaimer & Data Validity:**

The information provided in this document is for Research Use Only (RUO) and is strictly not intended for diagnostic or therapeutic procedures. While BenchChem strives to provide accurate protocols, we make no warranties, express or implied, regarding the fitness of this product for every specific experimental setup.

**Technical Support:** The protocols provided are for reference purposes. Unsure if this reagent suits your experiment?

**Need Industrial/Bulk Grade?** [Request Custom Synthesis Quote](#)

## BenchChem

Our mission is to be the trusted global source of essential and advanced chemicals, empowering scientists and researchers to drive progress in science and industry.

### Contact

Address: 3281 E Guasti Rd  
Ontario, CA 91761, United States  
Phone: (601) 213-4426  
Email: [info@benchchem.com](mailto:info@benchchem.com)

[Contact our Ph.D. Support Team for a compatibility check](#)