

Application Note: High-Throughput Library Synthesis Using 3,4-Disubstituted Piperidine Scaffolds

Author: BenchChem Technical Support Team. **Date:** May 2026

Compound of Interest

Compound Name:	4-Methoxypiperidin-3-amine dihydrochloride
CAS No.:	2193065-67-5
Cat. No.:	B2865605

[Get Quote](#)

-Rich Libraries

Introduction: Escaping "Flatland" in Drug Discovery

In modern medicinal chemistry, the over-reliance on flat, planar aromatic systems has contributed to high attrition rates due to poor physicochemical properties (solubility, lipophilicity) and promiscuous binding. The "Escape from Flatland" concept, popularized by Lovering et al., posits that increasing the fraction of saturated carbons (

) and introducing chirality correlates strongly with clinical success.^{[1][2]}

The 3,4-disubstituted piperidine scaffold represents a "privileged structure" that offers a distinct advantage over the ubiquitous 4-substituted piperidines. By introducing a substituent at the 3-

position, the ring adopts a defined chair conformation that projects vectors into specific regions of the biological target's binding pocket, often inaccessible to planar analogues.

Scientific Rationale

- **Vectorial Diversity:** Unlike 4-substituted piperidines (linear vectors), 3,4-systems offer orthogonal vectors (vs.), allowing for precise probing of receptor sub-pockets.
- **Chirality:** The 3,4-substitution pattern creates two stereocenters, offering four discrete stereoisomers to fine-tune potency and metabolic stability.
- **IP Space:** These scaffolds are less represented in commercial libraries compared to their 4-substituted counterparts, offering novel intellectual property opportunities.

Strategic Overview: Scaffold Selection & Library Design

For this protocol, we utilize a modular, divergent synthesis strategy. We select a scaffold that possesses orthogonal protecting groups to facilitate parallel synthesis without intermediate purification bottlenecks.

Selected Scaffold: (3R,4S)-1-N-Boc-3-amino-4-piperidinecarboxylic acid methyl ester

- **Handle A (C3-Amine):** Ready for acylation, sulfonylation, or reductive amination.
- **Handle B (C4-Ester):** Precursor for amides (via hydrolysis) or alcohols (via reduction).
- **Handle C (N1-Piperidine):** Protected by Boc; serves as a late-stage diversity point for solubility tuning or lipophilic capping.

DOT Diagram: Strategic Library Logic



[Click to download full resolution via product page](#)

Figure 1: Divergent synthesis strategy transforming a single core scaffold into a multidimensional library via orthogonal functionalization.

Detailed Protocol: Parallel Solution-Phase Synthesis

Objective: To synthesize a 96-member library of diamides based on the (3R,4S)-piperidine core. Scale: 100 μ mol per well.

Materials & Reagents

Reagent	Function	Grade/Notes
(3R,4S)-1-Boc-3-amino-4-methoxycarbonylpiperidine	Core Scaffold	>98% ee
N,N-Diisopropylethylamine (DIEA)	Base	Anhydrous
HATU	Coupling Agent	High efficiency for hindered amines
Trifluoroacetic acid (TFA)	Deprotection	Reagent grade
Acid Chlorides / Sulfonyl Chlorides ()	Diversity Set 1	12 selected electrophiles
Amines ()	Diversity Set 2	8 selected nucleophiles
DCE (1,2-Dichloroethane)	Solvent	Anhydrous

Workflow Diagram

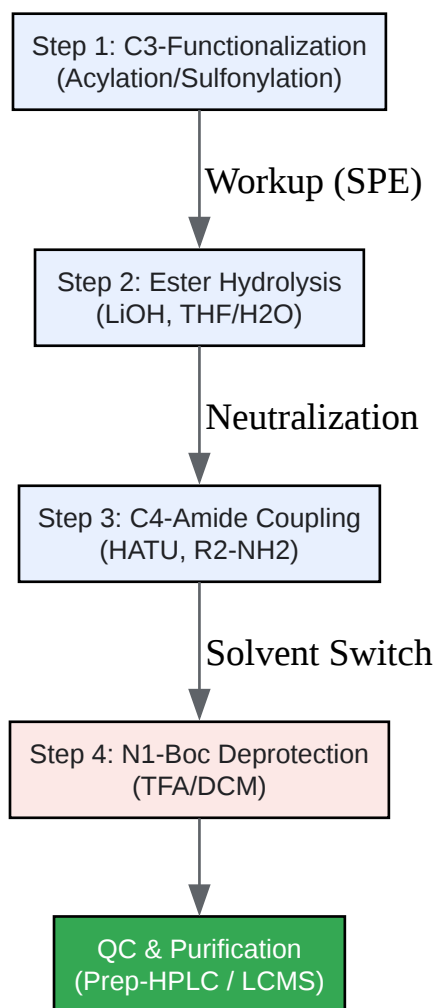

[Click to download full resolution via product page](#)

Figure 2: Step-by-step parallel synthesis workflow for 3,4-disubstituted piperidine library generation.

Experimental Procedure

Step 1:

Functionalization (C3-Amine)

Rationale: The C3-amine is the most nucleophilic site. We functionalize it first to avoid interference during ester hydrolysis.

- Stock Prep: Dissolve the scaffold (1.0 equiv) in DCM. Prepare 0.5 M stocks of Acid Chlorides (

-Cl) in DCM.

- Reaction: In a 96-well reaction block, add scaffold solution (100 μ mol). Add DIEA (3.0 equiv).
- Addition: Add

-Cl (1.2 equiv) slowly at 0°C (using a cooling block), then allow to warm to RT. Shake for 4 hours.
- Scavenging: Add polymer-supported trisamine scavenger resin (3.0 equiv) to remove excess acid chloride. Shake for 2 hours.
- Filtration: Filter into a receiving plate. Evaporate solvent.

Step 2: Ester Hydrolysis

Rationale: Gentle hydrolysis is required to prevent epimerization at the C4 chiral center.

- Dissolution: Redissolve the Step 1 products in THF:MeOH (1:1, 1 mL).
- Hydrolysis: Add LiOH (2.0 M aqueous, 4.0 equiv).
- Incubation: Seal plate and shake at 40°C for 12 hours.
- Workup: Neutralize with 1M HCl to pH 5-6. Extract with EtOAc (x3). Dry over

and concentrate.
 - Critical Checkpoint: Analyze 5 random wells by LCMS to ensure complete hydrolysis and retention of stereochemistry (no diastereomeric peak splitting).

Step 3:

Functionalization (C4-Carboxylate)

Rationale: HATU is chosen over EDC/HOBt to minimize racemization during the activation of the chiral C4-acid.

- Activation: Dissolve the carboxylic acid intermediate in DMF (0.5 mL). Add DIEA (4.0 equiv) and HATU (1.2 equiv). Shake for 10 mins.

- Coupling: Add Amine (, 1.5 equiv).
- Reaction: Shake at RT for 16 hours.
- Purification: Perform Solid Phase Extraction (SPE) using SCX-2 cartridges (catch-and-release) if contains a basic nitrogen, or standard liquid-liquid extraction for neutral amides.

Step 4: N1-Deprotection (Optional/Final)

- Deprotection: Treat residues with 20% TFA in DCM (1 mL) for 1 hour.
- Finish: Evaporate volatiles under stream. Lyophilize from water/acetonitrile to obtain the TFA salt.

Quality Control & Validation

Trustworthiness in library synthesis is binary: the compound is either correct, or it is biological noise.

QC Criteria

- Purity: >85% by UV (254 nm).
- Identity: Molecular ion confirmed by ESI-MS.
- Stereochemical Integrity:
 - NMR of representative samples must show characteristic coupling constants () consistent with the starting cis or trans configuration.
 - Note: Trans-3,4-disubstituted piperidines typically display

Hz (diaxial), while cis isomers show smaller couplings (

Hz) depending on the conformer population.

Troubleshooting Guide

Issue	Probable Cause	Corrective Action
Low Yield in Step 1	Steric hindrance of C3-amine	Switch solvent to DCE and heat to 50°C; use PyBOP instead of acid chlorides.
Epimerization at Step 2	Harsh hydrolysis conditions	Switch LiOH to TMSOK (Potassium trimethylsilanolate) in anhydrous THF.
Incomplete Coupling (Step 3)	Amine nucleophile is weak (e.g., aniline)	Use POCl ₃ activation or convert acid to acid chloride in situ using Ghosez's reagent.

References

- Lovering, F., Bikker, J., & Humblet, C. (2009).[1][2][3] Escape from Flatland: Increasing Saturation as an Approach to Improving Clinical Success. *Journal of Medicinal Chemistry*. [Link](#)
- James, T., et al. (2022). Exploration of piperidine 3D fragment chemical space: synthesis and 3D shape analysis of fragments derived from 20 regio- and diastereoisomers of methyl substituted pipercolinates. *RSC Medicinal Chemistry*. [Link](#)
- Klegraf, E., & Kunz, H. (2012).[4][5] Stereoselective Synthesis of 3-Substituted and 3,4-Disubstituted Piperidine Derivatives. *Zeitschrift für Naturforschung B*. [Link](#)
- Murthy, K. S. K., et al. (2003).[6] Enantioselective synthesis of 3-substituted-4-aryl piperidines useful for the preparation of paroxetine.[6] *Tetrahedron Letters*. [Link](#)[6]
- Filippov, D. V., et al. (2017).[7] Piperidine and octahydropyrano[3,4-c]pyridine scaffolds for drug-like molecular libraries.[7] *Bioorganic & Medicinal Chemistry*. [Link](#)[7]

Need Custom Synthesis?

BenchChem offers custom synthesis for rare earth carbides and specific isotopic labeling.

Email: info@benchchem.com or [Request Quote Online](#).

Sources

- [1. semanticscholar.org](https://www.semanticscholar.org) [[semanticscholar.org](https://www.semanticscholar.org)]
- [2. Escape from flatland: increasing saturation as an approach to improving clinical success - PubMed](#) [pubmed.ncbi.nlm.nih.gov]
- [3. pubs.acs.org](https://pubs.acs.org) [pubs.acs.org]
- [4. researchgate.net](https://www.researchgate.net) [[researchgate.net](https://www.researchgate.net)]
- [5. znaturforsch.com](https://www.znaturforsch.com) [[znaturforsch.com](https://www.znaturforsch.com)]
- [6. Sci-Hub. Enantioselective synthesis of 3-substituted-4-aryl piperidines useful for the preparation of paroxetine / Tetrahedron Letters, 2003](#) [sci-hub.sg]
- [7. Piperidine and octahydropyrano\[3,4-c\] pyridine scaffolds for drug-like molecular libraries of the European Lead Factory - PubMed](#) [pubmed.ncbi.nlm.nih.gov]
- To cite this document: BenchChem. [Application Note: High-Throughput Library Synthesis Using 3,4-Disubstituted Piperidine Scaffolds]. BenchChem, [2026]. [Online PDF]. Available at: [<https://www.benchchem.com/product/b2865605/docs#application-note-high-throughput-library-synthesis-using-3-4-disubstituted-piperidine-scaffolds>]

Disclaimer & Data Validity:

The information provided in this document is for Research Use Only (RUO) and is strictly not intended for diagnostic or therapeutic procedures. While BenchChem strives to provide accurate protocols, we make no warranties, express or implied, regarding the fitness of this product for every specific experimental setup.

Technical Support: The protocols provided are for reference purposes. Unsure if this reagent suits your experiment?

Need Industrial/Bulk Grade? [Request Custom Synthesis Quote](#)

BenchChem

Our mission is to be the trusted global source of essential and advanced chemicals, empowering scientists and researchers to drive progress in science and industry.

Contact

Address: 3281 E Guasti Rd

Ontario, CA 91761, United States

Phone: (601) 213-4426

Email: info@benchchem.com

[Contact our Ph.D. Support Team for a compatibility check](#)