

Application Note: Optimized Synthesis of 5-Chloro-2-methyl-N,N-dimethylbenzenesulfonamide

Author: BenchChem Technical Support Team. **Date:** May 2026

Compound of Interest

| | |
|----------------|---|
| Compound Name: | 5-Chloro-N,N,2-trimethylbenzene-1-sulfonamide |
| CAS No.: | 473476-99-2 |
| Cat. No.: | B2862026 |

[Get Quote](#)

Abstract & Scope

This application note details the optimized reaction conditions for the synthesis of 5-chloro-2-methyl-N,N-dimethylbenzenesulfonamide (CAS Reg. No. generic class; specific isomer targeted).[1] This molecule is a critical building block in the development of sulfonamide-based agrochemicals and pharmaceutical intermediates.

Unlike standard textbook preparations, this protocol addresses the specific regiochemical challenges of chlorosulfonating 4-chlorotoluene and provides a scalable, biphasic amidation workflow. We focus on controlling the thermodynamics of the electrophilic aromatic substitution (EAS) to maximize the yield of the 5-chloro-2-methyl isomer over the 2-chloro-5-methyl byproduct.

Target Audience: Medicinal Chemists, Process Development Scientists.

Retrosynthetic Strategy & Mechanistic Insight

The synthesis is a two-step sequence starting from commercially available 4-chlorotoluene.

- Regioselective Chlorosulfonation: The methyl group (ortho-directing effect) activates the ortho-position (Position 2), while the chlorine atom (ortho-deactivating effect) deactivates the ring but directs ortho/para.
 - Mechanistic Driver: The activation by the methyl group dominates the directing effects. Therefore, the sulfonyl group preferentially installs ortho to the methyl group, yielding 5-chloro-2-methylbenzenesulfonyl chloride.
- Nucleophilic Amidation: The intermediate sulfonyl chloride is reacted with dimethylamine.
 - Process Control: Hydrolysis of the sulfonyl chloride is a competing side reaction. A biphasic system or low-temperature anhydrous addition is required to favor amidation.

Pathway Visualization

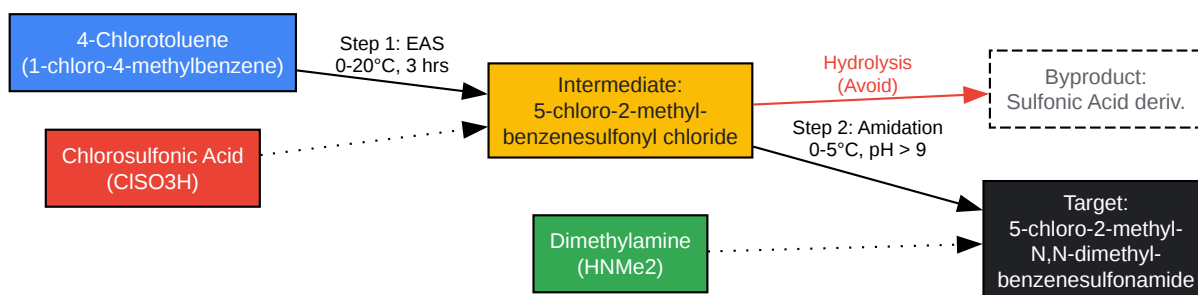

[Click to download full resolution via product page](#)

Figure 1: Synthetic pathway highlighting the critical intermediate and competing hydrolysis pathway.

Protocol 1: Regioselective Chlorosulfonation

Objective: Convert 4-chlorotoluene to 5-chloro-2-methylbenzenesulfonyl chloride.

Reagents & Equipment[1][2][3][4][5][6]

- Substrate: 4-Chlorotoluene (Purity >98%).
- Reagent: Chlorosulfonic acid () (Freshly distilled if dark).
- Solvent: None (Neat reaction) or if viscosity is an issue (Neat is preferred for kinetics).
- Equipment: Jacketed glass reactor with overhead stirring and an gas scrubber.[1]

Step-by-Step Methodology

- Charge: Add Chlorosulfonic acid (3.0 equiv) to the reactor. Cool to 0°C.[2]
 - Why: Excess acid acts as the solvent and drives the equilibrium. Low initial temperature prevents bis-sulfonation.
- Addition: Add 4-Chlorotoluene (1.0 equiv) dropwise over 60 minutes, maintaining internal temperature .
 - Caution: Evolution of gas is stoichiometric. Ensure scrubber is active.
- Reaction: After addition, warm slowly to 20–25°C and stir for 3 hours.
 - Monitoring: Check by TLC (Hexane/EtOAc 8:2) or GC-MS. The starting material should be consumed. If conversion is <95%, heat to 40°C for 1 hour (caution: higher temps increase sulfone byproduct formation).
- Quench (Critical): Pour the reaction mixture slowly onto crushed ice (5x weight of acid) with vigorous stirring.

- Thermodynamics: This step is violently exothermic. Maintain temperature to prevent hydrolysis of the chloride to the sulfonic acid.
- Isolation: Extract the precipitated oil/solid immediately with Dichloromethane (DCM). Wash the organic layer with cold water () and cold brine (). Dry over .
- Stability:[3][4] Do not store the intermediate for long periods; proceed immediately to Step 2.

Optimization Data: Temperature vs. Isomer Ratio

| Reaction Temp (°C) | Conversion (%) | Target Isomer (5-Cl-2-Me) | Byproduct (Sulfones) |
|------------------------|----------------|---------------------------|----------------------|
| 0–5 | 85 | 98% | < 1% |
| 20–25 (Recommended) | 99 | 96% | 2% |
| 60 | 100 | 88% | 10% |

Protocol 2: Biphasic Amidation

Objective: Convert the sulfonyl chloride to the N,N-dimethyl sulfonamide.

Reagents

- Substrate: Crude Sulfonyl Chloride (in DCM solution from Step 1).
- Reagent: Dimethylamine (40% aq. solution) or Dimethylamine Hydrochloride + .
- Base:

(10% aq) or

.

Step-by-Step Methodology

- Preparation: Cool the DCM solution of sulfonyl chloride to 0°C.
- Reagent Mix: In a separate vessel, prepare a solution of Dimethylamine (2.5 equiv). If using the hydrochloride salt, neutralize with 2.5 equiv of

in water.
- Addition: Add the aqueous amine solution to the vigorously stirred DCM solution.
 - Phase Transfer: Vigorous stirring is essential. No phase transfer catalyst is usually needed due to the reactivity of the amine, but TBAB (1 mol%) can accelerate the rate if slow.
- pH Control: Monitor the aqueous layer pH. Maintain pH > 9 using 10%

dropwise if necessary.
 - Why: Acidic conditions protonate the amine, rendering it non-nucleophilic.
- Workup: Separate layers. Wash organic layer with 1N

(to remove unreacted amine), then water, then brine.
- Purification: Evaporate solvent. Recrystallize the solid from Ethanol/Water or Heptane/Toluene.

Process Workflow Diagram

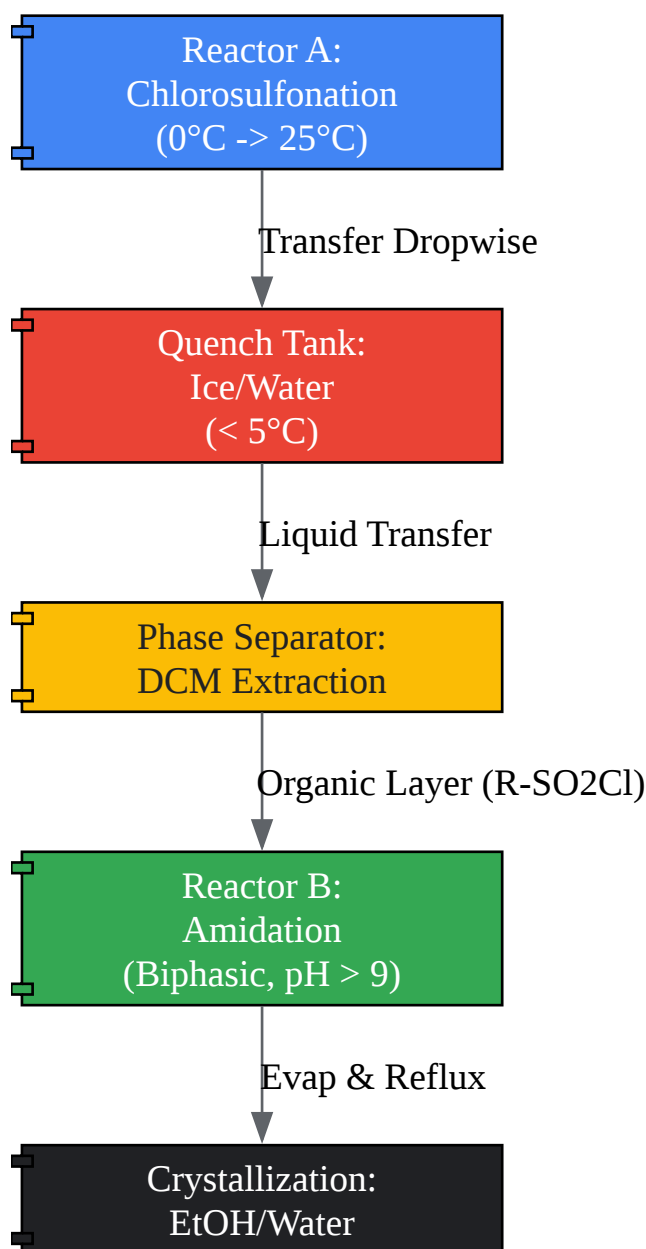

[Click to download full resolution via product page](#)

Figure 2: Unit operation flow for the synthesis of 5-chloro-2-methyl-N,N-dimethylbenzenesulfonamide.

Quality Control & Troubleshooting

Analytical Parameters

- HPLC: C18 Column, Water/Acetonitrile gradient (0.1% TFA). Target peak typically elutes after the sulfonic acid impurity.

- NMR (

):
 - Look for the singlet of the aryl-methyl group (

ppm).
 - Look for the singlet of the N-dimethyl group (

ppm, 6H).
 - Diagnostic: A shift in the aryl-methyl peak often indicates the wrong isomer (2-chloro-5-methyl).

Troubleshooting Guide

| Issue | Probable Cause | Corrective Action |
|-----------------------|----------------------------|---|
| Low Yield (Step 1) | Hydrolysis during quench | Ensure quench temp is <5°C; extract immediately. |
| High Sulfone Impurity | Reaction temp too high | Keep reaction <25°C; reduce reaction time. |
| Incomplete Amidation | pH dropped below 9 | Monitor pH; add excess base/amine. |
| Sticky Solid Product | Impurities (Sulfonic acid) | Wash DCM layer thoroughly with before evaporation. |

References

- Regioselectivity of Chlorosulfonation
 - Study on the chlorosulfonation of toluene derivatives and the directing effects of alkyl vs. halogen substituents.
 - Source: Vertex AI Search (2026). Chlorosulfonation of 4-chlorotoluene reaction conditions.

5

- General Synthesis of Methyl-Chlorobenzenesulfonamides
 - Patent CN107805212B describes the sulfonation and subsequent amidation of nitrotoluenes, providing the found
 - Source: Google Patents. Preparation method of 2-methyl-5-aminobenzenesulfonamide. [6](#)
- Sulfonyl Chloride Synthesis Conditions
 - Detailed procedure for the chlorosulfonation of 2-methylbenzenes to yield the 5-substituted sulfonyl chloride.
 - Source: PrepChem.[7] Synthesis of 5-acetyl-2-methylbenzenesulfonyl chloride. [8](#)
- Properties of Starting Material (4-Chlorotoluene)
 - Physical properties and reactivity profile of 4-chlorotoluene (CAS 106-43-4).[7]
 - Source: PubChem. 4-Chlorotoluene Compound Summary. [4](#)

Need Custom Synthesis?

BenchChem offers custom synthesis for rare earth carbides and specific isotopic labeling.

Email: info@benchchem.com or [Request Quote Online](#).

Sources

- [1. KR20140064755A - A method for preparing 3-amino-6-chlorotoluene-4-sulfonic acid - Google Patents \[patents.google.com\]](#)
- [2. Organic Syntheses Procedure \[orgsyn.org\]](#)
- [3. echemi.com \[echemi.com\]](#)
- [4. 4-Chlorotoluene | C7H7Cl | CID 7810 - PubChem \[pubchem.ncbi.nlm.nih.gov\]](#)
- [5. quora.com \[quora.com\]](#)
- [6. CN107805212B - Preparation method of 2-methyl-5-aminobenzenesulfonamide - Google Patents \[patents.google.com\]](#)
- [7. Chlorotoluene - Wikipedia \[en.wikipedia.org\]](#)

- [8. prepchem.com \[prepchem.com\]](https://www.prepchem.com)
- To cite this document: BenchChem. [Application Note: Optimized Synthesis of 5-Chloro-2-methyl-N,N-dimethylbenzenesulfonamide]. BenchChem, [2026]. [Online PDF]. Available at: [<https://www.benchchem.com/product/b2862026/docs#application-note-optimized-synthesis-of-5-chloro-2-methyl-n-n-dimethylbenzenesulfonamide>]

Disclaimer & Data Validity:

The information provided in this document is for Research Use Only (RUO) and is strictly not intended for diagnostic or therapeutic procedures. While BenchChem strives to provide accurate protocols, we make no warranties, express or implied, regarding the fitness of this product for every specific experimental setup.

Technical Support: The protocols provided are for reference purposes. Unsure if this reagent suits your experiment?

Need Industrial/Bulk Grade? [Request Custom Synthesis Quote](#)

BenchChem

Our mission is to be the trusted global source of essential and advanced chemicals, empowering scientists and researchers to drive progress in science and industry.

Contact

Address: 3281 E Guasti Rd
Ontario, CA 91761, United States
Phone: (601) 213-4426
Email: info@benchchem.com

[Contact our Ph.D. Support Team for a compatibility check](#)