

comparative study of electrophilic vs. nucleophilic fluorination methods

Author: BenchChem Technical Support Team. **Date:** April 2026

Compound of Interest

Compound Name: *lithium(1+) ion 2-fluoro-2-(pyridin-2-yl)acetate*

CAS No.: 1803584-38-4

Cat. No.: B2859509

[Get Quote](#)

Comparative Study of Electrophilic vs. Nucleophilic Fluorination Methods: A Practical Guide for Late-Stage Functionalization

As an application scientist overseeing late-stage functionalization and API synthesis, I frequently encounter a critical decision point in drug development: how to efficiently and selectively install a fluorine atom into a complex organic scaffold. The strategic incorporation of fluorine profoundly alters a molecule's pKa, lipophilicity, and metabolic stability (1)[1]. However, forming a carbon-fluorine (C-F) bond requires overcoming significant kinetic and thermodynamic barriers.

This guide objectively compares the two primary paradigms of fluorination—electrophilic (F+) and nucleophilic (F-)—detailing their mechanistic causality, reagent selection, and validated experimental protocols to help researchers design self-validating, high-yield synthetic systems.

Mechanistic Causality & Strategic Selection

The choice between electrophilic and nucleophilic fluorination is entirely dictated by the electronic nature of the target substrate (2)[2].

Nucleophilic Fluorination (F⁻)

Nucleophilic fluorination relies on the delivery of a fluoride anion to an electron-deficient carbon center, typically via an SN2 substitution or nucleophilic addition (2)[2].

- **The Causality of Reactivity:** The fluoride ion presents a unique dichotomy in organic synthesis. In protic media, it is highly solvated via strong hydrogen bonds, which severely diminishes its nucleophilicity. Conversely, in aprotic media, "naked" fluoride acts as a hard, strong base rather than a nucleophile (3)[3]. This basicity often leads to competitive E2 elimination side reactions, yielding undesired alkenes. To counteract this, modern nucleophilic reagents (e.g., DAST, Deoxo-Fluor, XtalFluor) are engineered to activate the substrate (e.g., converting a hydroxyl group into a superior leaving group) while simultaneously delivering the fluoride intramolecularly or within a tight ion pair, thereby suppressing elimination pathways (4)[4].

Electrophilic Fluorination (F⁺)

Electrophilic fluorination involves the transfer of an electron-deficient fluorine atom to an electron-rich nucleophilic center, such as an enolate, alkene, or arene (5)[5].

- **The Causality of Reactivity:** Because elemental fluorine (F₂) is dangerously reactive and unselective, modern "second-generation" reagents utilize a polarized N-F bond (6)[6]. Reagents like Selectfluor and NFSI feature an adjacent electron-withdrawing nitrogen or sulfonimide core that renders the fluorine atom highly electrophilic. When an electron-rich substrate attacks this N-F bond, the weak bond cleaves, transferring the fluorine atom and leaving behind a stable, neutral, or cationic nitrogen leaving group (1)[1].

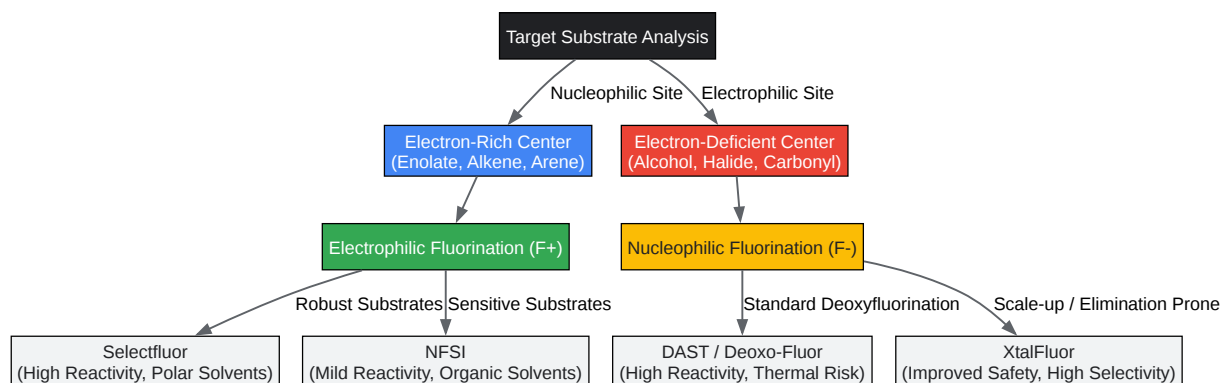

[Click to download full resolution via product page](#)

Caption: Logical workflow for selecting between electrophilic and nucleophilic fluorination strategies.

Reagent Performance & Comparative Data

The selection of a specific reagent within these paradigms hinges on thermal stability, functional group tolerance, and solubility.

Table 1: Quantitative Comparison of Nucleophilic Deoxyfluorinating Agents (Data sourced from comparative differential scanning calorimetry (DSC) studies (4)[4])

Reagent	Structure/Type	Thermal Stability (Decomposition)	Safety Profile	Key Application
DAST	S-F (Liquid)	Onset: 140 °C ($\Delta H = -1700$ J/g)	High risk (explosive)	Standard lab-scale deoxyfluorination
Deoxo-Fluor	S-F (Liquid)	Onset: 140 °C ($\Delta H = -1100$ J/g)	Moderate risk	Safer alternative to DAST
XtalFluor-E	S-F (Solid)	Onset > 140 °C (Stable solid)	Safe, bench-stable	Scale-up, elimination-prone substrates

Table 2: Comparison of Electrophilic N-F Reagents (Data sourced from reactivity profiling (7) [7])

Reagent	Structure/Type	Reactivity Profile	Solubility	Key Application
Selectfluor	N-F (F-TEDA-BF ₄)	High	Polar (MeCN, DMF, Water)	α -fluorination, late-stage functionalization
NFSI	N-F (Sulfonimide)	Mild	Non-polar/Polar (DCM, THF)	Enantioselective catalysis, sensitive substrates

Experimental Workflows & Validated Protocols

The following protocols are designed as self-validating systems, where the choice of solvent and additives directly mitigates the inherent side reactions of the fluorination pathway.

Protocol A: Electrophilic α -Fluorination of a β -Ketoester using Selectfluor

This protocol leverages the inherent enolization of β -ketoesters to drive the reaction without strong external bases (7)[7].

- Preparation: In an oven-dried round-bottom flask equipped with a magnetic stir bar, dissolve the β -ketoester (1.0 equiv, e.g., ethyl 2-oxocyclohexanecarboxylate) in anhydrous acetonitrile (0.2 M concentration) under an inert argon atmosphere.
- Reagent Addition: Add Selectfluor (1.1 equiv) in one portion at room temperature.
 - Causality Check: Selectfluor is essentially insoluble in non-polar solvents. Acetonitrile is strictly required to facilitate the necessary charge-transfer interactions and solubilize the cationic reagent (1)[1].
- Reaction Monitoring: Stir the suspension at room temperature. Monitor the reaction via TLC or LC-MS. The reaction typically reaches completion within 1–2 hours as the enol form continuously attacks the electrophilic N-F bond.
- Workup: Quench the reaction with water (10 mL per mmol). Extract the aqueous layer with ethyl acetate (3 x 15 mL). Wash the combined organic layers with brine, dry over anhydrous Na₂SO₄, and concentrate under reduced pressure.
- Purification: Purify via silica gel flash chromatography to yield the α -fluoro β -ketoester.

Protocol B: Nucleophilic Deoxyfluorination of a Primary Alcohol using XtalFluor-E

This protocol utilizes an exogenous fluoride source to prevent the buildup of basic intermediates, drastically suppressing E2 elimination compared to traditional DAST protocols (4)[4].

- Preparation: Dissolve the primary alcohol (1.0 equiv) in anhydrous dichloromethane (DCM) in a chemically resistant plastic or PTFE-lined vessel.

- Promoter Addition: Add triethylamine trihydrofluoride ($\text{Et}_3\text{N}\cdot 3\text{HF}$, 2.0 equiv) and DBU (1.5 equiv) to the solution at 0 °C.
- Reagent Addition: Introduce XtalFluor-E (1.5 equiv) portion-wise.
 - Causality Check: The alcohol attacks the sulfur center of XtalFluor-E, forming an activated alkoxy-sulfonium intermediate. The exogenous fluoride ($\text{Et}_3\text{N}\cdot 3\text{HF}$) provides the highly nucleophilic F^- , while DBU prevents acidic decomposition. This combination forces the $\text{S}_{\text{N}}2$ displacement before elimination can occur (2)[2].
- Workup: After stirring for 2 hours at room temperature, quench carefully with saturated aqueous NaHCO_3 . Extract with DCM, dry over MgSO_4 , and concentrate.

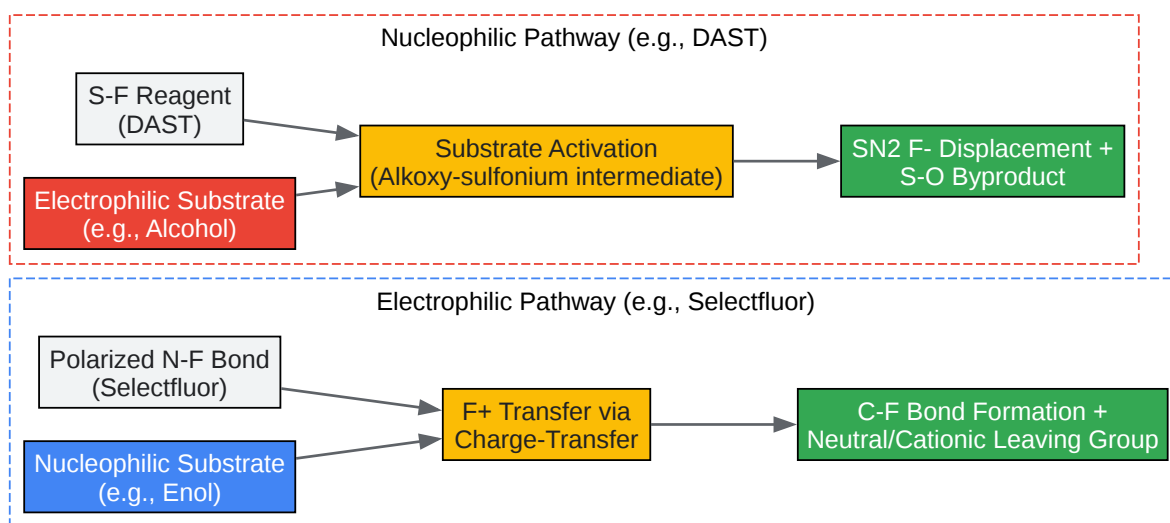

[Click to download full resolution via product page](#)

Caption: Mechanistic divergence between electrophilic F^+ transfer and nucleophilic $\text{S}_{\text{N}}2$ displacement.

References

- Catalytic Fluorination with Modern Fluorinating Agents: Recent Developments and Synthetic Scope - MDPI URL
- Electrophilic NF Fluorinating Agents - ACS Publications URL
- Selective Fluorination of Complex Molecules: Late-Stage Functionalization - ACS Publications URL
- Strategies for Nucleophilic C(sp³)–(Radio)Fluorination - UCLA (The Doyle Group)
- Simpler fluorine chemistry - SCI URL
- A Comparative Guide to Modern Fluorination Agents in Organic Synthesis - Benchchem URL
- Comprehensive Guide to Nucleophilic Fluorination vs.

Need Custom Synthesis?

BenchChem offers custom synthesis for rare earth carbides and specific isotopic labeling.

Email: info@benchchem.com or [Request Quote Online](#).

Sources

- [1. mdpi.com](https://www.mdpi.com) [[mdpi.com](https://www.mdpi.com)]
- [2. alfa-chemistry.com](https://www.alfa-chemistry.com) [[alfa-chemistry.com](https://www.alfa-chemistry.com)]
- [3. doyle.chem.ucla.edu](https://doyle.chem.ucla.edu) [doyle.chem.ucla.edu]
- [4. Simpler fluorine chemistry](https://www.soci.org) [[soci.org](https://www.soci.org)]
- [5. pubs.acs.org](https://pubs.acs.org) [pubs.acs.org]
- [6. pubs.acs.org](https://pubs.acs.org) [pubs.acs.org]
- [7. benchchem.com](https://www.benchchem.com) [[benchchem.com](https://www.benchchem.com)]
- To cite this document: BenchChem. [comparative study of electrophilic vs. nucleophilic fluorination methods]. BenchChem, [2026]. [Online PDF]. Available at: [<https://www.benchchem.com/product/b2859509/docs#comparative-study-of-electrophilic-vs-nucleophilic-fluorination-methods>]

Disclaimer & Data Validity:

The information provided in this document is for Research Use Only (RUO) and is strictly not intended for diagnostic or therapeutic procedures. While BenchChem strives to provide

accurate protocols, we make no warranties, express or implied, regarding the fitness of this product for every specific experimental setup.

Technical Support: The protocols provided are for reference purposes. Unsure if this reagent suits your experiment?

Need Industrial/Bulk Grade? [Request Custom Synthesis Quote](#)

BenchChem

Our mission is to be the trusted global source of essential and advanced chemicals, empowering scientists and researchers to drive progress in science and industry.

Contact

Address: 3281 E Guasti Rd

Ontario, CA 91761, United States

Phone: (601) 213-4426

Email: info@benchchem.com

[Contact our Ph.D. Support Team for a compatibility check](#)