

Application Note: Strategic Functionalization of the 5-Position in 2-Alkoxy-3-Picolines

Author: BenchChem Technical Support Team. **Date:** April 2026

Compound of Interest

Compound Name:	5-Bromo-2-[2-(N,N-dimethylamino)ethoxy]-3-picoline
CAS No.:	1289156-46-2
Cat. No.:	B2858855

[Get Quote](#)

Executive Summary

The 2-alkoxy-3-methylpyridine (2-alkoxy-3-picoline) scaffold is a privileged core in medicinal chemistry, frequently appearing in kinase inhibitors (e.g., p38 MAP kinase, EGFR) and allosteric modulators. Functionalizing the 5-position is critical for expanding Structure-Activity Relationship (SAR) vectors into the "solvent-exposed" regions of binding pockets.

However, this scaffold presents a regioselectivity paradox:

- **Electronic Activation:** The 2-alkoxy group strongly activates the ring, directing ortho and para.
- **Steric/Positional Conflict:** The 3-methyl group blocks the ortho position.
- **Competitive Reactivity:** The benzylic methyl protons (lateral position) are susceptible to radical halogenation or deprotonation, competing with nuclear functionalization.

This guide details two high-fidelity protocols to reliably access the 5-position: Classical Electrophilic Bromination (Electronic Control) and Iridium-Catalyzed C-H Borylation (Steric

Control).

Strategic Analysis: The Regioselectivity Map

To successfully functionalize the 5-position, one must understand the competing forces on the pyridine ring.

Position	Reactivity Profile	Accessibility Challenge
C3 (Methyl)	Lateral Attack: Benzylic protons are acidic () and radical-sensitive.	Risk: Competitive radical bromination or lateral lithiation.
C4	Steric Clash: Located between the C3-Me and C5-H.	Blocked: Hard to access via C-H activation due to flanking substituents.
C5 (Target)	Electronic Sweet Spot: Para to the activating 2-alkoxy group.	Ideal: Most nucleophilic site for EAS; sterically accessible for Ir-catalysis.
C6	Inductive Deactivation: Adjacent to Nitrogen (-position).	Secondary Target: Favored by Directed Ortho Metalation (DoM) if C3 is blocked.

Pathway Visualization

The following diagram illustrates the divergent pathways based on reagent choice.

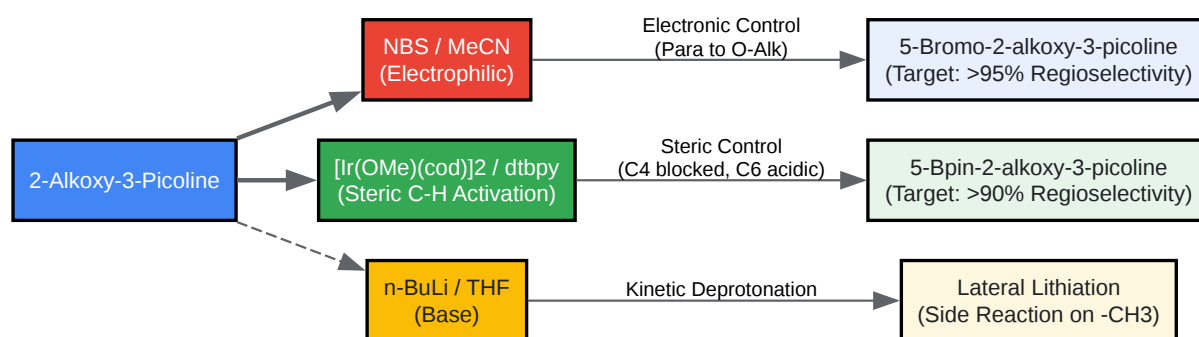

[Click to download full resolution via product page](#)

Caption: Decision tree for functionalization. Electrophilic and Iridium pathways converge on C5, while strong bases risk lateral deprotonation.

Method A: Electrophilic Bromination (Electronic Control)

This is the "workhorse" method. The 2-alkoxy group is a strong Electron Donating Group (EDG). In Electrophilic Aromatic Substitution (EAS), it directs incoming electrophiles to the ortho and para positions. Since the ortho position (C3) is blocked by the methyl group, the C5 position (para) is the exclusive site of reaction.

Protocol 1: Regioselective Bromination with NBS

Why this works: N-Bromosuccinimide (NBS) in polar aprotic solvents (MeCN) provides a controlled source of electrophilic bromine (

), minimizing the radical concentration that would otherwise attack the methyl group.

Materials:

- Substrate: 2-Methoxy-3-methylpyridine (1.0 equiv)
- Reagent: N-Bromosuccinimide (NBS) (1.05 equiv)
- Solvent: Acetonitrile (MeCN) (0.5 M concentration)
- Temperature: 0 °C to Room Temperature (RT)

Step-by-Step Procedure:

- Preparation: Charge a reaction vessel with 2-methoxy-3-methylpyridine (e.g., 10.0 mmol) and MeCN (20 mL). Cool the solution to 0 °C in an ice bath. Crucial: Cooling suppresses radical side reactions.
- Addition: Add NBS (10.5 mmol) portion-wise over 15 minutes. Protect the flask from direct light (wrap in foil) to inhibit radical initiation.

- Reaction: Allow the mixture to warm to RT naturally. Stir for 2–4 hours.
- Monitoring: Monitor by TLC (Hexane/EtOAc 8:1) or LC-MS.[1] The product (5-bromo) is less polar than the starting material. Look for the disappearance of the C5-H signal in NMR (ppm).
- Workup: Concentrate MeCN under reduced pressure. Redissolve the residue in EtOAc and wash with water () and brine ().
- Purification: If necessary, purify via silica gel flash chromatography (0-10% EtOAc in Hexanes).

Expected Yield: 85–95% Data Validation:

- ¹H NMR (CDCl₃): The C6-H proton will appear as a doublet () shifted downfield (ppm) due to the adjacent bromine, distinct from the C4-H (ppm).

Method B: Iridium-Catalyzed C-H Borylation (Steric Control)

For accessing boronic esters directly (avoiding the bromide intermediate), Iridium catalysis is superior. This reaction is governed by sterics, not electronics.

Mechanistic Insight: The active catalyst, generated from and a bipyridine ligand, forms a bulky complex.

- C3: Blocked (Methyl).
- C4: Blocked (Sterically crowded between C3-Me and C5-H).

- C2: Blocked (Alkoxy).
- C6: Sterically accessible, but electronically deactivated (inductive withdrawal of N) and less favored than C5 in 2,3-disubstituted systems.
- C5: The most accessible "active" C-H bond.

Protocol 2: C-H Borylation

Materials:

- Substrate: 2-Methoxy-3-methylpyridine (1.0 mmol)
- Boron Source: Bis(pinacolato)diboron () (0.6 equiv - Note: 0.5 equiv of dimer provides 1 equiv of Boron, slight excess used)
- Catalyst: (1.5 mol%)
- Ligand: dtbpy (4,4'-di-tert-butyl-2,2'-bipyridine) (3.0 mol%)
- Solvent: THF or Hexane (anhydrous)

Step-by-Step Procedure:

- Catalyst Activation: In a glovebox or under Argon, mix (10 mg) and dtbpy (8 mg) in THF (2 mL). The solution should turn dark brown/red, indicating active catalyst formation.
- Reaction Assembly: Add (152 mg, 0.6 mmol) and the pyridine substrate (123 mg, 1.0 mmol) to the catalyst solution.
- Heating: Seal the pressure tube and heat to 80 °C for 16 hours.
- Workup: Cool to RT. Dilute with DCM and pass through a short pad of Celite/Silica to remove the metal catalyst.

- Isolation: Concentrate in vacuo. The residue is often pure enough for Suzuki coupling. If purification is needed, use rapid silica chromatography (deactivates silica with 1% to prevent protodeboronation).

Expected Yield: 75–85% Selectivity: Typically >10:1 favoring C5 over C4/C6.

Comparative Data & Troubleshooting

Regioselectivity Outcomes^{[2][3][4][5][6]}

Method	Primary Product	Major Impurity	Cause of Impurity
NBS / MeCN	5-Bromo (>95%)	3-(Bromomethyl)pyridine	Radical mechanism (light/heat).
Ir-Catalyzed	5-Bpin (>90%)	4-Bpin isomer	Small steric difference if Alkoxy group is small (e.g., -OMe).
n-BuLi (DoM)	Lateral-Li	6-Li species	Acidity of benzylic methyl protons > Ring protons.

Troubleshooting "Lateral" Side Reactions

If you observe bromination on the methyl group (formation of

-):
- Switch Solvent: Change from MeCN to AcOH (Acetic Acid). The proton source quenches radical chains.
 - Exclude Light: Wrap the flask in aluminum foil.
 - Add Radical Scavenger: Add 1 mol% BHT (Butylated hydroxytoluene) to the reaction mixture.

References

- Regioselective Bromination of 2-Alkoxy-3-picolines
 - Title: Regioselective bromination: Synthesis of brominated methoxyquinolines (and pyridine analogs).[2]
 - Source: Tetrahedron, 2017.[2]
 - URL:[[Link](#)][2]
- Iridium-Catalyzed Borylation Selectivity
 - Title: Iridium-Catalyzed C-H Borylation of Heteroarenes: Scope, Regioselectivity, and Application to Late-Stage Functionaliz
 - Source: J. Am. Chem. Soc., 2014.[3]
 - URL:[[Link](#)]
- Synthesis of 5-Bromo-2-methoxy-3-methylpyridine (Commercial Precedent)
 - Title: 5-Bromo-2-methoxy-3-methylpyridine Product Page (CAS 760207-87-2).[4]
 - Source: Fluorochem.[5]
- General Protocol for Pyridine Borylation
 - Title: Iridium-catalyzed C-H borylation of pyridines.[3]
 - Source: Organic Syntheses, 2015.
 - URL:[[Link](#)]

Need Custom Synthesis?

BenchChem offers custom synthesis for rare earth carbides and specific isotopic labeling.

Email: info@benchchem.com or [Request Quote Online](#).

Sources

- [1. pdf.benchchem.com \[pdf.benchchem.com\]](https://pdf.benchchem.com)
- [2. Regioselective bromination: Synthesis of brominated methoxyquinolines \[agris.fao.org\]](https://agris.fao.org)
- [3. chemrxiv.org \[chemrxiv.org\]](https://chemrxiv.org)
- [4. echemi.com \[echemi.com\]](https://echemi.com)
- [5. fluorochem.co.uk \[fluorochem.co.uk\]](https://fluorochem.co.uk)
- To cite this document: BenchChem. [Application Note: Strategic Functionalization of the 5-Position in 2-Alkoxy-3-Picolines]. BenchChem, [2026]. [Online PDF]. Available at: [\[https://www.benchchem.com/product/b2858855/docs#application-note-strategic-functionalization-of-the-5-position-in-2-alkoxy-3-picolines\]](https://www.benchchem.com/product/b2858855/docs#application-note-strategic-functionalization-of-the-5-position-in-2-alkoxy-3-picolines)

Disclaimer & Data Validity:

The information provided in this document is for Research Use Only (RUO) and is strictly not intended for diagnostic or therapeutic procedures. While BenchChem strives to provide accurate protocols, we make no warranties, express or implied, regarding the fitness of this product for every specific experimental setup.

Technical Support: The protocols provided are for reference purposes. Unsure if this reagent suits your experiment?

Need Industrial/Bulk Grade? [Request Custom Synthesis Quote](#)

BenchChem

Our mission is to be the trusted global source of essential and advanced chemicals, empowering scientists and researchers to drive progress in science and industry.

Contact

Address: 3281 E Guasti Rd

Ontario, CA 91761, United States

Phone: (601) 213-4426

Email: info@benchchem.com

Contact our Ph.D. Support Team for a compatibility check