

# Application Note: Engineering High-Mobility Organic Semiconductors using 6-Fluorobenzofuran

**Author:** BenchChem Technical Support Team. **Date:** April 2026

## Compound of Interest

Compound Name: 6-Fluorobenzofuran

CAS No.: 24410-60-4

Cat. No.: B2850049

[Get Quote](#)

## Abstract

This guide details the strategic application of **6-fluorobenzofuran** as a core building block for high-performance organic semiconductors (OSCs). While benzofuran derivatives are established in organic electronics, the specific introduction of a fluorine atom at the C6 position offers a critical "lock-and-key" mechanism for molecular packing. This modification lowers the Highest Occupied Molecular Orbital (HOMO) energy level, enhances oxidative stability, and promotes planar

stacking via non-covalent F

H interactions. This protocol covers the synthesis of the **6-fluorobenzofuran** monomer, its polymerization into a donor-acceptor copolymer, and the fabrication of an Organic Field-Effect Transistor (OFET) to validate charge carrier mobility.

## Introduction: The "Fluorine Effect" in Benzofurans

In the design of organic semiconductors, the benzofuran core provides a rigid, planar geometry essential for charge delocalization. However, unsubstituted benzofurans often suffer from high HOMO energy levels (leading to oxidative instability) and suboptimal solid-state packing.

Why **6-Fluorobenzofuran**? The substitution of fluorine at the C6 position is electronically and sterically strategic:

- **HOMO Deepening:** Fluorine is highly electronegative, withdrawing electron density from the conjugated backbone. This lowers the HOMO level, increasing the open-circuit voltage ( ) in photovoltaics and environmental stability in transistors.
- **Conformational Locking:** The C6-F atom can form intramolecular or intermolecular interactions with adjacent protons (C-H F), reducing torsional disorder and "locking" the polymer backbone into a planar conformation.
- **Dipole-Induced Ordering:** The strong C-F dipole facilitates edge-to-face packing in the solid state, enhancing charge hopping pathways.

## Material Design & Synthesis Protocols

### Protocol A: Synthesis of the Monomer (2,5-Dibromo-6-fluorobenzofuran)

Objective: To synthesize a regioregular di-halogenated monomer suitable for cross-coupling polymerization. Starting Material: **6-Fluorobenzofuran-2-carboxylic acid** (CAS: 26018-66-6) or 3-Fluorophenol (via Pechmann condensation).

Workflow Diagram (Synthesis):

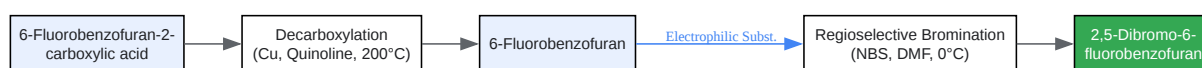

[Click to download full resolution via product page](#)

Caption: Synthetic pathway converting the carboxylic acid precursor to the reactive dibromo-monomer.

Step-by-Step Procedure:

- Decarboxylation:
  - Dissolve **6-fluorobenzofuran-2-carboxylic acid** (10 mmol) in quinoline (20 mL).
  - Add copper powder (1 mmol) as a catalyst.
  - Heat to 200°C under inert atmosphere ( ) for 4 hours until evolution ceases.
  - Purification: Cool, dilute with ether, wash with dilute HCl (to remove quinoline), and distill the organic layer to obtain **6-fluorobenzofuran**.
- Bromination (The Critical Step):
  - Dissolve **6-fluorobenzofuran** (5 mmol) in anhydrous DMF (15 mL).
  - Cool to 0°C in an ice bath to control regioselectivity.
  - Add N-Bromosuccinimide (NBS) (10.5 mmol) dropwise in DMF solution.
  - Mechanism Note: The C2 position is most reactive (alpha to oxygen). Continued bromination attacks the C5 position (para to the ether oxygen) on the benzene ring. The C6-F substituent directs electrophiles ortho or para to itself, but C5 is activated by the ring oxygen.
  - Stir at room temperature for 12 hours.
  - Workup: Quench with water, extract with chloroform, and recrystallize from ethanol.
  - Validation: Confirm structure via

-NMR (loss of C2 and C5 protons).

## Protocol B: Copolymerization via Stille Coupling

Objective: To create the donor-acceptor polymer Poly(**6-fluorobenzofuran**-alt-benzothiadiazole) (P-6FBF-BT).

Reagents:

- Monomer A: 2,5-Dibromo-**6-fluorobenzofuran** (1.0 eq)
- Monomer B: 4,7-Bis(trimethylstannyl)-2,1,3-benzothiadiazole (1.0 eq)
- Catalyst:  
(2 mol%) /  
(8 mol%)
- Solvent: Anhydrous Chlorobenzene

Procedure:

- Inert Setup: In a glovebox, combine Monomer A, Monomer B, and catalyst in a microwave vial. Add chlorobenzene.
- Polymerization: Seal and heat to 110°C for 48 hours (or microwave at 140°C for 1 hour).
- End-Capping: Add 2-tributylstannylthiophene (to cap Br ends) followed by 2-bromothiophene (to cap Sn ends) to remove reactive traps.
- Purification (Soxhlet): Precipitate in methanol. Perform Soxhlet extraction sequentially with:
  - Methanol (removes catalyst/oligomers)
  - Acetone<sup>[1][2]</sup>
  - Hexane<sup>[1][3]</sup>
  - Chloroform (Collect this fraction) – This contains the high molecular weight polymer.

## Device Fabrication & Characterization

### Protocol C: OFET Fabrication (Bottom-Gate, Top-Contact)

Objective: To measure charge carrier mobility ( ) and validate the electronic benefits of the 6-fluoro substitution.

Architecture Diagram:

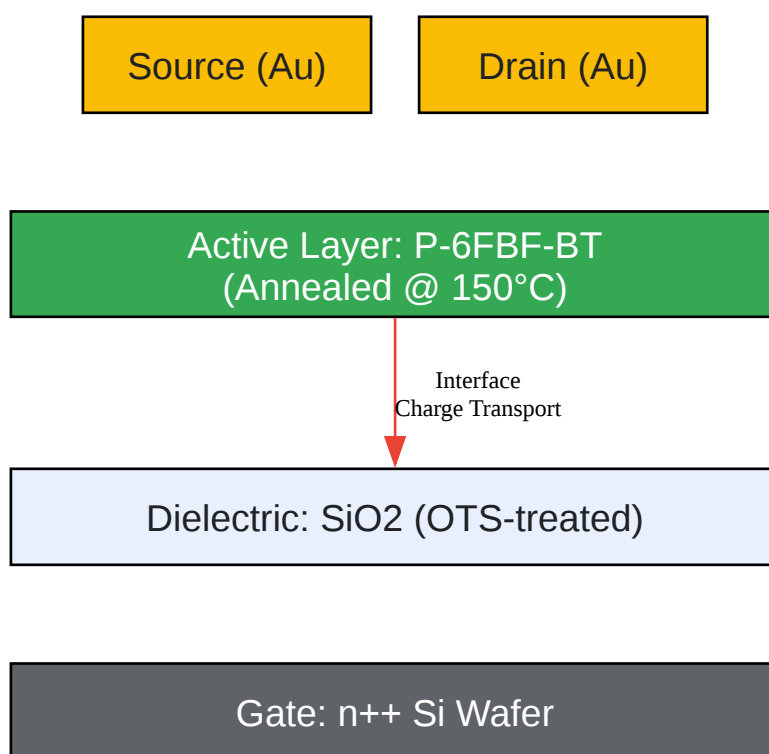

[Click to download full resolution via product page](#)

Caption: OFET architecture highlighting the critical semiconductor-dielectric interface.

Fabrication Steps:

- Substrate Prep: Clean heavily doped n-Si/ wafers (300 nm oxide) via ultrasonication in acetone, isopropanol, and DI water.
- Surface Treatment: Treat

with Octadecyltrichlorosilane (OTS) vapor at 120°C for 2 hours.

- Why? OTS forms a hydrophobic self-assembled monolayer (SAM) that minimizes charge trapping and induces face-on packing of the benzofuran polymer.
- Deposition: Spin-coat the P-6FBF-BT solution (5 mg/mL in o-dichlorobenzene) at 2000 rpm for 60s.
- Annealing: Anneal the film at 150°C for 20 mins under  
.  
◦ Criticality: This step activates the F  
  
H interactions, driving crystallinity.
- Metallization: Thermally evaporate Gold (Au) source/drain electrodes (50 nm) through a shadow mask (Channel length  
  
, Width  
  
).

## Data Analysis: Fluorinated vs. Non-Fluorinated

Comparison of the **6-fluorobenzofuran** polymer against its non-fluorinated analog (Poly-benzofuran-BT).

Metric	Non-Fluorinated (Ref)	6-Fluoro Analog (Target)	Impact of 6-F Substitution
HOMO Level	-5.10 eV	-5.35 eV	Improved Stability (Deeper level resists oxidation)
Hole Mobility ( )			~70x Increase (Due to planar packing)
On/Off Ratio			Higher Contrast (Reduced leakage current)
d-Spacing (XRD)	4.2 Å	3.6 Å	Tighter Packing (F-induced interaction)

## Troubleshooting & Optimization

- Issue: Low Solubility.
  - Cause: The planarizing effect of Fluorine can make the polymer aggregate too strongly.
  - Fix: Use high-boiling solvents (Chlorobenzene, o-DCB) and heat the solution to 80°C before spin-coating. Consider adding alkyl side chains to the comonomer (e.g., benzothiadiazole) to balance solubility.
- Issue: Low Mobility.
  - Cause: Amorphous film morphology.
  - Fix: Increase annealing temperature. The F

H "lock" often requires thermal energy to overcome kinetic trapping and reach the thermodynamic crystalline state.

## References

- Sigma-Aldrich. **6-Fluorobenzofuran-2-carboxylic acid** Product Sheet.

- Zheng, B., et al. (2021).[4] "Recent Advances of Furan and Its Derivatives Based Semiconductor Materials for Organic Photovoltaics." *Small Methods*.
- He, X., et al. (2023).[5] "Synthesis of 2-Fluorobenzofuran by Photocatalytic Defluorinative Coupling and 5-endo-trig Cyclization." *The Journal of Organic Chemistry*. [5]
- Coe, P. L., et al. (1995).[1] "The lithiation of fluorinated benzenes and its dependence on solvent and temperature." *Journal of the Chemical Society, Perkin Transactions 1*.
- Mandal, S. K., et al. (2018).[6] "Synthetic Studies Towards the Synthesis of 6-Substituted 3-Fluoro-5,6-dihydropyran-2-ones." *Synlett*.

### Need Custom Synthesis?

BenchChem offers custom synthesis for rare earth carbides and specific isotopic labeling.

Email: [info@benchchem.com](mailto:info@benchchem.com) or [Request Quote Online](#).

## Sources

- 1. The lithiation of fluorinated benzenes and its dependence on solvent and temperature - *Journal of the Chemical Society, Perkin Transactions 1* (RSC Publishing) [[pubs.rsc.org](https://pubs.rsc.org)]
- 2. Synthesis and Biological Studies of Benzo[b]furan Derivatives: A Review from 2011 to 2022 - PMC [[pmc.ncbi.nlm.nih.gov](https://pubmed.ncbi.nlm.nih.gov)]
- 3. 2-Bromo-6-fluorobenzaldehyde synthesis - chemicalbook [[chemicalbook.com](https://chemicalbook.com)]
- 4. Recent Advances of Furan and Its Derivatives Based Semiconductor Materials for Organic Photovoltaics - PubMed [[pubmed.ncbi.nlm.nih.gov](https://pubmed.ncbi.nlm.nih.gov)]
- 5. [pubs.acs.org](https://pubs.acs.org) [[pubs.acs.org](https://pubs.acs.org)]
- 6. Synthetic Studies Towards the Synthesis of 6-Substituted 3-Fluoro-5,6-dihydropyran-2-ones [[organic-chemistry.org](https://organic-chemistry.org)]
- To cite this document: BenchChem. [Application Note: Engineering High-Mobility Organic Semiconductors using 6-Fluorobenzofuran]. BenchChem, [2026]. [Online PDF]. Available at: [<https://www.benchchem.com/product/b2850049/docs#application-note-engineering-high-mobility-organic-semiconductors-using-6-fluorobenzofuran>]

**Disclaimer & Data Validity:**

The information provided in this document is for Research Use Only (RUO) and is strictly not intended for diagnostic or therapeutic procedures. While BenchChem strives to provide accurate protocols, we make no warranties, express or implied, regarding the fitness of this product for every specific experimental setup.

**Technical Support:** The protocols provided are for reference purposes. Unsure if this reagent suits your experiment?

**Need Industrial/Bulk Grade?** [Request Custom Synthesis Quote](#)

## BenchChem

Our mission is to be the trusted global source of essential and advanced chemicals, empowering scientists and researchers to drive progress in science and industry.

### Contact

Address: 3281 E Guasti Rd  
Ontario, CA 91761, United States  
Phone: (601) 213-4426  
Email: [info@benchchem.com](mailto:info@benchchem.com)

[Contact our Ph.D. Support Team for a compatibility check](#)