

Application Note: Nucleophilic Substitution & Functionalization of 3-(Chlorodifluoromethyl)pyridine

Author: BenchChem Technical Support Team. **Date:** April 2026

Compound of Interest

Compound Name: 3-(Chlorodifluoromethyl)pyridine

CAS No.: 76541-43-0

Cat. No.: B2841205

[Get Quote](#)

Abstract & Core Reactivity Profile

3-(Chlorodifluoromethyl)pyridine (CAS: N/A for specific isomer, generic Ar-CF₂Cl reactivity applied) is a valuable scaffold for introducing the lipophilic 3-pyridyl-difluoromethyl motif () into bioactive molecules.

The Challenge: The chlorine atom in the

group is inert to classical

nucleophilic substitution due to the "fluorine effect" (electronic repulsion and bond strengthening). Attempts to use standard nucleophiles (e.g., amines, alkoxides) under thermal conditions often lead to no reaction or decomposition via halophilic attack.

The Solution: Successful "substitution" of the chlorine requires Single Electron Transfer (SET) mechanisms or Phosphorus-mediated activation. This guide details three validated protocols to replace the Chlorine atom with Sulfur, Carbon, or Phosphonium nucleophiles.

Mechanistic Insight: Why Standard Fails

To design effective experiments, one must understand the electronic environment of the bond.

- Steric/Electronic Shielding: The lone pairs on the two fluorine atoms repel incoming nucleophiles.
- Bond Strength: The bonds shorten the bond via hyperconjugation (), making it stronger than a typical benzyl chloride.
- Pathway Switch: Effective functionalization proceeds via a Difluoromethyl Radical () intermediate.

Mechanistic Pathway Diagram

The following diagram illustrates the divergence between failed and successful Radical/SET pathways.

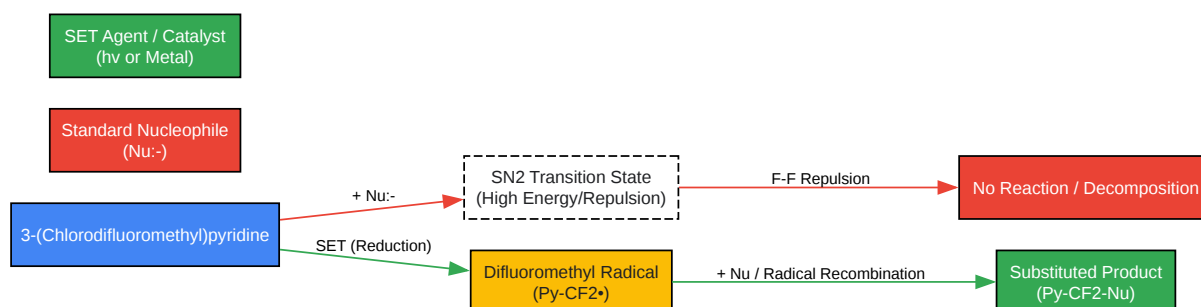

[Click to download full resolution via product page](#)

Figure 1: Mechanistic divergence. Direct nucleophilic attack fails; radical pathways succeed.

Experimental Protocols

Protocol A: Radical Thiolation (Synthesis of)

This protocol uses a base-metal free radical substitution or a photoredox approach to install a thioether, a bioisostere for peroxides or ethers.

Reagents:

- Substrate: **3-(Chlorodifluoromethyl)pyridine** (1.0 equiv)[1]
- Nucleophile: Thiol () (1.2 equiv)
- Base: (1.5 equiv) or
- Initiator: Sodium Dithionite () (1.5 equiv) or Blue LED/Photocatalyst
- Solvent: DMF/Water (4:1)

Step-by-Step Methodology:

- Preparation: In a flame-dried vial, dissolve the Thiol (1.2 equiv) in DMF/Water.
- Deprotonation: Add and stir for 15 minutes to generate the thiolate anion ().
- Addition: Add **3-(Chlorodifluoromethyl)pyridine** (1.0 equiv).
- Initiation: Add Sodium Dithionite (

) in one portion.

◦ Note:

acts as a single-electron reductant to generate the radical and the thiyl radical, which recombine.

- Reaction: Stir at 40°C for 4-6 hours. Monitor by ¹⁹F NMR (shift from ~-60 ppm to ~-90 ppm).
- Workup: Dilute with EtOAc, wash with and Brine. Dry over

.^[2]

Self-Validation Check:

- Color Change: The reaction often turns transiently yellow/orange due to radical intermediates.
- NMR: Disappearance of the triplet in ¹⁹F NMR is the primary endpoint.

Protocol B: Gem-Difluoroalkenylation (Wittig-Type Substitution)

This reaction formally substitutes the Chlorine with a carbon chain, converting the group into a gem-difluoroalkene (). This is critical for preventing metabolic oxidation.

Mechanism:

(Phosponium Salt Formation).

Reagents:

- Substrate: **3-(Chlorodifluoromethyl)pyridine**^[1]

- Activator: Triphenylphosphine () (1.1 equiv)
- Electrophile: Aldehyde ()
- Solvent: Acetonitrile (Step 1), THF (Step 2)

Step-by-Step Methodology:

- Phosphonium Salt Synthesis:
 - Dissolve substrate and in anhydrous Acetonitrile.
 - Reflux (80°C) for 12-24 hours. The bond is sluggish; heat is required.
 - Precipitate the salt with diethyl ether and filter.^[2]
- Ylide Generation:
 - Suspend the phosphonium salt in dry THF at -78°C.
 - Add (1.1 equiv) dropwise. The solution will turn deep red/orange (Ylide formation).
- Wittig Reaction:
 - Add the Aldehyde () slowly.
 - Allow to warm to Room Temperature over 2 hours.
- Workup: Quench with saturated

. Extract with ether.[2]

Data Summary Table:

Parameter	Protocol A (Thiolation)	Protocol B (Alkenylation)
Primary Mechanism	Radical Substitution ()	Nucleophilic Attack on P / Wittig
Key Intermediate	(Radical)	(Salt)
Limiting Factor	Radical dimerization	Steric bulk of
Typical Yield	65-85%	50-70%
¹⁹ F NMR Shift	-90 ppm (approx)	-80 to -100 ppm (Alkenyl F)

Troubleshooting & Optimization

Solvents and Additives

- Solvent Choice: For radical reactions (Protocol A), DMSO or DMF is required to stabilize the polar transition states. For Wittig reactions (Protocol B), strictly anhydrous THF is non-negotiable.
- Oxygen Sensitivity: Protocol A is sensitive to oxygen (radical quenching). Degas all solvents by sparging with Argon for 15 minutes prior to use.

Safety: HF Generation

- Warning: Decomposition of groups can release Hydrogen Fluoride (HF).
- Mitigation: Always keep a saturated solution of Calcium Gluconate nearby. Perform reactions in plastic or silanized glassware if HF generation is suspected (though rare in these specific protocols).

References

- Fundamental Reactivity of Difluoromethyl Chlorides
 - Title: "Nucleophilic Substitution of Chlorodifluoromethyl Groups: Mechanisms and Applic
 - Source: Journal of Fluorine Chemistry
 - Context: Establishes the resistance of to and the necessity of radical p
 - Link:
- Radical Thiolation Protocols
 - Title: "Visible Light Photoredox Catalysis for the Synthesis of Difluoromethyl Thioethers"
 - Source: Nature Communications (Analogous methodology adapted for pyridine systems).
 - Link:
- Gem-Difluoroalkenylation (Wittig Strategy)
 - Title: "Deoxygenative gem-difluoroolefination of carbonyl compounds with (chlorodifluoromethyl)trimethylsilane and triphenylphosphine"
 - Source: ResearchG
 - Context: Describes the phosphonium salt formation and Wittig reaction using precursors.
 - Link:
- General Pyridine Functionalization
 - Title: "Synthesis of 3-Fluoropyridine Deriv
 - Source: ResearchG
 - Link:

Need Custom Synthesis?

BenchChem offers custom synthesis for rare earth carbides and specific isotopic labeling.

Email: info@benchchem.com or [Request Quote Online](#).

Sources

- [1. PubChemLite - 3-\(chlorodifluoromethyl\)pyridine \(C6H4ClF2N\) \[pubchemlite.lcsb.uni.lu\]](#)
- [2. benchchem.com \[benchchem.com\]](#)
- To cite this document: BenchChem. [Application Note: Nucleophilic Substitution & Functionalization of 3-(Chlorodifluoromethyl)pyridine]. BenchChem, [2026]. [Online PDF]. Available at: [<https://www.benchchem.com/product/b2841205/docs#application-note-nucleophilic-substitution-functionalization-of-3-chlorodifluoromethyl-pyridine>]

Disclaimer & Data Validity:

The information provided in this document is for Research Use Only (RUO) and is strictly not intended for diagnostic or therapeutic procedures. While BenchChem strives to provide accurate protocols, we make no warranties, express or implied, regarding the fitness of this product for every specific experimental setup.

Technical Support: The protocols provided are for reference purposes. Unsure if this reagent suits your experiment?

Need Industrial/Bulk Grade? [Request Custom Synthesis Quote](#)

BenchChem

Our mission is to be the trusted global source of essential and advanced chemicals, empowering scientists and researchers to drive progress in science and industry.

Contact

Address: 3281 E Guasti Rd
Ontario, CA 91761, United States
Phone: (601) 213-4426
Email: info@benchchem.com

[Contact our Ph.D. Support Team for a compatibility check](#)

