

# Comparative Guide: Chloroacetamido vs. Bromoacetamido Benzoate Reactivity

**Author:** BenchChem Technical Support Team. **Date:** April 2026

## Compound of Interest

Compound Name: *Methyl 2-(2-chloroacetamido)-3-methylbenzoate*

CAS No.: 77093-79-9

Cat. No.: B2839054

[Get Quote](#)

## Executive Summary

The Core Trade-off: In the design of Targeted Covalent Inhibitors (TCIs) and Activity-Based Probes (ABPP), the choice between chloroacetamido and bromoacetamido warheads represents a fundamental trade-off between kinetic efficiency and chemoselectivity.

- Chloroacetamido Benzoates: Exhibit "Goldilocks" reactivity. They are sufficiently electrophilic to modify catalytic cysteines when positioned by a binding scaffold (proximity-driven) but possess high intrinsic stability and low off-target reactivity toward solvent-exposed nucleophiles.
- Bromoacetamido Benzoates: Are significantly more reactive (10–100x faster intrinsic kinetics). They are preferred when the target cysteine has a high pKa (low nucleophilicity) or when the reversible binding affinity ( ) is weak. However, this comes at the cost of plasma instability and increased promiscuity (alkylation of Histidine/Lysine).

## Mechanistic Foundation & Chemical Physics

Both warheads operate via an

(Substitution Nucleophilic Bimolecular) mechanism. The nucleophilic thiolate (

) of a cysteine residue attacks the

-carbon of the acetamide, displacing the halogen leaving group.

### The Leaving Group Effect

The reactivity difference is dictated by the carbon-halogen bond strength and the stability of the leaving halide ion.

- Bond Energy:

( $-81$  kcal/mol) >

( $-68$  kcal/mol).

- Leaving Group Ability:

is a weaker base and more stable anion than

, lowering the activation energy (

) for the transition state.

### The Benzoate Scaffold Influence

In "acetamido benzoates," the amide nitrogen is attached to a phenyl ring (an anilide). The aromatic ring pulls electron density from the nitrogen lone pair. While the primary reaction site is the

-carbon, the electronic nature of the benzoate scaffold (often electron-withdrawing) can slightly enhance the electrophilicity of the warhead compared to aliphatic acetamides.

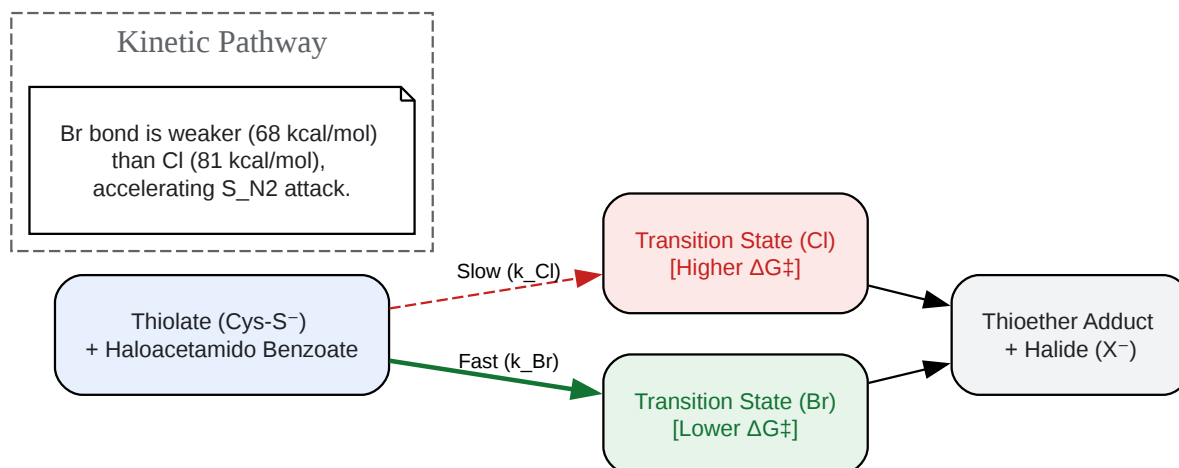

[Click to download full resolution via product page](#)

Figure 1: Reaction coordinate comparison. The Bromo-analogue traverses a lower energy transition state, resulting in faster kinetics (

).

## Kinetic Profiling & Performance Data

The following data summarizes the performance characteristics derived from standard glutathione (GSH) reactivity assays and protein labeling experiments.

### Table 1: Comparative Performance Metrics

Feature	Chloroacetamido Benzoate	Bromoacetamido Benzoate
Intrinsic Reactivity ( )	Low ( )	High ( )
Leaving Group Ability	Moderate ( )	Good ( )
Cysteine Selectivity	High (Cys specific)	Moderate (Cys > His/Lys)
Plasma Stability ( )	High (>24 hours)	Low (<4 hours, susceptible to hydrolysis)
Target Application	Proximity-enabled labeling (High affinity binders)	Low affinity binders or "hard-to-hit" cryptic cysteines
Metabolic Liability	Low	High (Rapid GSH depletion)

\*Values are representative approximations for GSH reactivity at pH 7.4. Actual rates depend on the specific benzoate substitution pattern.

## The Selectivity/Reactivity Paradox

- Chloro: Requires the inhibitor to bind tightly ( ) to the protein to orient the warhead perfectly for reaction ( ). If the inhibitor does not bind, the warhead is too slow to react with random cysteines. Result: High on-target specificity.
- Bromo: Reacts rapidly.<sup>[1]</sup> Even transient, non-specific collisions can lead to covalent modification. Result: Higher background noise in proteomic profiling (ABPP).

## Experimental Protocol: Intrinsic Reactivity Assay (GSH)

To objectively select between Cl and Br variants, you must determine the intrinsic chemical reactivity (

). This protocol uses Glutathione (GSH) as a surrogate nucleophile.[2]

## Workflow Overview

- Incubation: Compound + Excess GSH.
- Monitoring: Time-course sampling via LC-MS.
- Calculation: Pseudo-first-order kinetics.

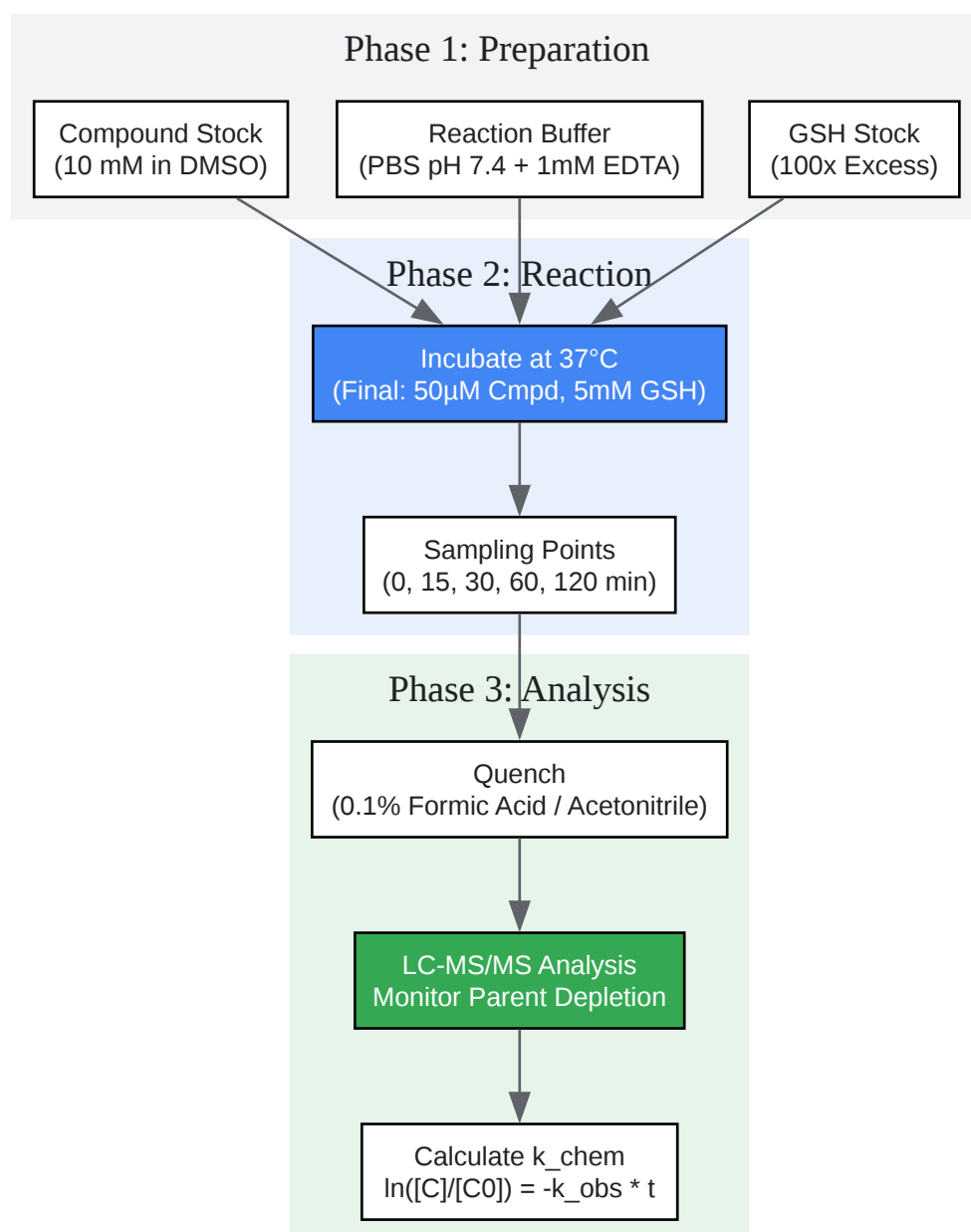

[Click to download full resolution via product page](#)

Figure 2: Standardized Glutathione (GSH) Reactivity Assay Workflow.

## Step-by-Step Methodology

- Buffer Preparation: Prepare 50 mM Phosphate Buffer (pH 7.4) containing 1 mM EDTA (to chelate metals that catalyze auto-oxidation of thiols).
- Reaction Mix:
  - Dilute the Benzoate test compound to 50  $\mu$ M (final) in the buffer. Ensure DMSO concentration is <1%.
  - Add L-Glutathione (reduced) to a final concentration of 5 mM (100-fold excess). This ensures pseudo-first-order conditions.<sup>[2]</sup>
  - Control: Run a parallel sample with compound only (no GSH) to assess hydrolytic stability.
- Incubation: Incubate at 37°C in a thermomixer.
- Sampling: At defined intervals (e.g., 0, 10, 30, 60, 120, 240 min), remove 50  $\mu$ L aliquots.
- Quenching: Immediately add 50  $\mu$ L of ice-cold Acetonitrile + 0.1% Formic Acid to stop the reaction and precipitate salts.
- Analysis: Centrifuge (10,000 x g, 5 min) and inject supernatant onto an LC-MS (Reverse Phase C18).
- Data Processing:
  - Plot the natural log of the remaining parent compound peak area versus time.
  - The slope of the line is
  - Calculate intrinsic reactivity:

**Validation Criteria:**

- The plot of  
  
vs. Time must be linear (  
  
).
- The "No GSH" control must show <10% degradation over the assay duration (crucial for Bromo compounds).

**Decision Matrix: When to use which?**

Scenario	Recommended Warhead	Rationale
Early Hit Discovery	Chloroacetamido	Prioritize selectivity. If a hit is found, it is likely a true binder, not a promiscuous alkylator.
Weak Binder ( )	Bromoacetamido	The residence time of the scaffold is short; a faster reaction rate ( ) is needed to "catch" the cysteine before dissociation.
High pKa Cysteine	Bromoacetamido	If the target Cys is not activated (high pKa), the stronger electrophile (Br) is required to drive the reaction.
In Vivo / Animal Studies	Chloroacetamido	Bromo-analogs often fail in vivo due to rapid clearance by plasma GSH and albumin, leading to poor bioavailability.
Fragment Screening	Chloroacetamido	Fragments have low affinity. Using Br leads to too many false positives. Cl ensures only proximity-driven hits are detected.

## References

- Singh, J., et al. (2011). "The resurgence of covalent drugs." *Nature Reviews Drug Discovery*, 10, 307–317. [Link](#)
- Gehringer, M., & Laufer, S. A. (2019). "Emerging and Re-Emerging Warheads for Targeted Covalent Inhibitors: Applications in Medicinal Chemistry and Chemical Biology." *Journal of Medicinal Chemistry*, 62(12), 5673–5724. [Link](#)

- Backus, K. M., et al. (2016). "Proteome-wide covalent ligand discovery in native biological systems." *Nature*, 534, 570–574. [Link](#)
- Åkerfeldt, K. S., et al. (2011). "Kinetic Analysis of the Reaction of Bromoacetylated Peptides with Thiols." *Journal of the American Chemical Society*. (Foundational kinetic comparisons of haloacetamides).
- Cravatt, B. F., et al. (2008). "Activity-based protein profiling: from enzyme chemistry to proteomic chemistry." *Annual Review of Biochemistry*, 77, 383-414. [Link](#)

### Need Custom Synthesis?

BenchChem offers custom synthesis for rare earth carbides and specific isotopic labeling.

Email: [info@benchchem.com](mailto:info@benchchem.com) or [Request Quote Online](#).

## Sources

- [1. Using Protein-Confined Proximity to Determine Chemical Reactivity - PMC \[pmc.ncbi.nlm.nih.gov\]](#)
- [2. Refining covalent warhead reactivity: A new look at GSH reactivity assays - X-Chem \[x-chemrx.com\]](#)
- To cite this document: BenchChem. [Comparative Guide: Chloroacetamido vs. Bromoacetamido Benzoate Reactivity]. BenchChem, [2026]. [Online PDF]. Available at: [\[https://www.benchchem.com/product/b2839054/docs#comparative-guide-chloroacetamido-vs-bromoacetamido-benzoate-reactivity\]](https://www.benchchem.com/product/b2839054/docs#comparative-guide-chloroacetamido-vs-bromoacetamido-benzoate-reactivity)

---

### Disclaimer & Data Validity:

The information provided in this document is for Research Use Only (RUO) and is strictly not intended for diagnostic or therapeutic procedures. While BenchChem strives to provide accurate protocols, we make no warranties, express or implied, regarding the fitness of this product for every specific experimental setup.

**Technical Support:** The protocols provided are for reference purposes. Unsure if this reagent suits your experiment?

**Need Industrial/Bulk Grade?** [Request Custom Synthesis Quote](#)

## BenchChem

Our mission is to be the trusted global source of essential and advanced chemicals, empowering scientists and researchers to drive progress in science and industry.

### Contact

Address: 3281 E Guasti Rd  
Ontario, CA 91761, United States  
Phone: (601) 213-4426  
Email: [info@benchchem.com](mailto:info@benchchem.com)

[Contact our Ph.D. Support Team for a compatibility check](#)