

Comprehensive Guide: 4-Methoxythiophene-2-Boronic Acid Pinacol Ester

Author: BenchChem Technical Support Team. **Date:** May 2026

Compound of Interest

Compound Name:	(4-Methoxythiophen-2-yl)boronic acid
CAS No.:	1321901-82-9
Cat. No.:	B2837203

[Get Quote](#)

Executive Summary

4-Methoxythiophene-2-boronic acid pinacol ester (often abbreviated as 4-OMe-2-Th-Bpin) is a specialized organoboron building block critical for modern medicinal chemistry and materials science. As an electron-rich heteroaryl boronate, it serves as a robust partner in Suzuki-Miyaura cross-coupling reactions, enabling the introduction of the 4-methoxythiophene moiety—a valuable bioisostere for substituted phenyl rings or electron-donating components in organic semiconductors.

This guide details the structural nuances, regioselective synthesis strategies (Ir-catalyzed C–H borylation vs. Lithiation-Blocking), and practical handling protocols required to maximize yield and stability.

Structural Analysis & Properties

Chemical Identity

- IUPAC Name: 4-methoxy-2-(4,4,5,5-tetramethyl-1,3,2-dioxaborolan-2-yl)thiophene

- Molecular Formula: C₁₁H₁₇BO₃S
- Molecular Weight: ~240.13 g/mol
- Core Scaffold: Thiophene ring substituted with a methoxy group (-OMe) at position 4 and a pinacol boronate (-Bpin) at position 2.

Electronic & Steric Profile

The thiophene ring is inherently electron-rich. The addition of a methoxy group at the C4 position further increases electron density via resonance (+M effect), making the C2 position highly nucleophilic but also susceptible to protodeboronation (loss of the boron group) under acidic or forcing conditions.

- Regiochemistry Note: This molecule is the functional equivalent of 3-methoxythiophene functionalized at the C5 position. (Renumbering: S=1, Bpin=2 OMe=4).
- Stability: The pinacol ester provides steric bulk and hydrolytic stability compared to the free boronic acid, facilitating purification and storage.

Synthesis Protocols

The synthesis of 4-methoxythiophene-2-boronic acid pinacol ester presents a classic regioselectivity challenge. The precursor, 3-methoxythiophene, has two active

-positions: C2 (ortho to OMe) and C5 (meta to OMe).

Method A: Iridium-Catalyzed C–H Borylation (Recommended)

This method leverages steric control to selectively borylate the less hindered C5 position (which becomes C2 in the final product).

- Mechanism: The active catalyst, typically an Ir(III)-trisboryl species generated from
and

, reacts preferentially at the least sterically hindered C–H bond.

- Selectivity: The C2 position is flanked by the sulfur atom and the methoxy group, creating significant steric crowding. The C5 position is flanked only by sulfur and a hydrogen atom, making it the kinetic product.

Protocol:

- Reagents: 3-methoxythiophene (1.0 equiv),
(0.55 equiv),
(1.5 mol%),
(3 mol%).
- Solvent: Hexane or MTBE (anhydrous).
- Conditions: Heat at 60–80°C for 4–16 hours under inert atmosphere ().
- Workup: Concentrate in vacuo. The product is often pure enough for use or can be purified via short-path silica chromatography (rapid elution to avoid decomposition).

Method B: Lithiation-Blocking Strategy (Traditional)

Direct lithiation of 3-methoxythiophene with

-BuLi occurs almost exclusively at C2 due to the Directed Ortho Metalation (DoM) effect of the methoxy group. To target C5, a blocking group strategy is required.

Protocol:

- Block C2: React 3-methoxythiophene with
-BuLi (-78°C) followed by TMSCl.
2-TMS-3-methoxythiophene.
- Functionalize C5: React the protected intermediate with

-BuLi (-78°C). Lithiation now occurs at C5 (the only remaining

-position).

- Borylation: Quench with (2-Isopropoxy-4,4,5,5-tetramethyl-1,3,2-dioxaborolane).
- Deprotection: Treat with TBAF or base to remove the TMS group.

Target Molecule.

Comparison of Methods

Feature	Method A: Ir-Catalyzed C-H Borylation	Method B: Lithiation-Blocking
Step Count	1 (Direct)	3-4 (Multi-step)
Atom Economy	High	Low (Requires TMS protection/deprotection)
Regioselectivity	Sterically controlled (>95:5 for C5)	Chemically controlled (DoM)
Scalability	Excellent (Process friendly)	Moderate (Cryogenic conditions required)
Cost	Higher (Iridium catalyst)	Lower (Lithium reagents)

Visualization: Synthesis Logic

The following diagram illustrates the divergent pathways to access the target isomer.

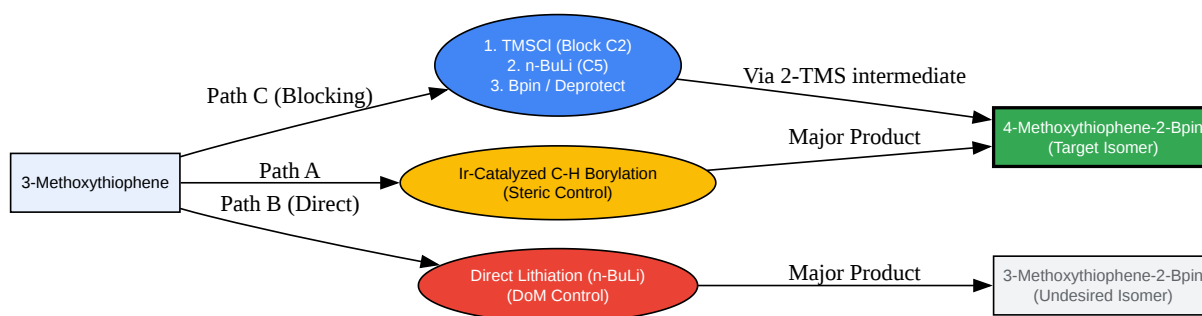

[Click to download full resolution via product page](#)

Figure 1: Synthesis pathways for 4-methoxythiophene-2-boronic acid pinacol ester showing the critical role of regiocontrol.

Reactivity & Applications

Suzuki-Miyaura Cross-Coupling

This boronate is an excellent nucleophile for Pd-catalyzed cross-coupling.

- Catalyst Choice:

or

are standard. For sterically demanding partners, use

/ XPhos.

- Base: Mild bases like

or

are preferred to minimize protodeboronation.

- Solvent: Dioxane/Water (4:1) or Toluene/Water systems.

Protodeboronation (Critical Stability Warning)

Electron-rich heteroaryl boronic acids are prone to protodeboronation (replacement of Bpin with H).

- Mechanism: Acid-catalyzed ipso-substitution.
- Risk Factor: High. The 4-methoxy group donates electron density, stabilizing the protonated intermediate at C2.
- Mitigation:
 - Store the pinacol ester (more stable than the free acid) at -20°C.
 - Avoid acidic workups.
 - Use anhydrous conditions if possible during coupling until the base is added.

Experimental Protocol: Suzuki Coupling Example

Objective: Coupling 4-methoxythiophene-2-Bpin with 4-bromoanisole.

- Setup: In a glovebox or under Ar flow, charge a reaction vial with:
 - 4-methoxythiophene-2-Bpin (1.2 equiv)
 - 4-bromoanisole (1.0 equiv)
 - (5 mol%)
 - (3.0 equiv)
- Solvent: Add degassed 1,4-Dioxane/Water (4:1, 0.2 M concentration).
- Reaction: Seal and heat to 80°C for 12 hours.
- Monitoring: Check via LC-MS. The disappearance of the bromide indicates completion.
- Workup: Dilute with EtOAc, wash with water/brine. Dry over

- Purification: Silica gel chromatography (Hexane/EtOAc gradient).

References

- Hartwig, J. F. (2012). Borylation and Silylation of C–H Bonds: A Platform for Diverse C–H Bond Functionalizations. *Chemical Reviews*, 110(2), 890–931. [Link](#)
- Miyaura, N., & Suzuki, A. (1995). Palladium-Catalyzed Cross-Coupling Reactions of Organoboron Compounds. *Chemical Reviews*, 95(7), 2457–2483. [Link](#)
- Snieckus, V. (1990). Directed Ortho Metalation. Tertiary Amide and O-Carbamate Directors in Synthetic Strategies for Polysubstituted Aromatics. *Chemical Reviews*, 90(6), 879–933. [Link](#)
- Lennox, A. J. J., & Lloyd-Jones, G. C. (2014). Selection of Boron Reagents for Suzuki–Miyaura Coupling. *Chemical Society Reviews*, 43, 412–443. [Link](#)
- To cite this document: BenchChem. [Comprehensive Guide: 4-Methoxythiophene-2-Boronic Acid Pinacol Ester]. BenchChem, [2026]. [Online PDF]. Available at: [\[https://www.benchchem.com/product/b2837203/docs#comprehensive-guide-4-methoxythiophene-2-boronic-acid-pinacol-ester\]](https://www.benchchem.com/product/b2837203/docs#comprehensive-guide-4-methoxythiophene-2-boronic-acid-pinacol-ester)

Disclaimer & Data Validity:

The information provided in this document is for Research Use Only (RUO) and is strictly not intended for diagnostic or therapeutic procedures. While BenchChem strives to provide accurate protocols, we make no warranties, express or implied, regarding the fitness of this product for every specific experimental setup.

Technical Support: The protocols provided are for reference purposes. Unsure if this reagent suits your experiment?

Need Industrial/Bulk Grade? [Request Custom Synthesis Quote](#)

BenchChem

Our mission is to be the trusted global source of essential and advanced chemicals, empowering scientists and researchers to drive progress in science and industry.

Contact

Address: 3281 E Guasti Rd

Ontario, CA 91761, United States

Phone: (601) 213-4426

Email: info@benchchem.com

[Contact our Ph.D. Support Team for a compatibility check](#)