

# Technical Guide: Stability and Reactivity of Chloromethyl Oxazoline Derivatives in Basic Media

**Author:** BenchChem Technical Support Team. **Date:** April 2026

## Compound of Interest

Compound Name:	2-(Chloromethyl)-4,5-dihydro-1,3-oxazole
CAS No.:	13627-32-2
Cat. No.:	B2833749

[Get Quote](#)

## Executive Summary

Chloromethyl oxazoline derivatives—specifically 2-(chloromethyl)-2-oxazoline and 4-(chloromethyl)-2-oxazoline—occupy a unique chemical space. Unlike their acid-sensitive counterparts which undergo rapid Cationic Ring-Opening Polymerization (CROP), these derivatives exhibit a dichotomy under basic conditions: the oxazoline ring itself is kinetically stable against hydrolysis, yet the chloromethyl moiety acts as a "trigger" for elimination or substitution.

This guide details the mechanistic pathways that dictate stability, providing protocols to control the divergence between dehydrochlorination (vinyl formation), nucleophilic substitution ( ), and ring preservation.

## Part 1: The Mechanistic Landscape

To manipulate these derivatives effectively, one must understand that "instability" in base is often a misnomer for "uncontrolled reactivity." The oxazoline ring is an imino ether; it is resistant to base-induced hydrolysis compared to esters or amides. The instability arises from the electrophilic chloromethyl group.

## The Three Divergent Pathways

When a chloromethyl oxazoline encounters a basic species (

), three outcomes compete based on the base's basicity vs. nucleophilicity (

vs.

) and steric profile.

- Pathway A: Dehydrochlorination (Elimination)
  - Mechanism:  
elimination. A base deprotonates the  
-carbon (or adjacent methylene), leading to the expulsion of chloride.
  - Outcome: Formation of 2-vinyl-2-oxazoline (from 2-chloromethyl) or exocyclic enol ethers.
  - Trigger: Strong, bulky bases (e.g.,  
-BuOK, DBU) in anhydrous media.
  - Relevance: This is the primary route for synthesizing polymerizable vinyl monomers.
- Pathway B: Nucleophilic Substitution (  
)
  - Mechanism: Direct attack of the nucleophile on the methylene carbon bearing the chlorine.
  - Outcome: A functionalized oxazoline ring (e.g., 2-(alkoxymethyl)-2-oxazoline).
  - Trigger: Non-bulky, strong nucleophiles (e.g.,

, Thiolates).

- Relevance: Used for attaching the oxazoline motif to other scaffolds (ligand synthesis).
- Pathway C: Ring Opening (Hydrolysis)
  - Mechanism: Nucleophilic attack at the carbon (C2) followed by ring cleavage.
  - Outcome:  
-(2-chloroacetyl)-amino alcohol.
  - Trigger: Aqueous strong bases (e.g.,  
,  
) at elevated temperatures (  
).
  - Relevance: Generally an degradation pathway to be avoided.

## Mechanistic Visualization

The following diagram maps the causality of these transformations.

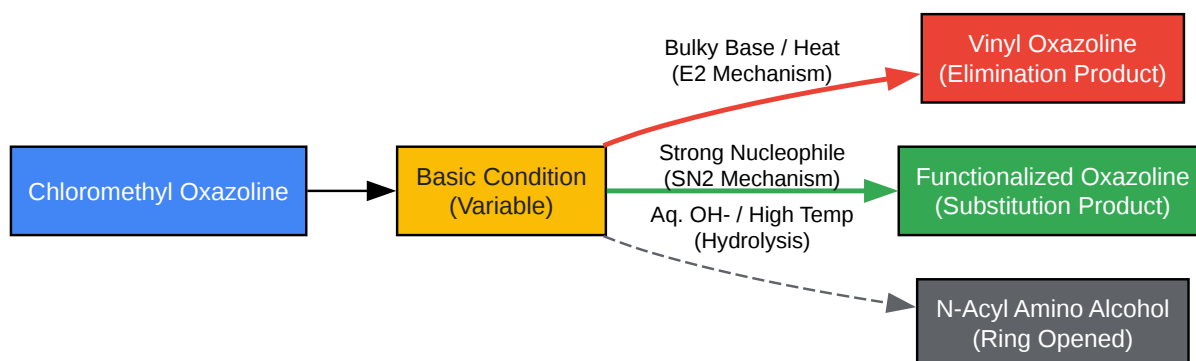

[Click to download full resolution via product page](#)

Caption: Divergent reactivity of chloromethyl oxazolines. Red path indicates elimination (vinyl formation); Green indicates substitution; Grey indicates degradation (hydrolysis).

## Part 2: Critical Parameters & Solvent Effects[1]

The stability of the chloromethyl derivative is heavily solvent-dependent.

Parameter	Condition	Effect on Stability/Reactivity
Solvent Polarity	Polar Aprotic (DMF, DMSO)	Accelerates Substitution ( ). Solvates cations, leaving naked anions to attack the chloromethyl group.
Solvent Polarity	Non-polar (Toluene, Hexane)	Favors Elimination. Promotes ion pairing; with bulky bases, this suppresses substitution.
Water Content	Anhydrous	High Stability. The ring resists opening indefinitely at RT.
Water Content	Aqueous ( )	Slow Degradation. Hydrolysis is slow at RT but accelerates >60°C.
Temperature		Kinetic Control. Suppresses elimination; allows for deprotonation without immediate chloride loss (if applicable).
Temperature		Thermodynamic Control. Promotes elimination to the conjugated vinyl system.

Expert Insight: To store chloromethyl oxazolines, maintain them in anhydrous, non-nucleophilic basic buffers (e.g., over solid

or with trace triethylamine) to scavenge any trace acid. Acid is the true enemy, as it triggers autocatalytic cationic polymerization.

## Part 3: Experimental Protocols

### Protocol: Self-Validating Stability Assay

Goal: Determine if a specific basic environment degrades the molecule or triggers elimination.

Reagents:

- Substrate: 2-chloromethyl-2-oxazoline (100 mg).
- Solvent:
  - DMSO (for polar stress test) or
  - (for non-polar).
- Internal Standard: 1,3,5-Trimethoxybenzene (10 mg) – Inert to base/acid.
- Base: 1.1 equiv of target base (e.g.,  
,  
,  
).

Workflow:

- Baseline Scan (  
  
): Dissolve substrate and internal standard. Acquire  
  
NMR. Integrate the  
  
singlet (  
  
ppm) against the standard.

- Induction: Add the base directly to the NMR tube (if soluble) or shake with aqueous base solution and separate layers.
- Monitoring: Acquire spectra at .
- Analysis Logic:
  - Loss of Ring: Disappearance of the triplet signals at and ppm (ring s).
  - Elimination: Appearance of vinyl protons ( ppm, dd).
  - Substitution: Shift of the peak upfield (e.g., to ppm for -alkyl).

## Protocol: Controlled Dehydrochlorination (Synthesis of Vinyl Oxazoline)

Goal: Selective elimination without ring opening.

Methodology:

- Setup: Flame-dried flask, atmosphere.
- Solvent: Dry THF (0.2 M concentration).

- Base Addition: Add (1.2 equiv) at . Why? Bulky base prevents attack at the chloromethyl carbon.
- Reaction: Stir at for 30 mins, then warm to RT for 2 hours.
- Quench: Filter off the resulting salt (do not use aqueous quench if possible to avoid hydrolysis during workup).
- Purification: Distillation under reduced pressure. Note: Vinyl oxazolines are prone to polymerization; add a radical inhibitor (e.g., BHT) immediately.

## Part 4: Analytical Strategy & Troubleshooting

### NMR Diagnostic Markers

When analyzing stability, look for these specific shifts (values approx. in

):

Moiety	Chemical Shift ( )	Diagnostic Change
Ring (O-CH <sub>2</sub> )	4.3 - 4.4 ppm (Triplet)	Disappears upon hydrolysis; shifts to ~3.6 ppm (alcohol).
Ring (N-CH <sub>2</sub> )	3.9 - 4.0 ppm (Triplet)	Disappears upon hydrolysis; shifts to ~3.4 ppm (amide).
Chloromethyl ( )	4.1 - 4.2 ppm (Singlet)	Vanishes upon elimination; replaced by vinyl signals.
Vinyl ( )	5.8 (dd), 6.2 (d) ppm	Appears only if base triggers elimination.

## Common Pitfalls

- The "Acid Spike" Error: Researchers often neutralize basic reaction mixtures with HCl. Do not do this. Excess acid will protonate the oxazoline nitrogen ( ), activating the ring for immediate hydrolysis or cationic polymerization.
  - Corrective Action: Neutralize with solid or weak buffers ( ).
- Thermal Degradation: Attempting to distill chloromethyl oxazolines at atmospheric pressure often leads to darkening/polymerization. Always use high vacuum ( mbar).

## Part 5: References

- Kobayashi, S., & Uyama, H. (2002). "Polymerization of cyclic imino ethers: From oxazolines to functional polymers." *Journal of Polymer Science Part A: Polymer Chemistry*. [Link](#)

- Frump, J. A. (1971). "Oxazolines.[1][2][3][4][5][6][7][8][9][10][11][12] Their preparation, reactions, and applications." [6][13] Chemical Reviews. [Link](#)
- Adams, N., & Schubert, U. S. (2007). "Poly(2-oxazolines) in biological and biomedical application contexts." Advanced Drug Delivery Reviews. [Link](#)
- Biedroń, T., & Kubisa, P. (2001). "Cationic polymerization of 2-vinyl-2-oxazoline." Macromolecular Chemistry and Physics. [Link](#)
- Gaucher, A., et al. (2005). "Oxazoline-based ligands in asymmetric catalysis." Tetrahedron: Asymmetry. [Link](#)

### Need Custom Synthesis?

BenchChem offers custom synthesis for rare earth carbides and specific isotopic labeling.

Email: [info@benchchem.com](mailto:info@benchchem.com) or [Request Quote Online](#).

## Sources

- 1. Investigation of cationic ring-opening polymerization of 2-oxazolines in the "green" solvent dihydrolevoglucosenone - PMC [pmc.ncbi.nlm.nih.gov]
- 2. Oxazoline - Wikipedia [en.wikipedia.org]
- 3. pubs.acs.org [pubs.acs.org]
- 4. A Facile Synthesis of 2-Oxazolines via Dehydrative Cyclization Promoted by Triflic Acid | MDPI [mdpi.com]
- 5. mdpi.com [mdpi.com]
- 6. warwick.ac.uk [warwick.ac.uk]
- 7. 2-Oxazoline synthesis [organic-chemistry.org]
- 8. A Facile Synthesis of 2-Oxazolines via Dehydrative Cyclization Promoted by Triflic Acid - PMC [pmc.ncbi.nlm.nih.gov]
- 9. researchgate.net [researchgate.net]
- 10. dspace.cuni.cz [dspace.cuni.cz]

- [11. Hydrolysis of hydrophobic poly\(2-oxazoline\)s and their subsequent modification via aza-Michael addition - PMC \[pmc.ncbi.nlm.nih.gov\]](#)
- [12. researchgate.net \[researchgate.net\]](#)
- [13. tu-dresden.de \[tu-dresden.de\]](#)
- To cite this document: BenchChem. [Technical Guide: Stability and Reactivity of Chloromethyl Oxazoline Derivatives in Basic Media]. BenchChem, [2026]. [Online PDF]. Available at: [<https://www.benchchem.com/product/b2833749/docs#technical-guide-stability-and-reactivity-of-chloromethyl-oxazoline-derivatives-in-basic-media>]

---

### Disclaimer & Data Validity:

The information provided in this document is for Research Use Only (RUO) and is strictly not intended for diagnostic or therapeutic procedures. While BenchChem strives to provide accurate protocols, we make no warranties, express or implied, regarding the fitness of this product for every specific experimental setup.

**Technical Support:** The protocols provided are for reference purposes. Unsure if this reagent suits your experiment?

**Need Industrial/Bulk Grade?** [Request Custom Synthesis Quote](#)

## BenchChem

Our mission is to be the trusted global source of essential and advanced chemicals, empowering scientists and researchers to drive progress in science and industry.

### Contact

Address: 3281 E Guasti Rd  
Ontario, CA 91761, United States  
Phone: (601) 213-4426  
Email: [info@benchchem.com](mailto:info@benchchem.com)

[Contact our Ph.D. Support Team for a compatibility check](#)

