

Application Note & Protocols: Strategic Preparation of Kinase Inhibitor Intermediates Using Glutaric Linkers

Author: BenchChem Technical Support Team. **Date:** April 2026

Compound of Interest

Compound Name: 4-[(6-Bromopyridin-2-yl)carbamoyl]butanoic acid
CAS No.: 1795517-39-3
Cat. No.: B2827135

[Get Quote](#)

Introduction: The Evolving Role of Linkers in Kinase Drug Discovery

The paradigm of kinase inhibition has evolved beyond simple competitive occupancy of the ATP-binding site. A significant advancement in the field is the development of bifunctional molecules, most notably Proteolysis Targeting Chimeras (PROTACs), which do not merely inhibit a target kinase but induce its complete degradation.[1] PROTACs are heterobifunctional molecules composed of a ligand for the target protein (the "warhead"), a ligand for an E3 ubiquitin ligase (the "anchor"), and a chemical linker connecting them.[1][2][3] This linker is not a passive spacer; its length, composition, and geometry are critical determinants of the PROTAC's ability to form a productive ternary complex (Kinase-PROTAC-E3 Ligase), which is the prerequisite for ubiquitination and subsequent proteasomal degradation of the kinase.[3][4][5]

Glutaric acid and its derivatives, particularly glutaric anhydride, have emerged as highly effective and versatile linkers in this context. The five-carbon chain of glutaric acid provides a favorable length and degree of flexibility to span the distance between the kinase and the E3 ligase, facilitating the necessary protein-protein interactions.[4] The strategic advantage of using glutaric anhydride lies in its ability to react efficiently with an amine-functionalized kinase inhibitor, yielding an intermediate that possesses a newly formed, stable amide bond and a terminal carboxylic acid. This carboxylic acid serves as a crucial chemical handle for subsequent conjugation to the E3 ligase ligand, making it a cornerstone of modular PROTAC synthesis.

This document provides a detailed guide for researchers, scientists, and drug development professionals on the synthesis, purification, and characterization of these pivotal kinase inhibitor-glutaric linker intermediates. We will delve into the underlying chemical principles, provide robust, step-by-step protocols, and discuss the rationale behind critical experimental choices.

Core Chemistry: The Glutaric Anhydride Ring-Opening Reaction

The foundational reaction for incorporating a glutaric linker is the nucleophilic acyl substitution between an amine-containing molecule and glutaric anhydride.[6] This reaction is efficient, high-yielding, and proceeds under mild conditions.

Mechanism: The reaction is initiated by the nucleophilic attack of the primary or secondary amine on one of the electrophilic carbonyl carbons of glutaric anhydride.[7][8] This attack leads to the opening of the six-membered anhydride ring, forming a tetrahedral intermediate which rapidly collapses to generate a stable amide bond and a terminal carboxylate. A subsequent proton transfer results in the final product: a molecule containing both an amide and a carboxylic acid functional group.

Why this chemistry is ideal:

- **Atom Economy:** The ring-opening is an addition reaction with high atom economy, generating no by-products from the core reaction.

- Orthogonality: The reaction creates a carboxylic acid handle that is unreactive under the initial reaction conditions, allowing for a clean, two-step construction of the final PROTAC.
- Predictability: The reaction is highly predictable and robust across a wide range of amine-containing substrates.

The overall synthetic strategy for building a PROTAC using this intermediate is visualized below.

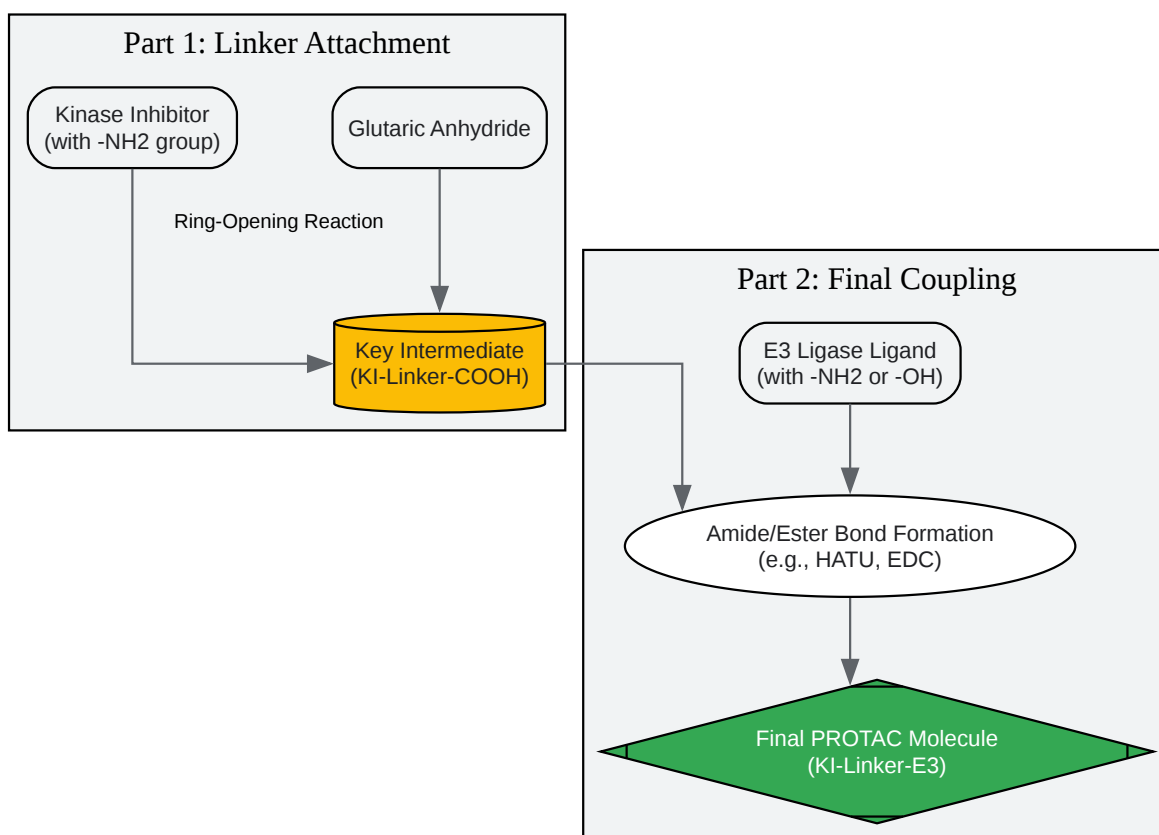

[Click to download full resolution via product page](#)

Caption: Overall workflow for PROTAC synthesis via a glutaric acid intermediate.

Experimental Protocols & Methodologies

Protocol 1: Synthesis of a Mono-Amide Glutaric Acid Intermediate

Principle: This protocol details the nucleophilic ring-opening of glutaric anhydride with an amine-functionalized kinase inhibitor fragment (KI-NH₂) to yield the desired intermediate (KI-NHCO-(CH₂)₃-COOH).

Materials:

- Amine-containing kinase inhibitor fragment (KI-NH₂, 1.0 equiv)
- Glutaric Anhydride (1.1 - 1.2 equiv)
- Anhydrous Dichloromethane (DCM) or N,N-Dimethylformamide (DMF)
- N,N-Diisopropylethylamine (DIPEA) or Triethylamine (TEA) (1.5 - 2.0 equiv)
- Argon or Nitrogen atmosphere
- Standard glassware (round-bottom flask, magnetic stirrer, etc.)

Step-by-Step Procedure:

- **Reaction Setup:** To a dry round-bottom flask under an inert atmosphere (Argon or Nitrogen), add the amine-containing kinase inhibitor fragment (1.0 equiv).
- **Dissolution:** Dissolve the fragment in a minimal amount of anhydrous DCM or DMF (approx. 0.1 M concentration).
- **Base Addition:** Add DIPEA or TEA (1.5 - 2.0 equiv) to the solution and stir for 5 minutes at room temperature.
 - **Scientist's Note:** While the reaction can proceed without a base, the addition of a non-nucleophilic base like DIPEA is highly recommended. It acts as a proton sponge, neutralizing any trace acidic impurities and ensuring the starting amine remains fully nucleophilic, often leading to faster and cleaner reactions.

- Anhydride Addition: Add glutaric anhydride (1.1 - 1.2 equiv) to the reaction mixture in a single portion.
- Reaction: Allow the reaction to stir at room temperature.
- Monitoring: Monitor the reaction progress periodically by Thin Layer Chromatography (TLC) or Liquid Chromatography-Mass Spectrometry (LC-MS). The reaction is complete upon full consumption of the starting amine (KI-NH₂). This typically takes 2-18 hours.
 - TLC System: A typical mobile phase would be 10% Methanol in DCM. The product should have a lower R_f value (be more polar) than the starting amine due to the newly introduced carboxylic acid.
 - LC-MS Analysis: Look for the disappearance of the starting material's mass peak and the appearance of a new peak corresponding to the mass of the product (Mass of KI-NH₂ + 114.1 g/mol).

Work-up and Isolation:

- Quenching: Once the reaction is complete, dilute the mixture with additional DCM or Ethyl Acetate.
- Aqueous Wash: Transfer the diluted mixture to a separatory funnel. Wash the organic layer sequentially with 0.5 M aqueous HCl (to remove the base), followed by water, and finally with brine.
 - Rationale: The acidic wash protonates the tertiary amine base (DIPEA/TEA), rendering it water-soluble for easy removal. The brine wash helps to remove residual water from the organic layer.
- Drying and Concentration: Dry the isolated organic layer over anhydrous sodium sulfate (Na₂SO₄) or magnesium sulfate (MgSO₄), filter, and concentrate the solvent under reduced pressure using a rotary evaporator to yield the crude product.

Protocol 2: Purification by Flash Column Chromatography

Principle: The crude product is purified based on its increased polarity compared to less polar impurities. The free carboxylic acid requires a specific mobile phase to ensure good separation.

Materials:

- Crude product from Protocol 1
- Silica Gel (230-400 mesh)
- Solvents: Dichloromethane (DCM), Methanol (MeOH), Acetic Acid (AcOH)
- Glass column and collection tubes

Step-by-Step Procedure:

- Column Packing: Prepare a silica gel column using a slurry packing method with a non-polar solvent like Hexane or DCM.
- Sample Loading: Dissolve the crude product in a minimal amount of DCM or the mobile phase. Alternatively, perform a "dry load" by adsorbing the crude product onto a small amount of silica gel, evaporating the solvent, and loading the resulting powder onto the top of the column.
- Elution: Begin elution with a mobile phase of 100% DCM. Gradually increase the polarity by adding Methanol. A typical gradient might be from 0% to 10% Methanol in DCM.
 - Critical Note: Add 0.5% - 1% acetic acid to the mobile phase. This is crucial to keep the product's carboxylic acid group fully protonated. An unprotonated carboxylate can interact strongly and variably with the silica, leading to significant peak tailing and poor separation.
- Fraction Collection: Collect fractions and analyze them by TLC.
- Product Isolation: Combine the fractions containing the pure product (as determined by TLC) and concentrate the solvent under reduced pressure to yield the purified glutaric amide-acid intermediate.

The entire synthesis and purification workflow is summarized in the diagram below.



[Click to download full resolution via product page](#)

Caption: Step-by-step workflow for synthesis and purification of the intermediate.

Product Characterization

Confirming the identity and purity of the synthesized intermediate is a critical self-validating step. The following data are expected for a successful synthesis.

Analytical Technique	Purpose	Expected Result for a Hypothetical Intermediate
LC-MS	Confirm Molecular Weight & Purity	Purity: >95% by UV chromatogram at 254 nm. Mass (ESI+): Calculated [M+H] ⁺ , Found [M+H] ⁺ ± 0.1 amu.
¹ H NMR (400 MHz, DMSO-d ₆)	Structural Confirmation	Amide Proton: Broad singlet, ~δ 8.0-8.5 ppm. Carboxylic Acid Proton: Very broad singlet, ~δ 12.0 ppm. Glutaric Protons: Multiplets between ~δ 1.8-2.3 ppm. Aromatic/aliphatic protons from the KI fragment should be present and may show slight shifts.
¹³ C NMR (100 MHz, DMSO-d ₆)	Carbon Skeleton Confirmation	Carboxylic Acid Carbonyl: ~δ 174 ppm. Amide Carbonyl: ~δ 172 ppm. Glutaric CH ₂ Carbons: Signals between ~δ 20-35 ppm.

Conclusion

The use of glutaric anhydride for linker attachment represents a robust, efficient, and highly modular strategy in the synthesis of kinase-targeting PROTACs and other complex inhibitors. The protocols outlined in this document provide a reliable foundation for producing the key amide-acid intermediates. The success of this synthesis relies on careful execution of the reaction, diligent monitoring, and appropriate purification techniques, particularly the use of an acidic modifier during chromatography. By understanding the causality behind each experimental step, researchers can confidently and reproducibly synthesize these critical building blocks for next-generation therapeutics.

References

- Stanoeva, E., & Co-workers. (2006). Study of the reaction between glutaric anhydride and N-benzylidenebenzylamine. Relevant transformations to new substituted piperidin-2-ones are discussed. Elsevier Ltd. [Link](#)
- Xiang, J., et al. (2017). Divergent synthesis of kinase inhibitor derivatives. PubMed. [Link](#)
- Rödinger, M., & Trauner, D. (2022). Controlling the Covalent Reactivity of a Kinase Inhibitor with Light. A discussion on the synthesis of inhibitors which may involve linker chemistry. NIH Public Access. [Link](#)
- Uslu, H. (2009). Experimental and Modeling Studies on the Extraction of Glutaric Acid by Trioctylamine. Journal of Chemical & Engineering Data. [Link](#)
- Tiwari, A., & Singh, S. (2021). Inhibitors, PROTACs and Molecular Glues as Diverse Therapeutic Modalities to Target Cyclin-Dependent Kinase. MDPI. [Link](#)
- Organic Syntheses. Glutaric acid preparation. Organic Syntheses Procedure. [Link](#)
- BenchChem. (2025). Application Notes and Protocols for Amide Bond Formation using EDC and HATU. BenchChem. [Link](#)
- Alena, K., et al. (2020). Novel approaches for the rational design of PROTAC linkers. Open Exploration Publishing. [Link](#)
- Reactory. Reactions of Acid Anhydrides. Reactory. [Link](#)
- MolecularCloud. (2025). The Cutting-Edge of Targeted Protein Degradation: PROTACs, Linkers, and Molecular Glues. MolecularCloud. [Link](#)
- LibreTexts. (2022). Chemistry of Amides. Chemistry LibreTexts. [Link](#)
- Google Patents. (1989). A process of preparing glutaric-anhydride-containing copolymers. Google Patents. [Link](#)
- Troup, R. I., et al. (2020). Current strategies for the design of PROTAC linkers: a critical review. PMC - NIH. [Link](#)

- Dong, J., et al. (2021). Targeting Protein Kinases Degradation by PROTACs. *Frontiers in Pharmacology*. [Link](#)
- LibreTexts. (2023). Acid Anhydrides React with Amines to Form Amides. *Chemistry LibreTexts*. [Link](#)
- Zhang, X., et al. (2025). Application of a macrocyclization strategy in kinase inhibitor development. *ScienceOpen*. [Link](#)
- Creative Proteomics. Glutaric Acid Analysis Service. *Creative Proteomics*. [Link](#)
- Xiang, J., et al. (2015). The discovery of kinase inhibitors by a combination of diversity-oriented synthesis and selective screening. *RSC Publishing*. [Link](#)
- Maccata, A., et al. (2023). A Sustainable Green Enzymatic Method for Amide Bond Formation. *MDPI*. [Link](#)
- Google Patents. (2014). Preparation method of glutaric acid. *Google Patents*. [Link](#)
- Uslu, H. (2015). A Study on Glutaric Acid Extraction by Tridodecylamine: Equilibria and Models. *ResearchGate*. [Link](#)
- Piazz, F. D., & Inesi, C. (2021). Amide bond formation strategies: latest advances on a dateless transformation. *AIR Unimi*. [Link](#)
- Valeur, E., & Bradley, M. (2008). Amide bond formation: beyond the myth of coupling reagents. *Luxembourg Bio Technologies*. [Link](#)
- Zhang, X., et al. (2025). Application of a macrocyclization strategy in kinase inhibitor development. *ResearchGate*. [Link](#)
- ScholarWorks. (2025). Anhydride and Amine Reactions to Make Diverse Amide and Carboxylic Acid Containing Compounds. *ScholarWorks*. [Link](#)

Need Custom Synthesis?

BenchChem offers custom synthesis for rare earth carbides and specific isotopic labeling.

Email: info@benchchem.com or [Request Quote Online](#).

Sources

- [1. Frontiers | Targeting Protein Kinases Degradation by PROTACs \[frontiersin.org\]](#)
- [2. mdpi.com \[mdpi.com\]](#)
- [3. Current strategies for the design of PROTAC linkers: a critical review - PMC \[pmc.ncbi.nlm.nih.gov\]](#)
- [4. Novel approaches for the rational design of PROTAC linkers \[explorationpub.com\]](#)
- [5. The Cutting-Edge of Targeted Protein Degradation: PROTACs, Linkers, and Molecular Glues | MolecularCloud \[molecularcloud.org\]](#)
- [6. Anhydride and Amine Reactions to Make Diverse Amide and Carboxylic Acid Containing Compounds | ScholarWorks \[scholarworks.calstate.edu\]](#)
- [7. Reactions of Acid Anhydrides | Reactory \[reactory.app\]](#)
- [8. chem.libretexts.org \[chem.libretexts.org\]](#)
- To cite this document: BenchChem. [Application Note & Protocols: Strategic Preparation of Kinase Inhibitor Intermediates Using Glutaric Linkers]. BenchChem, [2026]. [Online PDF]. Available at: [<https://www.benchchem.com/product/b2827135/docs#application-note-protocols-strategic-preparation-of-kinase-inhibitor-intermediates-using-glutaric-linkers>]

Disclaimer & Data Validity:

The information provided in this document is for Research Use Only (RUO) and is strictly not intended for diagnostic or therapeutic procedures. While BenchChem strives to provide accurate protocols, we make no warranties, express or implied, regarding the fitness of this product for every specific experimental setup.

Technical Support: The protocols provided are for reference purposes. Unsure if this reagent suits your experiment?

Need Industrial/Bulk Grade? [Request Custom Synthesis Quote](#)

BenchChem

Our mission is to be the trusted global source of essential and advanced chemicals, empowering scientists and researchers to drive progress in science and industry.

Contact

Address: 3281 E Guasti Rd

Ontario, CA 91761, United States

Phone: (601) 213-4426

Email: info@benchchem.com

[Contact our Ph.D. Support Team for a compatibility check](#)