

# Technical Support Center: Navigating the Synthesis of Strained Cyclobutane Rings

**Author:** BenchChem Technical Support Team. **Date:** April 2026

## Compound of Interest

**Compound Name:** Ethyl 3-hydroxycyclobutanecarboxylate

**CAS No.:** 1408074-72-5; 160351-97-3

**Cat. No.:** B2824136

[Get Quote](#)

Welcome to the Technical Support Center for the synthesis of strained cyclobutane rings. This guide is designed for researchers, scientists, and professionals in drug development who are navigating the synthetic challenges associated with these valuable four-membered carbocycles. The inherent ring strain of cyclobutanes, while a source of their unique reactivity and utility, also presents significant hurdles in their synthesis.<sup>[1]</sup> This resource provides in-depth troubleshooting guidance and frequently asked questions (FAQs) to address common issues encountered in the laboratory.

## Troubleshooting Guide: A Problem-Solving Approach

This section is structured to provide direct answers and actionable solutions to specific problems you may be encountering during your experiments.

### Issue 1: Low or No Yield in [2+2] Photocycloaddition Reactions

Question: My [2+2] photocycloaddition reaction is giving me a low yield or no product at all. What are the likely causes and how can I troubleshoot this?

Answer:

Low yields in [2+2] photocycloadditions are a common challenge. The issue often lies in one or more of the following areas: the photochemical setup, reaction conditions, or substrate reactivity. A systematic approach to troubleshooting is recommended.

Causality and Recommended Actions:

- Inadequate Light Source or Wavelength: The photochemical reaction is initiated by the absorption of light by one of the alkene partners. If the light source is not appropriate, the reaction will not proceed efficiently.
  - Troubleshooting:
    - Verify Wavelength: Ensure the emission wavelength of your lamp overlaps with the absorption spectrum of your substrate. For many enones, a medium-pressure mercury lamp is effective. For more selective reactions, LEDs with specific wavelengths (e.g., 370 nm UVA or 440 nm blue LEDs) can be advantageous.<sup>[2]</sup>
    - Check Lamp Intensity and Age: The intensity of UV lamps can decrease over time. If you are using an older lamp, its output may be insufficient.
    - Reaction Vessel Material: Use quartz reaction vessels for reactions requiring lower UV wavelengths, as borosilicate (Pyrex) glass will filter out a significant portion of the UV light.<sup>[2]</sup>
- Presence of Quenchers: Molecular oxygen is a notorious quencher of triplet excited states, which are often key intermediates in these reactions.
  - Troubleshooting:
    - Degas Your Solvent: Thoroughly degas the solvent and reaction mixture before and during irradiation. Common methods include bubbling a stream of argon or nitrogen

through the solution for 15-30 minutes or using freeze-pump-thaw cycles for more sensitive reactions.[3]

- Sub-optimal Concentration: Reaction kinetics can be highly dependent on the concentration of your reactants.
  - Troubleshooting:
    - Dilute vs. Concentrated: If intermolecular cycloaddition is desired, overly dilute conditions can disfavor the reaction. Conversely, for intramolecular reactions, high concentrations might lead to intermolecular side products. Experiment with a range of concentrations to find the optimal balance.
- Low Substrate Reactivity or Inefficient Intersystem Crossing: Some substrates do not efficiently form the necessary excited state upon direct irradiation.
  - Troubleshooting:
    - Employ a Photosensitizer: For substrates that are poor light absorbers or have low quantum yields for intersystem crossing, a triplet sensitizer can be used. The sensitizer absorbs the light and then transfers the energy to one of the reactants. Common sensitizers include acetone, benzophenone, and thioxanthone.[4] The choice of sensitizer should be based on its triplet energy relative to the substrate.

## Issue 2: Poor Diastereoselectivity in Cyclobutane Formation

Question: I am obtaining my desired cyclobutane product, but as a mixture of diastereomers with poor selectivity. How can I improve the diastereoselectivity?

Answer:

Achieving high diastereoselectivity is a critical challenge in cyclobutane synthesis, as the stereochemistry of the final product can significantly impact its biological activity. The stereochemical outcome is influenced by a complex interplay of steric and electronic factors in the transition state.

### Causality and Recommended Actions:

- Solvent Effects: The polarity of the solvent can influence the stability of intermediates and transition states, thereby affecting the diastereoselectivity.
  - Troubleshooting:
    - Solvent Screening: Experiment with a range of solvents with varying polarities, from non-polar (e.g., hexanes, toluene) to polar aprotic (e.g., acetonitrile, dichloromethane) and polar protic solvents. In some cases, a change in solvent can even lead to a reversal of diastereoselectivity.
- Reaction Temperature: Lowering the reaction temperature often enhances selectivity by increasing the energy difference between the diastereomeric transition states.
  - Troubleshooting:
    - Low-Temperature Reactions: Conduct the reaction at lower temperatures. This is particularly effective in many thermal and metal-catalyzed cycloadditions. For photochemical reactions, this can be achieved using a cooling system for the reaction vessel.
- Steric Hindrance: The steric bulk of substituents on the reacting partners can play a significant role in directing the stereochemical outcome.
  - Troubleshooting:
    - Substrate Modification: If possible, consider modifying your substrates to include bulkier groups that can favor the formation of one diastereomer over the other.
- Catalyst and Ligand Choice in Metal-Catalyzed Reactions: In metal-catalyzed [2+2] cycloadditions, the choice of the metal and its coordinating ligands is paramount in controlling stereoselectivity.
  - Troubleshooting:

- **Ligand Screening:** For enantioselective processes, a screen of chiral ligands is often necessary to find the optimal match for your specific substrates.

### Issue 3: Product Decomposition or Ring-Opening

Question: I am isolating my cyclobutane product, but it appears to be unstable and decomposes upon workup or purification. What is causing this, and how can I prevent it?

Answer:

The inherent ring strain of cyclobutanes (approximately 26 kcal/mol) makes them susceptible to ring-opening reactions under certain conditions.<sup>[5][6][7]</sup> This instability can be exacerbated by the presence of certain functional groups.

Causality and Recommended Actions:

- **Harsh Workup Conditions:** The use of strong acids or bases during the workup can promote ring-opening.
  - **Troubleshooting:**
    - **Mild Workup:** Employ mild workup procedures. Use saturated aqueous sodium bicarbonate or ammonium chloride for quenching instead of strong acids or bases. Minimize exposure to acidic or basic conditions.
- **Thermal Instability during Purification:** High temperatures during purification methods like distillation can lead to decomposition.
  - **Troubleshooting:**
    - **Avoid High Temperatures:** Use purification techniques that do not require high temperatures. Flash column chromatography on silica gel at room temperature is often a suitable method. If distillation is necessary, perform it under reduced pressure to lower the boiling point.
- **Photochemical Degradation:** Some cyclobutane products may be photolabile and can decompose upon exposure to light.

- Troubleshooting:
  - Protect from Light: After the reaction is complete, protect your product from light by wrapping the flask in aluminum foil or using amber-colored glassware.

## Frequently Asked Questions (FAQs)

Q1: What are the main synthetic strategies for constructing cyclobutane rings?

A1: The most common method is the [2+2] cycloaddition reaction, which can be promoted by light (photocycloaddition), heat (thermal cycloaddition), or transition metal catalysts.<sup>[8]</sup> Other important methods include the ring expansion of cyclopropanes and various intramolecular cyclization reactions.<sup>[9][10]</sup>

Q2: How does ring strain affect the reactivity of cyclobutanes?

A2: The significant ring strain in cyclobutanes makes them more reactive than their acyclic or larger-ring counterparts.<sup>[1]</sup> This strain can be released in reactions such as ring-opening, ring-expansion, and rearrangements, making cyclobutanes versatile synthetic intermediates.<sup>[8][11]</sup>

Q3: Are there any safety concerns specific to the synthesis of strained cyclobutanes?

A3: Yes, due to their high strain energy, some highly substituted or functionalized cyclobutanes can be thermally unstable and potentially energetic. It is crucial to handle these compounds with care, avoid excessive heating, and use appropriate personal protective equipment. When conducting photochemical reactions, always use proper shielding to protect yourself from UV radiation.

Q4: How can I characterize my cyclobutane product to confirm its structure and stereochemistry?

A4: A combination of spectroscopic techniques is typically used.

- Nuclear Magnetic Resonance (NMR) Spectroscopy: <sup>1</sup>H and <sup>13</sup>C NMR are essential for determining the connectivity and relative stereochemistry of the substituents on the cyclobutane ring. Coupling constants (J-values) in <sup>1</sup>H NMR can provide valuable information about the dihedral angles between protons, which helps in assigning stereochemistry.

- Mass Spectrometry (MS): To confirm the molecular weight of the product.
- Infrared (IR) Spectroscopy: To identify the functional groups present in the molecule.
- X-ray Crystallography: For an unambiguous determination of the three-dimensional structure and absolute stereochemistry, especially for crystalline products.

## Experimental Protocols

### Protocol 1: General Procedure for a Photochemical [2+2] Cycloaddition

This protocol provides a general guideline for a typical photochemical [2+2] cycloaddition reaction.

Materials:

- Alkene 1 (1.0 equivalent)
- Alkene 2 (1.0-2.0 equivalents)
- Degassed solvent (e.g., acetone, acetonitrile, or dichloromethane)
- Quartz or borosilicate (Pyrex) reaction vessel
- Photochemical reactor with a suitable lamp (e.g., medium-pressure mercury lamp or LED)
- Magnetic stirrer
- Cooling system (optional)

Procedure:

- In the reaction vessel, dissolve Alkene 1 and Alkene 2 in the degassed solvent. The concentration will need to be optimized for your specific reaction.
- Seal the vessel and continue to degas the solution by bubbling with an inert gas (argon or nitrogen) for 15-30 minutes.

- Place the reaction vessel in the photochemical reactor and begin irradiation with the chosen light source. If necessary, use a cooling system to maintain the desired reaction temperature.
- Monitor the progress of the reaction by TLC, GC-MS, or  $^1\text{H}$  NMR.
- Once the reaction is complete, turn off the light source and remove the reaction vessel.
- Concentrate the reaction mixture under reduced pressure.
- Purify the crude product by flash column chromatography on silica gel to obtain the desired cyclobutane.

## Data Presentation

Reaction Type	Reactants	Conditions	Yield (%)	Diastereoselectivity
Photocycloaddition	Enone + Alkene	hv, Acetone	50-90	Varies
Metal-Catalyzed	Diene + Alkyne	[Rh(I)] catalyst, 60 °C	70-95	High
Thermal Cycloaddition	Ketene + Alkene	Heat	60-80	Generally high

Note: Yields and selectivities are highly substrate-dependent and the values in the table are representative examples.

## Visualizations

### Troubleshooting Workflow for Low Yield in [2+2] Photocycloaddition

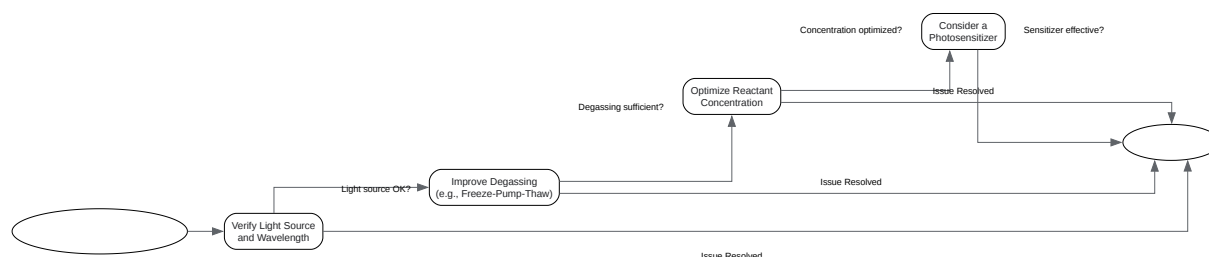

[Click to download full resolution via product page](#)

Caption: A decision-making workflow for troubleshooting low yields in photochemical [2+2] cycloaddition reactions.

## General Mechanism of a Photosensitized [2+2] Cycloaddition

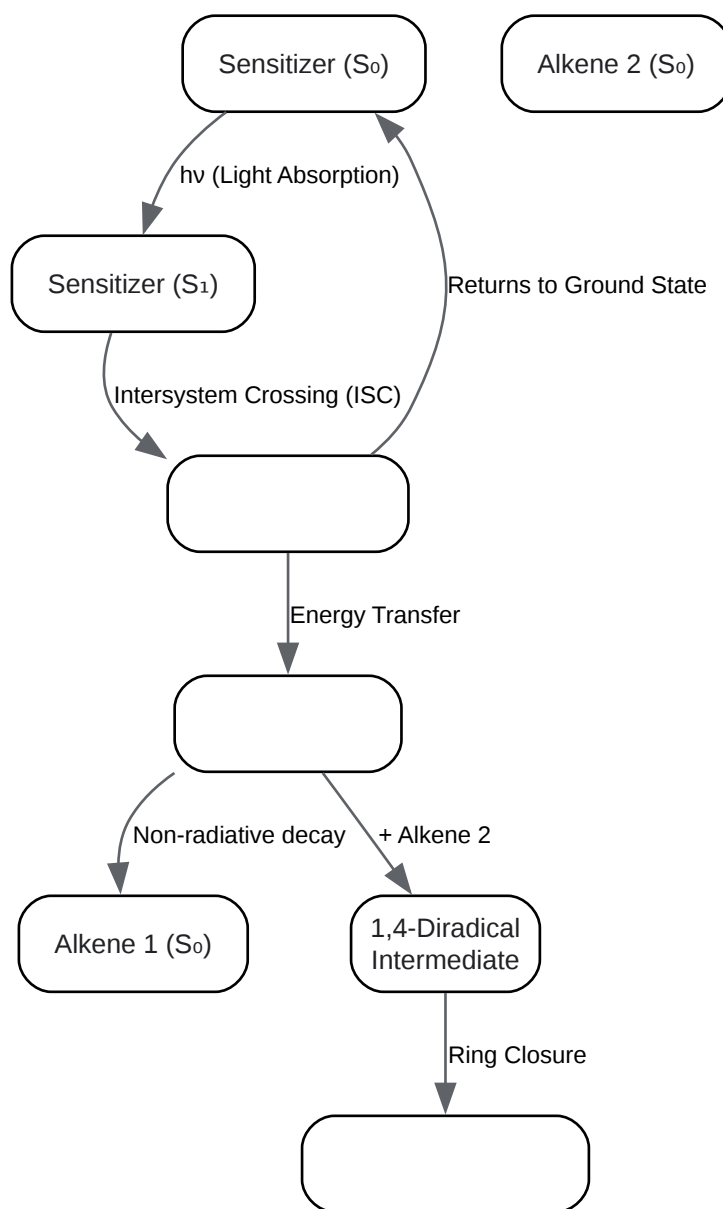

[Click to download full resolution via product page](#)

Caption: The catalytic cycle of a photosensitized [2+2] cycloaddition reaction, proceeding through a triplet excited state.

## References

- Diva-Portal.org. (2021). Tandem Ring Opening/Intramolecular [2 + 2] Cycloaddition Reaction for the Synthesis of Cyclobutane Fused Thiazolino-2-Pyridones. [[Link](#)]

- Radboud Repository. (2024). Library Synthesis of Cyclobutanol Derivatives by Hyperbaric [2+2] Cycloaddition Reactions. [[Link](#)]
- ACS Publications. (2025). Synthesis of gem-Diarylcyclobutanes via Palladium-Catalyzed Ring Expansion of Arylidencyclopropanes with Anilines. [[Link](#)]
- PMC. (n.d.). Intramolecular thermal stepwise [2 + 2] cycloadditions: investigation of a stereoselective synthesis of [n.2.0]-bicyclic lactones. [[Link](#)]
- ETH Research Collection. (2020). Ring-fused cyclobutanes via cycloisomerization of alkylidencyclopropane acylsilanes. [[Link](#)]
- RSC Publishing. (2024). Synthesis of cyclobutane-fused chromanones via gold-mediated photocatalysis. [[Link](#)]
- Docslib. (n.d.). Chemistry-of-Cyclopropane-and-Cyclobutane.docx. [[Link](#)]
- Organic Chemistry Portal. (n.d.). Cyclobutane synthesis. [[Link](#)]
- ACS Publications. (2025). A Simple [2 + 2] Photocycloaddition Reaction that Proceeds in an NMR Tube Illuminated by Daylight. [[Link](#)]
- University of Bristol. (n.d.). Photochemical Reactors. [[Link](#)]
- Shilpa Enterprises. (n.d.). MANUAL FOR PHOTOCHEMICAL REACTOR SETUP. [[Link](#)]
- HepatoChem. (n.d.). Photochemical Reactor Setup | Photoreactor Design by HepatoChem. [[Link](#)]
- Scribd. (n.d.). Experimental Set Up For Photochemical Reactions. [[Link](#)]
- PMC. (n.d.). Photoredox-Catalyzed Cyclobutane Synthesis by a Deboronative Radical Addition–Polar Cyclization Cascade. [[Link](#)]
- ResearchGate. (n.d.). (PDF) Recent advances in the application of [2 + 2] cycloaddition in the chemical synthesis of cyclobutane-containing natural products. [[Link](#)]

- RSC Publishing. (n.d.). Isolation of elusive cyclobutane ligands via a template-assisted photochemical [2 + 2] cycloaddition reaction and their utility in engineering crystalline solids. [\[Link\]](#)
- Chemistry LibreTexts. (2023). 1.2: Cycloaddition Reactions. [\[Link\]](#)
- Semantic Scholar. (n.d.). Cyclobutane and cyclobutene synthesis: catalytic enantioselective [2+2] cycloadditions. [\[Link\]](#)
- University of Bristol Research Portal. (2021). [2+2]-Photocycloaddition Reactions in the Synthesis of Novel Scaffolds and Natural Products. [\[Link\]](#)
- Master Organic Chemistry. (2014). Cycloalkanes - Ring Strain In Cyclopropane And Cyclobutane. [\[Link\]](#)
- YouTube. (2014). Photochemical (2+2) Cycloaddition Example. [\[Link\]](#)
- PMC. (2016). Strain Release Amination. [\[Link\]](#)
- SciSpace. (n.d.). Synthesis of cyclobutane lignans via an organic single electron oxidant–electron relay system. [\[Link\]](#)
- Cengage. (n.d.). 4.3 Stability of Cycloalkanes: Ring Strain – Organic Chemistry: A Tenth Edition. [\[Link\]](#)
- AIR Unimi. (n.d.). Ultra-Strained Non-aromatic Rings. [\[Link\]](#)
- PMC. (n.d.). Enzymatic Construction of Highly Strained Carbocycles. [\[Link\]](#)
- Chemistry LibreTexts. (2024). 4.3: Stability of Cycloalkanes - Ring Strain. [\[Link\]](#)
- Cengage. (n.d.). 2.10 Stability of Cycloalkanes: Ring Strain – Fundamentals of Organic Chemistry. [\[Link\]](#)
- RSC Blogs. (2018). Harnessing ring strain to drive the classically forbidden thermal [2+2] addition of cycloalkenes. [\[Link\]](#)
- YouTube. (2015). Stability of cycloalkanes | Organic chemistry | Khan Academy. [\[Link\]](#)

**Need Custom Synthesis?**

BenchChem offers custom synthesis for rare earth carbides and specific isotopic labeling.

Email: [info@benchchem.com](mailto:info@benchchem.com) or [Request Quote Online](#).

## Sources

- [1. masterorganicchemistry.com](https://www.masterorganicchemistry.com) [[masterorganicchemistry.com](https://www.masterorganicchemistry.com)]
- [2. pdf.benchchem.com](https://pdf.benchchem.com) [[pdf.benchchem.com](https://pdf.benchchem.com)]
- [3. pdf.benchchem.com](https://pdf.benchchem.com) [[pdf.benchchem.com](https://pdf.benchchem.com)]
- [4. benchchem.com](https://www.benchchem.com) [[benchchem.com](https://www.benchchem.com)]
- [5. Enzymatic Construction of Highly Strained Carbocycles - PMC](https://pubmed.ncbi.nlm.nih.gov/311111111/) [[pmc.ncbi.nlm.nih.gov](https://pubmed.ncbi.nlm.nih.gov/311111111/)]
- [6. chem.libretexts.org](https://chem.libretexts.org) [[chem.libretexts.org](https://chem.libretexts.org)]
- [7. 2.10 Stability of Cycloalkanes: Ring Strain – Fundamentals of Organic Chemistry](#) [[ncstate.pressbooks.pub](https://ncstate.pressbooks.pub)]
- [8. pdf.benchchem.com](https://pdf.benchchem.com) [[pdf.benchchem.com](https://pdf.benchchem.com)]
- [9. pubs.acs.org](https://pubs.acs.org) [[pubs.acs.org](https://pubs.acs.org)]
- [10. Intramolecular thermal stepwise \[2 + 2\] cycloadditions: investigation of a stereoselective synthesis of \[n.2.0\]-bicyclic lactones - PMC](https://pubmed.ncbi.nlm.nih.gov/311111111/) [[pmc.ncbi.nlm.nih.gov](https://pubmed.ncbi.nlm.nih.gov/311111111/)]
- [11. diva-portal.org](https://diva-portal.org) [[diva-portal.org](https://diva-portal.org)]
- To cite this document: BenchChem. [Technical Support Center: Navigating the Synthesis of Strained Cyclobutane Rings]. BenchChem, [2026]. [Online PDF]. Available at: [<https://www.benchchem.com/product/b2824136/docs#technical-support-center-navigating-the-synthesis-of-strained-cyclobutane-rings>]

---

### Disclaimer & Data Validity:

The information provided in this document is for Research Use Only (RUO) and is strictly not intended for diagnostic or therapeutic procedures. While BenchChem strives to provide accurate protocols, we make no warranties, express or implied, regarding the fitness of this product for every specific experimental setup.

**Technical Support:** The protocols provided are for reference purposes. Unsure if this reagent suits your experiment?

**Need Industrial/Bulk Grade?** [Request Custom Synthesis Quote](#)

## BenchChem

Our mission is to be the trusted global source of essential and advanced chemicals, empowering scientists and researchers to drive progress in science and industry.

### Contact

Address: 3281 E Guasti Rd  
Ontario, CA 91761, United States  
Phone: (601) 213-4426  
Email: [info@benchchem.com](mailto:info@benchchem.com)

[Contact our Ph.D. Support Team for a compatibility check](#)