

Comparative Reaction Rates of Substituted Benzenesulfonic Acids

Author: BenchChem Technical Support Team. **Date:** May 2026

Compound of Interest

Compound Name: 4-Nitrobenzenesulfonic Acid Hydrate
CAS No.: 1089293-70-8; 138-42-1
Cat. No.: B2820915

[Get Quote](#)

A Guide to Stability, Reactivity, and Substituent Effects

Executive Summary For researchers in drug discovery and process chemistry, benzenesulfonic acids present a chemical paradox. The electronic factors that enhance the synthetic utility of their derivatives (e.g., sulfonyl chlorides forming sulfonamides) are often the exact factors that compromise the hydrolytic stability of the parent acid.

This guide objectively compares these rates using the Hammett Linear Free Energy Relationship (LFER) framework, providing experimental protocols to validate stability profiles in early-stage development.

Theoretical Framework: The Hammett Control

The reactivity of meta- and para-substituted benzenesulfonic acids is governed by the electronic nature of the substituent (

). This is quantified by the Hammett equation:

- (Substituent Constant): Measures the electron-donating or withdrawing power of
.[\[1\]](#)[\[2\]](#)[\[3\]](#)
 - Negative

(e.g.,

-OMe,

) : Electron Donating Group (EDG).
 - Positive

(e.g.,

-NO

,

) : Electron Withdrawing Group (EWG).[\[2\]](#)
- (Reaction Constant): Measures the sensitivity of the reaction to these electronic effects.[\[1\]](#)[\[2\]](#)
[\[4\]](#)

The Divergence of Reactivity

The critical insight for this guide is that Desulfonation and Aminolysis have opposite values.

Reaction Type	Mechanism	Sign	Effect of EDG ((-OMe)	Effect of EWG ((-NO ₂)
Desulfonation	Electrophilic Aromatic Subst. (Reverse)	Negative ()	Accelerates (Unstable)	Retards (Stable)
Aminolysis	Nucleophilic Acyl-like Substitution	Positive ()	Retards (Low Yields)	Accelerates (High Yields)

Comparative Analysis 1: Hydrolytic Stability (Desulfonation)

Desulfonation is the reverse of sulfonation. It occurs in acidic aqueous media at elevated temperatures.^[5] This is a critical stability parameter for sulfonic acid intermediates during scale-up.

Mechanism

The reaction proceeds via a Wheland intermediate (sigma complex). The rate-determining step is the protonation of the ring carbon bearing the sulfonate group.

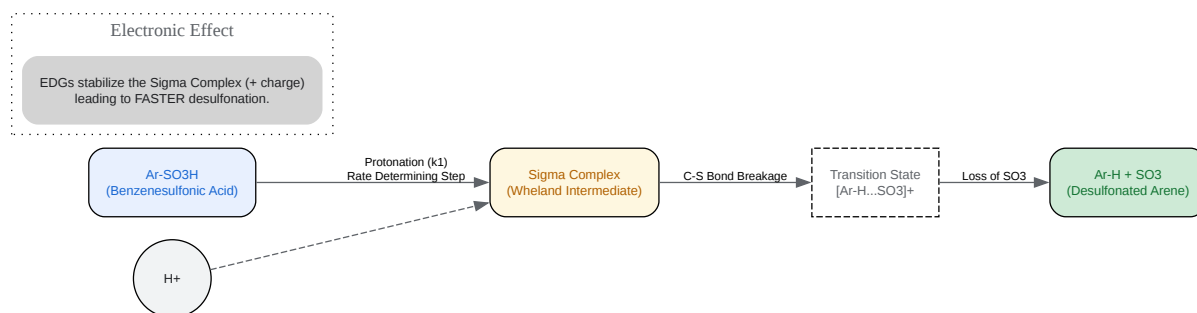

[Click to download full resolution via product page](#)

Figure 1: Mechanism of acid-catalyzed desulfonation. The protonation of the ipso-carbon is the rate-limiting step.

Comparative Rate Data (Desulfonation)

Condition: 70-90% H

SO

, 140°C. Trend: Electron-rich rings lose the sulfonate group rapidly. Electron-poor rings are highly stable.

Substituent ()	Value	Relative Rate ()	Stability Assessment
-Methoxy (-OMe)	-0.27	~150	Highly Unstable (Hydrolyzes easily)
-Methyl (-Me)	-0.17	~25	Unstable
Hydrogen (-H)	0.00	1.0	Baseline
-Chloro (-Cl)	+0.23	~0.1	Stable
-Nitro (-NO)	+0.78	< 0.001	Highly Stable

Note: Relative rates are approximate approximations derived from standard Hammett plots for electrophilic aromatic substitution where

. [1, 2]

Comparative Analysis 2: Synthetic Reactivity (Aminolysis)

For drug development, benzenesulfonic acids are often converted to sulfonyl chlorides () and reacted with amines to form sulfonamides.

Mechanism

This is a nucleophilic attack on the sulfur atom. Unlike desulfonation, electron withdrawal facilitates the attack by making the sulfur more electrophilic.

Comparative Rate Data (Aminolysis)

Condition: Reaction of

with aniline in methanol, 25°C. Trend: Electron-poor rings react faster.

Substituent ()	Value	Relative Rate ()	Synthetic Implication
-Nitro (-NO)	+0.78	~85	Rapid Reaction (Mild conditions required)
-Chloro (-Cl)	+0.23	~4.5	Fast
Hydrogen (-H)	0.00	1.0	Baseline
-Methyl (-Me)	-0.17	~0.6	Slow (May require heating)
-Methoxy (-OMe)	-0.27	~0.3	Sluggish (Requires forcing conditions)

Note: Data derived from Hammett plots with

for nucleophilic attack on sulfonyl sulfur. [3, 4]

Experimental Protocol: Measuring Desulfonation Kinetics

To validate the stability of a new sulfonic acid derivative, use this UV-Vis kinetic protocol. This method relies on the spectral difference between the sulfonic acid and the desulfonated arene.

Reagents & Equipment[6][7]

- Solvent: 50% (w/w) H

SO

(aq).

- Substrate: 1.0 mM solution of the substituted benzenesulfonic acid.
- Instrument: UV-Vis Spectrophotometer with temperature-controlled cell holder.

Workflow Diagram

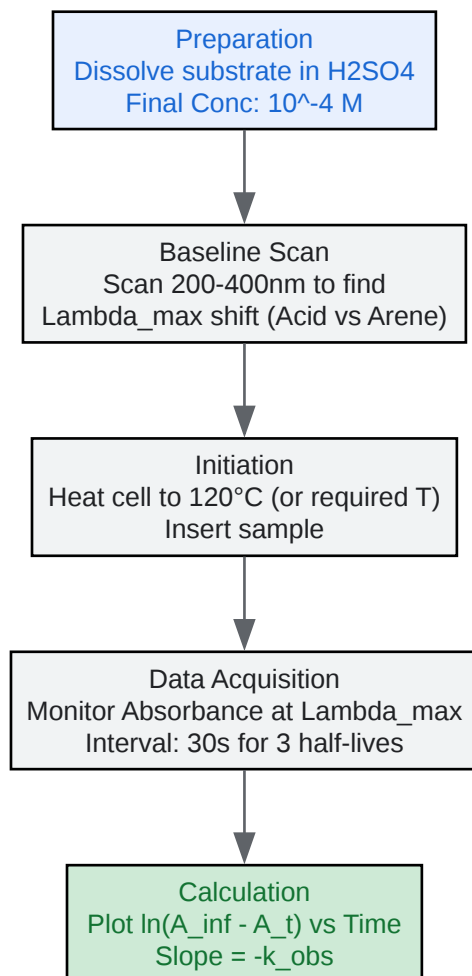

[Click to download full resolution via product page](#)

Figure 2: Kinetic workflow for determining hydrolytic stability.

Step-by-Step Methodology

- Spectral Characterization: First, synthesize or purchase the expected desulfonated product (the arene). Record UV spectra of both the sulfonic acid and the arene in the acid medium to identify the wavelength of maximum difference ().
- Sample Preparation: Prepare a stock solution of the sulfonic acid in the sulfuric acid medium. Ensure the concentration follows Beer-Lambert law linearity (typically

to

M).

- Kinetic Run:
 - Pre-heat the UV cell holder to the target temperature (e.g., 120°C for stable acids, 80°C for unstable ones).
 - Introduce the sample and seal the cuvette (Teflon stopper) to prevent evaporation.
 - Monitor absorbance at

continuously.
- Data Analysis:
 - The reaction is Pseudo-First Order (Acid is in large excess).
 - Calculate

using the integrated rate law:
 - Plot

vs. time. The slope is

.

References

- Cerfontain, H. (1968). Mechanistic Aspects in Aromatic Sulfonation and Desulfonation. Interscience Publishers.[3]
- Wanders, A. C. M., & Cerfontain, H. (1967).[6] Kinetics of the desulfonation of benzenesulfonic acid and the toluenesulfonic acids in aqueous sulfuric acid. Recueil des Travaux Chimiques des Pays-Bas, 86(11), 1199-1216.[6]
- Rogne, O. (1970). The hydrolysis of substituted benzenesulphonyl chlorides in water. Journal of the Chemical Society B: Physical Organic, 1294-1296.

- Hansch, C., Leo, A., & Taft, R. W. (1991). A survey of Hammett substituent constants and resonance and field parameters. *Chemical Reviews*, 91(2), 165-195.

Need Custom Synthesis?

BenchChem offers custom synthesis for rare earth carbides and specific isotopic labeling.

Email: info@benchchem.com or [Request Quote Online](#).

Sources

- [1. scribd.com \[scribd.com\]](https://www.scribd.com)
- [2. Unit 4: Free Energy Relationships \[research.cm.utexas.edu\]](https://research.cm.utexas.edu)
- [3. web.viu.ca \[web.viu.ca\]](https://web.viu.ca)
- [4. Hammett equation - Wikipedia \[en.wikipedia.org\]](https://en.wikipedia.org)
- [5. researchgate.net \[researchgate.net\]](https://www.researchgate.net)
- [6. masterorganicchemistry.com \[masterorganicchemistry.com\]](https://www.masterorganicchemistry.com)
- To cite this document: BenchChem. [Comparative Reaction Rates of Substituted Benzenesulfonic Acids]. BenchChem, [2026]. [Online PDF]. Available at: [\[https://www.benchchem.com/product/b2820915/docs#comparative-reaction-rates-of-substituted-benzenesulfonic-acids\]](https://www.benchchem.com/product/b2820915/docs#comparative-reaction-rates-of-substituted-benzenesulfonic-acids)

Disclaimer & Data Validity:

The information provided in this document is for Research Use Only (RUO) and is strictly not intended for diagnostic or therapeutic procedures. While BenchChem strives to provide accurate protocols, we make no warranties, express or implied, regarding the fitness of this product for every specific experimental setup.

Technical Support: The protocols provided are for reference purposes. Unsure if this reagent suits your experiment?

Need Industrial/Bulk Grade? [Request Custom Synthesis Quote](#)

BenchChem

Our mission is to be the trusted global source of essential and advanced chemicals, empowering scientists and researchers to drive progress in science and industry.

Contact

Address: 3281 E Guasti Rd

Ontario, CA 91761, United States

Phone: (601) 213-4426

Email: info@benchchem.com

[Contact our Ph.D. Support Team for a compatibility check](#)