

The Intersection of *cis*-VZ185 and the SWI/SNF Complex: A Technical Guide

Author: BenchChem Technical Support Team. **Date:** April 2026

Compound of Interest

Compound Name: *cis*-VZ185

Cat. No.: B2814098

[Get Quote](#)

For Researchers, Scientists, and Drug Development Professionals

Abstract

The SWI/SNF (SWItch/Sucrose Non-Fermentable) chromatin remodeling complex is a critical regulator of gene expression, and its subunits are frequently mutated in a variety of human cancers, making it a compelling target for therapeutic development.^{[1][2][3][4]} This technical guide delves into the relationship between the SWI/SNF complex and *cis*-VZ185, a chemical probe that serves as a crucial negative control for its active counterpart, VZ185. VZ185 is a potent and selective PROTAC (Proteolysis Targeting Chimera) degrader of the bromodomain-containing proteins BRD7 and BRD9, which are integral subunits of the SWI/SNF complexes.^{[5][6][7][8]} Understanding the nuanced interactions—or lack thereof—between *cis*-VZ185 and the SWI/SNF complex is paramount for the accurate interpretation of experimental data aimed at elucidating the therapeutic potential of targeting these epigenetic regulators. This document provides a comprehensive overview of the core concepts, quantitative data, experimental methodologies, and visual representations of the associated molecular pathways and experimental workflows.

The SWI/SNF Chromatin Remodeling Complex

The mammalian SWI/SNF complex is a multi-subunit machinery that utilizes the energy from ATP hydrolysis to modulate the structure of chromatin, thereby influencing gene expression, DNA replication, and repair.[2][5][9] There are three main types of SWI/SNF complexes in mammals: the canonical BAF (cBAF), polybromo-associated BAF (PBAF), and non-canonical BAF (ncBAF/GBAF) complexes.[1][2] These complexes share core subunits but are defined by the presence of unique components, including a mutually exclusive ATPase subunit, either SMARCA4 (BRG1) or SMARCA2 (BRM).[1][2][3][4]

BRD9 is a subunit of the BAF complex, while its close homolog BRD7 is a component of the PBAF complex.[6][7][8] The bromodomains of BRD7 and BRD9 are responsible for recognizing and binding to acetylated lysine residues on histone tails, a key mechanism for tethering the SWI/SNF complex to specific genomic loci. Given that approximately 20% of human cancers harbor mutations in SWI/SNF subunit genes, the targeted degradation of these subunits presents a promising therapeutic strategy.[2][3]

VZ185 and the Role of the Inactive Epimer, *cis*-VZ185

VZ185 is a bifunctional molecule, a PROTAC, designed to specifically target BRD7 and BRD9 for degradation.[8][10] It achieves this by simultaneously binding to the bromodomains of BRD7/9 and the von Hippel-Lindau (VHL) E3 ubiquitin ligase.[5][6][7] This induced proximity facilitates the ubiquitination of BRD7 and BRD9, marking them for degradation by the proteasome.

***cis*-VZ185** is the (S)-hydroxy diastereoisomer of VZ185.[6][7] While it retains comparable binding affinity to the bromodomains of BRD7 and BRD9, it is unable to effectively recruit the VHL E3 ligase.[6][7] This critical difference renders ***cis*-VZ185** incapable of inducing the degradation of BRD7 and BRD9.[5][6][7] Consequently, ***cis*-VZ185** serves as an ideal negative control in experiments designed to study the effects of VZ185-mediated degradation of BRD7 and BRD9. Any observed biological effect with VZ185, but not with ***cis*-VZ185**, can be more confidently attributed to the degradation of the target proteins rather than off-target effects of the chemical scaffold.

Quantitative Data

The following tables summarize the key quantitative data for VZ185, highlighting its potency and selectivity. Data for **cis-VZ185** is primarily qualitative, confirming its inability to induce degradation.

Table 1: Degradation Potency of VZ185

Cell Line	Target Protein	DC50 (nM)	Dmax (%)	Assay Method	Reference
RI-1	BRD9	1.8	>95	Western Blot (8h)	[7]
RI-1	BRD7	4.5	>95	Western Blot (8h)	[7]
HEK293	HiBiT-BRD9	4.0	-	Live-cell degradation	[7]
HEK293	HiBiT-BRD7	34.5	-	Live-cell degradation	[7]
EOL-1	BRD9	2.3	-	WES assay (18h)	[8]
A-204	BRD9	8.3	-	WES assay (18h)	[8]
EOL-1	-	2-8	-	Degradation analysis	[10][11]
A-204	-	2-8	-	Degradation analysis	[10][11]

Table 2: Cellular Viability (Cytotoxicity) of VZ185

Cell Line	EC50 (nM)	Assay Method	Reference
EOL-1	3.4	CellTiter-Glo	[8]
A-204	39.8	CellTiter-Glo	[8]
EOL-1	3	-	[11]
A-402	40	-	[11]

Table 3: Binding Affinities and Thermodynamic Properties of VZ185

Parameter	Value	Method	Reference
VHL Binary KD	26 ± 9 nM	ITC	[7]
VHL Ternary KD (with BRD9-BD)	27 ± 3 nM	ITC	[7]
BRD9-BD Binary KD	5.1 ± 0.6 nM	ITC	[7]
VHL Binary KD	35 ± 5 nM	FP	[7]
VHL Ternary KD (with BRD9-BD)	35 ± 6 nM	FP	[7]
Ternary Complex Total Stability (ΔG)	-21.7 kcal/mol	ITC	[6][7]
Cooperativity (α)	1.0	ITC/FP	[8]

Experimental Protocols

Western Blot Analysis for Protein Degradation

This protocol is adapted from methodologies described in studies of VZ185.[5][9]

- Cell Culture and Treatment: Plate cells (e.g., RI-1, HeLa) at an appropriate density and allow them to adhere overnight. Treat the cells with various concentrations of VZ185 or **cis-VZ185** (e.g., 1 nM to 10 μ M) and a DMSO control for specified time points (e.g., 2, 4, 8, 24 hours).

- **Cell Lysis:** After treatment, wash the cells with ice-cold PBS and lyse them in RIPA buffer supplemented with protease and phosphatase inhibitors.
- **Protein Quantification:** Determine the protein concentration of each lysate using a BCA protein assay.
- **SDS-PAGE and Western Blotting:** Normalize protein amounts for each sample, add Laemmli buffer, and denature by heating. Separate the proteins by SDS-PAGE and transfer them to a PVDF membrane.
- **Immunoblotting:** Block the membrane with 5% non-fat milk or BSA in TBST for 1 hour at room temperature. Incubate the membrane with primary antibodies against BRD7, BRD9, and a loading control (e.g., β -actin, Vinculin) overnight at 4°C. Wash the membrane with TBST and incubate with HRP-conjugated secondary antibodies for 1 hour at room temperature.
- **Detection and Analysis:** Visualize the protein bands using an enhanced chemiluminescence (ECL) detection system. Quantify the band intensities using densitometry software. Normalize the target protein levels to the loading control and express them as a percentage relative to the DMSO-treated control.

Mass Spectrometry for Proteome-wide Selectivity

This protocol is based on the description of proteomic experiments with VZ185.[\[6\]](#)[\[9\]](#)

- **Cell Treatment and Lysis:** Treat cells (e.g., RI-1) in triplicate with DMSO, 100 nM VZ185, or 100 nM **cis-VZ185** for a defined period (e.g., 4 hours). Harvest and lyse the cells.
- **Protein Digestion and TMT Labeling:** Reduce, alkylate, and digest the proteins with trypsin. Label the resulting peptides with tandem mass tags (TMT) for multiplexed quantitative analysis.
- **Liquid Chromatography-Mass Spectrometry (LC-MS/MS):** Combine the labeled peptide samples and analyze them by LC-MS/MS.
- **Data Analysis:** Process the raw data using a suitable software suite to identify and quantify proteins. Perform statistical analysis to identify proteins with significant changes in

abundance in the VZ185-treated samples compared to the DMSO and **cis-VZ185**-treated controls.

Live-Cell Kinetic Degradation Assay (HiBiT Assay)

This protocol is based on the use of CRISPR/Cas9-mediated endogenous tagging.^{[5][7]}

- **Cell Line Generation:** Use CRISPR/Cas9 to endogenously tag the target proteins (e.g., BRD7, BRD9) with a HiBiT tag in a suitable cell line (e.g., HEK293).
- **Assay Setup:** Plate the engineered cells in a white-bottom 96-well plate. Add the LgBiT protein and a luciferin substrate to the cells.
- **Compound Treatment and Luminescence Reading:** Add serial dilutions of VZ185 or **cis-VZ185** to the wells. Measure the luminescence signal at regular intervals over a time course (e.g., 24 hours) using a plate reader.
- **Data Analysis:** The luminescence signal is proportional to the amount of HiBiT-tagged protein. Normalize the data to the DMSO control at each time point to determine the percentage of protein degradation. Calculate DC50 values from the dose-response curves.

Visualizations

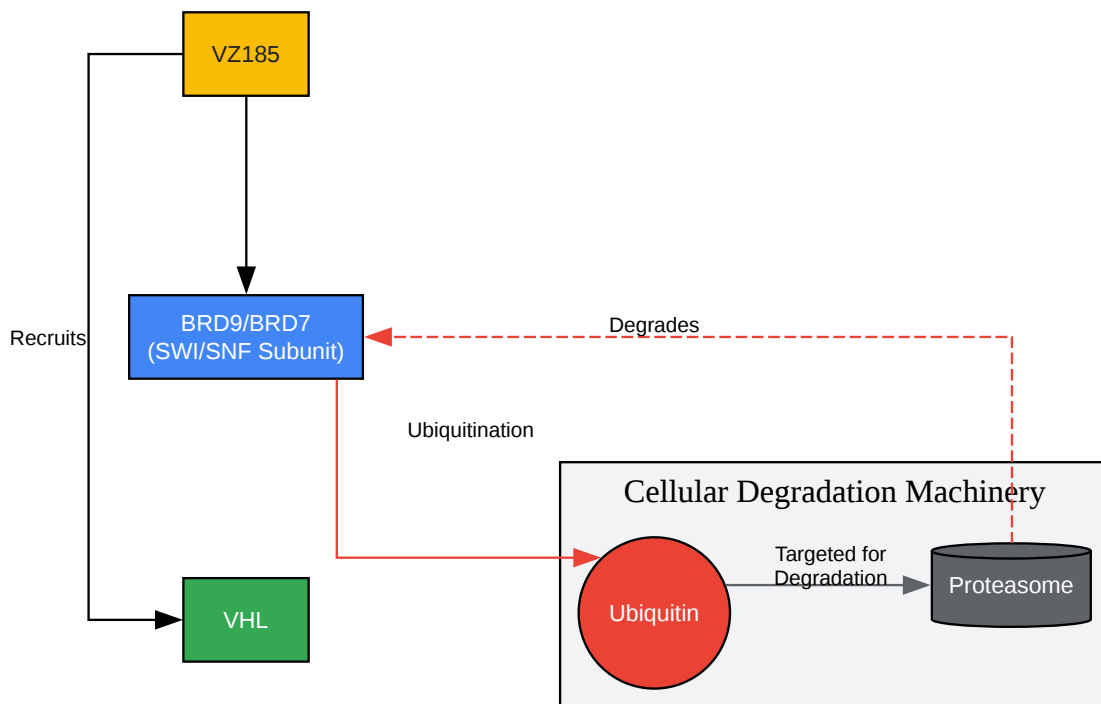

[Click to download full resolution via product page](#)

Caption: Mechanism of action of VZ185 leading to the degradation of BRD7/BRD9.

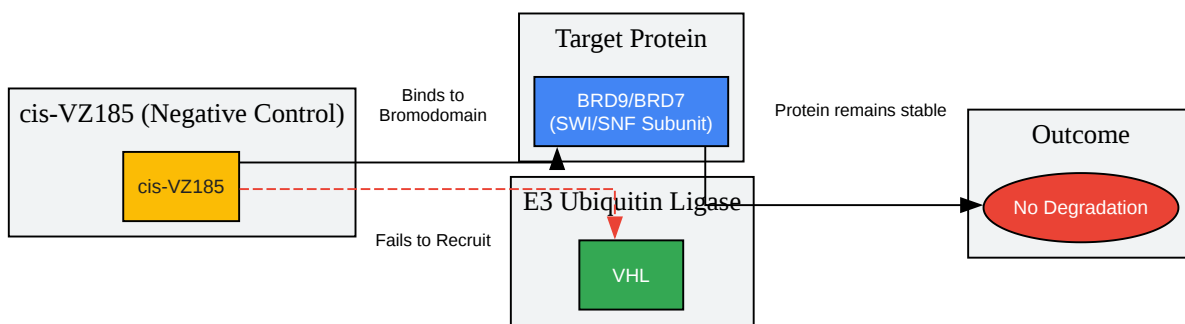

[Click to download full resolution via product page](#)

Caption: The inactive nature of **cis-VZ185**, which binds to BRD7/BRD9 but fails to recruit VHL.

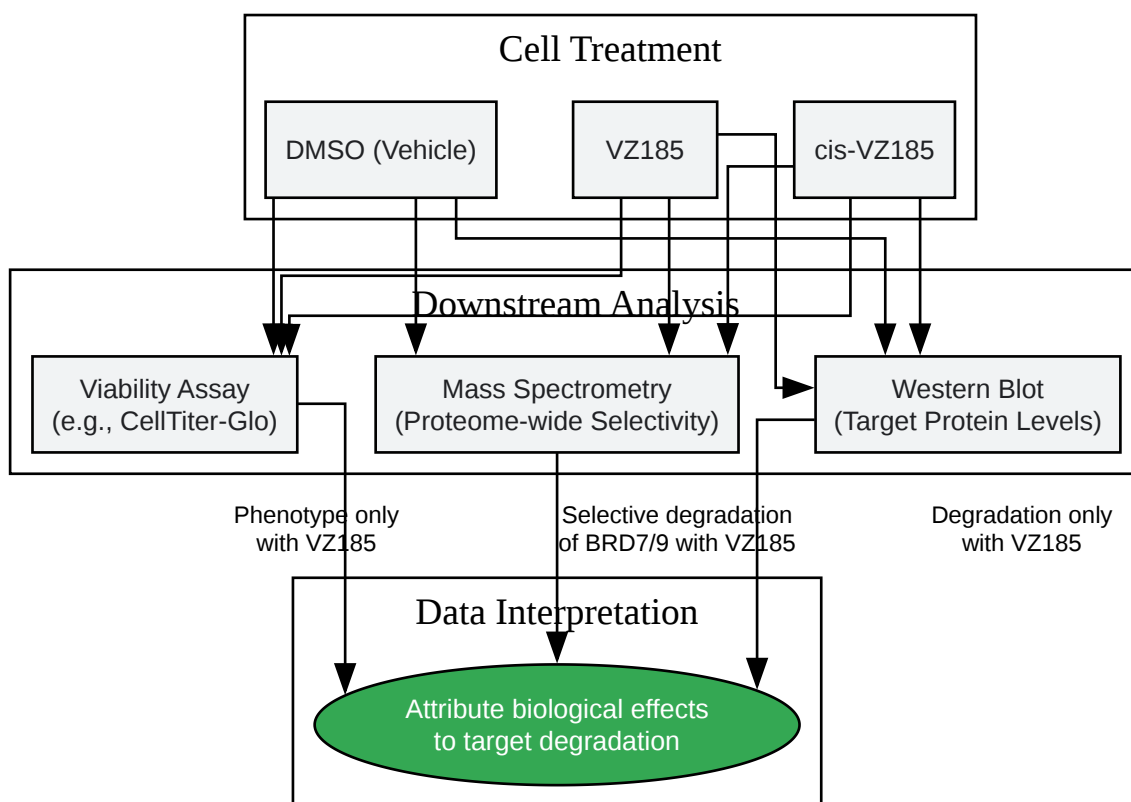

[Click to download full resolution via product page](#)

Caption: A logical workflow for experiments utilizing VZ185 and its negative control, **cis-VZ185**.

Need Custom Synthesis?

BenchChem offers custom synthesis for rare earth carbides and specific isotopic labeling.

Email: info@benchchem.com or [Request Quote Online](#).

References

- 1. The SWI/SNF Complex: A Frequently Mutated Chromatin Remodeling Complex in Cancer - PubMed [pubmed.ncbi.nlm.nih.gov]
- 2. mdpi.com [mdpi.com]
- 3. jitc.bmj.com [jitc.bmj.com]
- 4. aacrjournals.org [aacrjournals.org]

- [5. pubs.acs.org \[pubs.acs.org\]](https://pubs.acs.org)
- [6. opnme.com \[opnme.com\]](https://opnme.com)
- [7. Pardon Our Interruption \[opnme.com\]](https://opnme.com)
- [8. Pardon Our Interruption \[opnme.com\]](https://opnme.com)
- [9. Iterative Design and Optimization of Initially Inactive Proteolysis Targeting Chimeras \(PROTACs\) Identify VZ185 as a Potent, Fast, and Selective von Hippel–Lindau \(VHL\) Based Dual Degradation Probe of BRD9 and BRD7 - PMC \[pmc.ncbi.nlm.nih.gov\]](https://pubs.acs.org)
- [10. medchemexpress.com \[medchemexpress.com\]](https://medchemexpress.com)
- [11. medchemexpress.com \[medchemexpress.com\]](https://medchemexpress.com)
- To cite this document: BenchChem. [The Intersection of cis-VZ185 and the SWI/SNF Complex: A Technical Guide]. BenchChem, [2026]. [Online PDF]. Available at: [\[https://www.benchchem.com/product/b2814098/docs#the-intersection-of-cis-vz185-and-the-swi-snf-complex-a-technical-guide\]](https://www.benchchem.com/product/b2814098/docs#the-intersection-of-cis-vz185-and-the-swi-snf-complex-a-technical-guide)

Disclaimer & Data Validity:

The information provided in this document is for Research Use Only (RUO) and is strictly not intended for diagnostic or therapeutic procedures. While BenchChem strives to provide accurate protocols, we make no warranties, express or implied, regarding the fitness of this product for every specific experimental setup.

Technical Support: The protocols provided are for reference purposes. Unsure if this reagent suits your experiment?

Need Industrial/Bulk Grade? [Request Custom Synthesis Quote](#)

BenchChem

Our mission is to be the trusted global source of essential and advanced chemicals, empowering scientists and researchers to drive progress in science and industry.

Contact

Address: 3281 E Guasti Rd
Ontario, CA 91761, United States
Phone: (601) 213-4426
Email: info@benchchem.com

Contact our Ph.D. Support Team for a compatibility check