

# Reproducibility of cis-J-113863: A Comparative Guide

**Author:** BenchChem Technical Support Team. **Date:** May 2026

## Compound of Interest

Compound Name: *cis-J-113863*

CAS No.: 202796-42-7

Cat. No.: B2807753

[Get Quote](#)

For Researchers, Scientists, and Drug Development Professionals

This guide provides a comparative analysis of the reported efficacy of **cis-J-113863**, a potent chemokine receptor 1 (CCR1) antagonist. While direct inter-laboratory reproducibility studies are not publicly available, this document synthesizes data from various independent sources to offer an objective overview of its pharmacological profile. The consistency of key performance indicators across different suppliers and research publications suggests a reliable and reproducible activity profile for this compound.

## Quantitative Data Summary

The half-maximal inhibitory concentration (IC<sub>50</sub>) is a critical measure of a drug's potency. The following tables summarize the reported IC<sub>50</sub> values for **cis-J-113863** against its primary targets, human and mouse CCR1, as well as its activity at the closely related CCR3. The data presented here is collated from prominent life science product suppliers and research articles, demonstrating a high degree of consistency in the reported values.

Table 1: Potency of **cis-J-113863** at CCR1

Target Receptor	Reported IC50 (nM)	Source(s)
Human CCR1	0.9	[1][2][3]
Mouse CCR1	5.8	[1][2][3]

Table 2: Potency of **cis-J-113863** at CCR3

Target Receptor	Reported IC50 (nM)	Source(s)
Human CCR3	0.58	[2][3]
Mouse CCR3	460	[2][3]

Table 3: Activity of **cis-J-113863** at Other Chemokine Receptors

A study by Gbaguidi et al. investigated the interaction of **cis-J-113863** with CCR2 and CCR5, revealing binding and functional effects in the micromolar range.[4]

Target Receptor	Reported IC50 ( $\mu$ M) for binding of $^{125}$ I-CCL2/CCL4	Source
CCR2	~10	[4]
CCR5	~10	[4]

## Experimental Protocols

While detailed, step-by-step protocols for the original IC50 determinations are proprietary, this section outlines general methodologies for key experiments involving **cis-J-113863** based on publicly available information.

### In Vitro Radioligand Binding Assays

These assays are fundamental for determining the binding affinity of a compound to its receptor.

Objective: To determine the concentration of **cis-J-113863** required to displace a radiolabeled ligand from the CCR1 receptor, thereby calculating the IC50 value.

General Methodology:

- Cell Culture: Use a stable cell line expressing high levels of the target receptor (e.g., human CCR1).
- Membrane Preparation: Prepare cell membrane fractions that contain the receptor of interest.
- Binding Reaction: Incubate the cell membranes with a known concentration of a radiolabeled CCR1 ligand (e.g., [125I]-MIP-1 $\alpha$ ) and varying concentrations of **cis-J-113863**.
- Separation: Separate the bound from the free radioligand, typically by rapid filtration through a glass fiber filter.
- Detection: Quantify the amount of radioactivity retained on the filter using a scintillation counter.
- Data Analysis: Plot the percentage of inhibition of radioligand binding against the concentration of **cis-J-113863**. The IC50 value is the concentration of the compound that inhibits 50% of the specific binding of the radioligand.

## Chemotaxis Assays

These functional assays measure the ability of a compound to inhibit cell migration induced by a chemokine.

Objective: To assess the functional antagonist activity of **cis-J-113863** by measuring its ability to block CCR1-mediated cell migration.

General Methodology:

- Cell Preparation: Use a cell line or primary cells that express CCR1 and are known to migrate in response to CCR1 ligands (e.g., eosinophils or transfected cell lines).

- **Assay Setup:** Use a chemotaxis chamber (e.g., a Boyden chamber) with a porous membrane separating an upper and a lower well.
- **Loading:** Place the cells in the upper well and the CCR1 ligand (e.g., MIP-1 $\alpha$ ) in the lower well. Add varying concentrations of **cis-J-113863** to the upper well with the cells.
- **Incubation:** Incubate the chamber for a sufficient time to allow for cell migration.
- **Quantification:** Count the number of cells that have migrated to the lower well.
- **Data Analysis:** Plot the percentage of inhibition of cell migration against the concentration of **cis-J-113863** to determine the IC50 value.

## In Vivo Administration for Animal Models

**Objective:** To evaluate the efficacy of **cis-J-113863** in a disease model, such as experimental autoimmune encephalomyelitis (EAE), a model for multiple sclerosis.

**General Methodology** (based on a study in a mouse model of MS):[\[5\]](#)[\[6\]](#)

- **Compound Preparation:** Prepare a stock solution of **cis-J-113863**. A general protocol suggests dissolving the compound in a vehicle such as DMSO, followed by dilution in a suitable buffer for injection.[\[3\]](#)
- **Animal Model:** Induce EAE in a susceptible mouse strain (e.g., SJL/J mice).
- **Administration:** Administer **cis-J-113863** at a specific dose (e.g., 10 mg/kg) via a defined route (e.g., intraperitoneal injection) on a set schedule.
- **Outcome Measures:** Monitor clinical scores, inflammatory markers, and other relevant pathological readouts to assess the effect of the treatment.

## Visualizations

### CCR1 Signaling Pathway

The following diagram illustrates the general signaling pathway of the C-C chemokine receptor 1 (CCR1), the primary target of **cis-J-113863**. Upon binding of its cognate ligands (e.g., CCL3/MIP-1 $\alpha$ , CCL5/RANTES), CCR1, a G protein-coupled receptor (GPCR), activates

intracellular signaling cascades that lead to cellular responses such as chemotaxis, inflammation, and cell activation. **cis-J-113863** acts as an antagonist, blocking the binding of these ligands and thereby inhibiting these downstream effects.

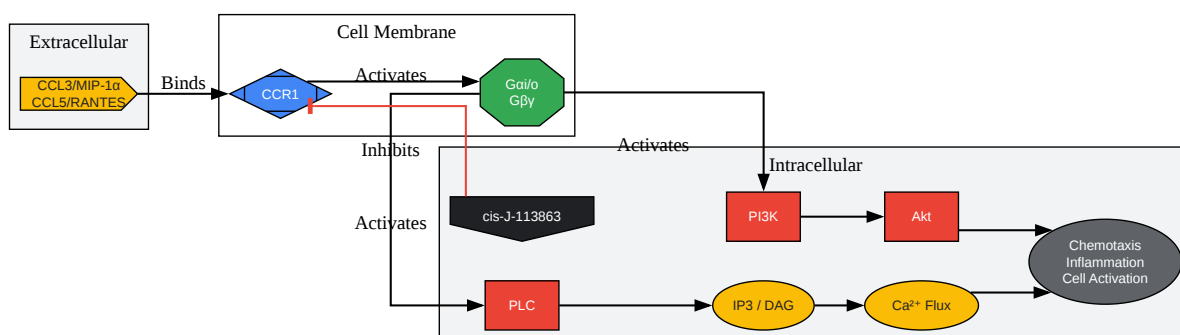

[Click to download full resolution via product page](#)

Caption: CCR1 signaling pathway and the inhibitory action of **cis-J-113863**.

## Experimental Workflow for In Vitro Antagonist Assay

This diagram outlines a typical workflow for determining the in vitro antagonist activity of a compound like **cis-J-113863** using a cell-based assay.

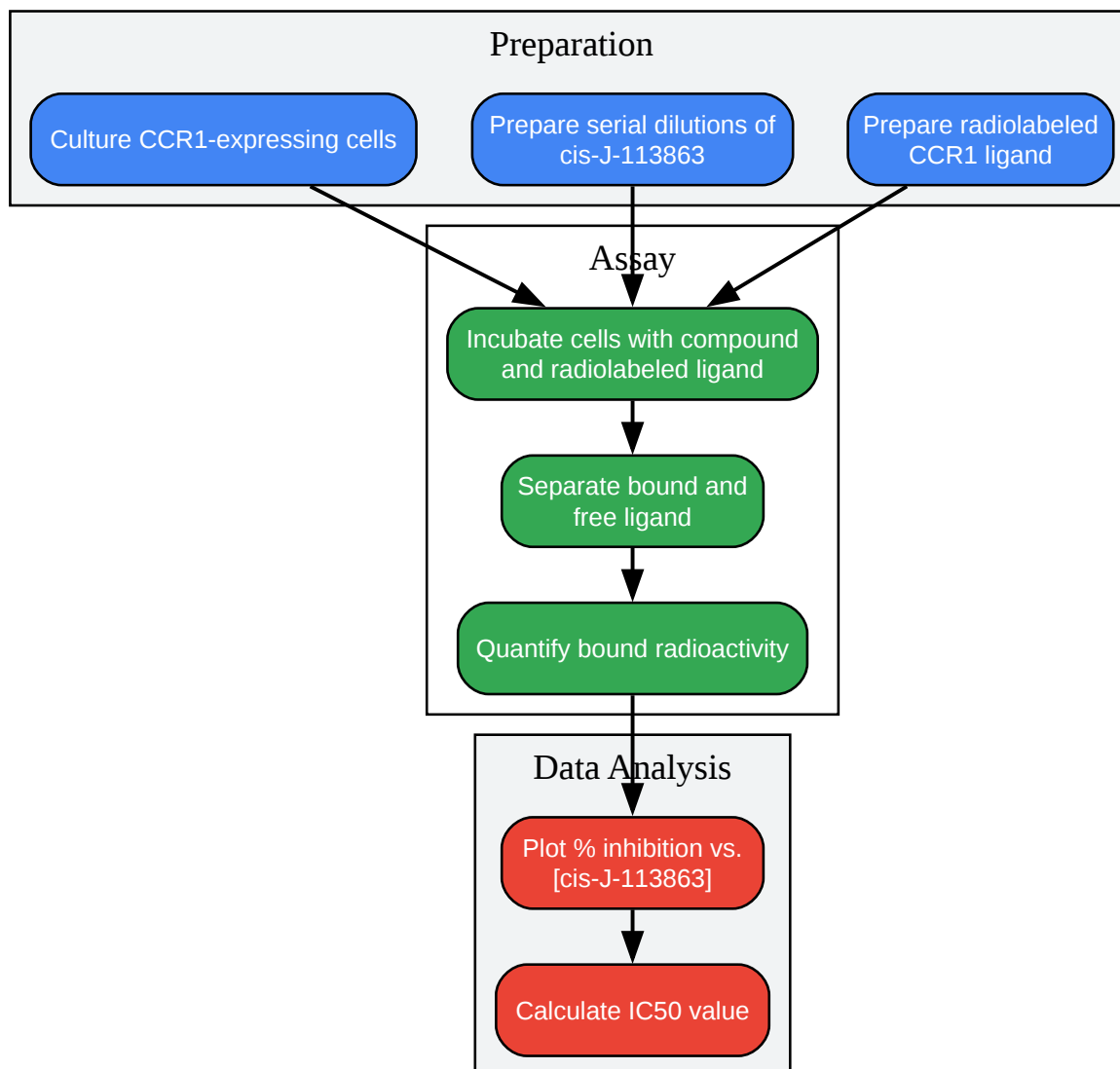

[Click to download full resolution via product page](#)

### Need Custom Synthesis?

BenchChem offers custom synthesis for rare earth carbides and specific isotopic labeling.

Email: [info@benchchem.com](mailto:info@benchchem.com) or [Request Quote Online](#).

## References

- 1. [medchemexpress.com](http://medchemexpress.com) [[medchemexpress.com](http://medchemexpress.com)]

- [2. rndsystems.com \[rndsystems.com\]](https://rndsystems.com)
- [3. medchemexpress.com \[medchemexpress.com\]](https://medchemexpress.com)
- [4. Partial Agonist and Biased Signaling Properties of the Synthetic Enantiomers J113863/UCB35625 at Chemokine Receptors CCR2 and CCR5 - PMC \[pmc.ncbi.nlm.nih.gov\]](#)
- [5. CCR1 antagonist J-113863 corrects the imbalance of pro- and anti-inflammatory cytokines in a SJL/J mouse model of relapsing-remitting multiple sclerosis - PubMed \[pubmed.ncbi.nlm.nih.gov\]](#)
- [6. researchgate.net \[researchgate.net\]](https://researchgate.net)
- To cite this document: BenchChem. [Reproducibility of cis-J-113863: A Comparative Guide]. BenchChem, [2026]. [Online PDF]. Available at: [\[https://www.benchchem.com/product/b2807753/docs#reproducibility-of-cis-j-113863-a-comparative-guide\]](https://www.benchchem.com/product/b2807753/docs#reproducibility-of-cis-j-113863-a-comparative-guide)

---

#### Disclaimer & Data Validity:

The information provided in this document is for Research Use Only (RUO) and is strictly not intended for diagnostic or therapeutic procedures. While BenchChem strives to provide accurate protocols, we make no warranties, express or implied, regarding the fitness of this product for every specific experimental setup.

**Technical Support:** The protocols provided are for reference purposes. Unsure if this reagent suits your experiment?

**Need Industrial/Bulk Grade?** [Request Custom Synthesis Quote](#)

## BenchChem

Our mission is to be the trusted global source of essential and advanced chemicals, empowering scientists and researchers to drive progress in science and industry.

#### Contact

Address: 3281 E Guasti Rd

Ontario, CA 91761, United States

Phone: (601) 213-4426

Email: [info@benchchem.com](mailto:info@benchchem.com)

Contact our Ph.D. Support Team for a compatibility check