

Navigating the Challenges of Amide Coupling with Electron-Deficient Benzamides: An Application Note

Author: BenchChem Technical Support Team. **Date:** April 2026

Compound of Interest

Compound Name: 2,4,6-trifluoro-N-methylbenzamide

CAS No.: 613678-12-9

Cat. No.: B2795027

[Get Quote](#)

For Researchers, Scientists, and Drug Development Professionals

Introduction: The Unique Challenge of Electron-Deficient Systems

Amide bond formation is a cornerstone of organic synthesis, particularly in medicinal chemistry and drug development.^{[1][2]} While numerous protocols exist for standard amide couplings, the synthesis of benzamides derived from electron-deficient benzoic acids or anilines presents a significant challenge. The reduced nucleophilicity of electron-poor anilines and the decreased reactivity of the carbonyl carbon in electron-deficient benzoic acids often lead to sluggish reactions, low yields, and the need for harsh conditions that can compromise complex molecular scaffolds.^{[1][3][4]} This application note provides a detailed guide to understanding and overcoming these challenges, offering field-proven protocols and insights into the selection of appropriate coupling reagents and reaction conditions.

Understanding the Mechanistic Hurdles

The core of the problem lies in the electronic properties of the substrates. Electron-withdrawing groups on the benzoic acid ring deactivate the carbonyl group, making it less susceptible to nucleophilic attack. Conversely, similar groups on an aniline starting material diminish the electron density on the nitrogen atom, rendering it a weaker nucleophile.[3] Standard coupling methods that are effective for electron-rich or sterically unhindered substrates often fail or provide unsatisfactory results in these cases.[4][5]

Success in these challenging couplings hinges on the appropriate activation of the carboxylic acid. This is typically achieved by converting the carboxylic acid into a more reactive species, such as an active ester, acyl fluoride, or acyliminium ion, which can then be more readily attacked by the weakly nucleophilic amine.[1][6]

Strategic Approaches to Coupling Electron-Deficient Benzamides

Several classes of coupling reagents have proven effective for these difficult transformations. The choice of reagent and protocol depends on the specific substrates, their steric and electronic properties, and the desired scale of the reaction.

Uronium/Aminium and Phosphonium Salt-Based Reagents

Uronium/aminium salts like HATU, HBTU, and COMU, as well as phosphonium salts such as PyBOP and PyAOP, are highly efficient activating agents.[3][7] They react with the carboxylic acid to form highly reactive OAt/OBt active esters, which readily couple with even weakly nucleophilic amines.[8]

- HATU (1-[Bis(dimethylamino)methylene]-1H-1,2,3-triazolo[4,5-b]pyridinium 3-oxid hexafluorophosphate) is particularly effective due to the formation of a highly reactive OAt ester and the anchimeric assistance provided by the pyridine nitrogen, which accelerates the coupling reaction.[7] It is often the reagent of choice for difficult couplings, including those involving sterically hindered and electron-deficient partners.[3][9]
- PyBOP ((Benzotriazol-1-yloxy)tripyrrolidinophosphonium hexafluorophosphate) is another powerful phosphonium-based reagent that is well-suited for sterically demanding couplings.

[3] A key advantage of phosphonium salts is that they do not react with the amine component, which can be an issue with some uronium reagents.[6][7]

- COMU ((1-Cyano-2-ethoxy-2-oxoethylideneaminoxy)dimethylamino-morpholino-carbenium hexafluorophosphate) is a newer generation uronium salt that offers high reactivity, comparable to HATU, with the added benefit of safer, non-explosive byproducts.[10][11]

Key Considerations:

- Base Selection: The use of a non-nucleophilic, sterically hindered base like diisopropylethylamine (DIPEA) or 2,4,6-collidine is crucial to prevent side reactions.[9]
- Pre-activation: Allowing the carboxylic acid to react with the coupling reagent and base for a short period (pre-activation) before adding the amine can sometimes improve yields.[3][9]

Diagram 1: General Workflow for Uronium/Phosphonium-Mediated Coupling

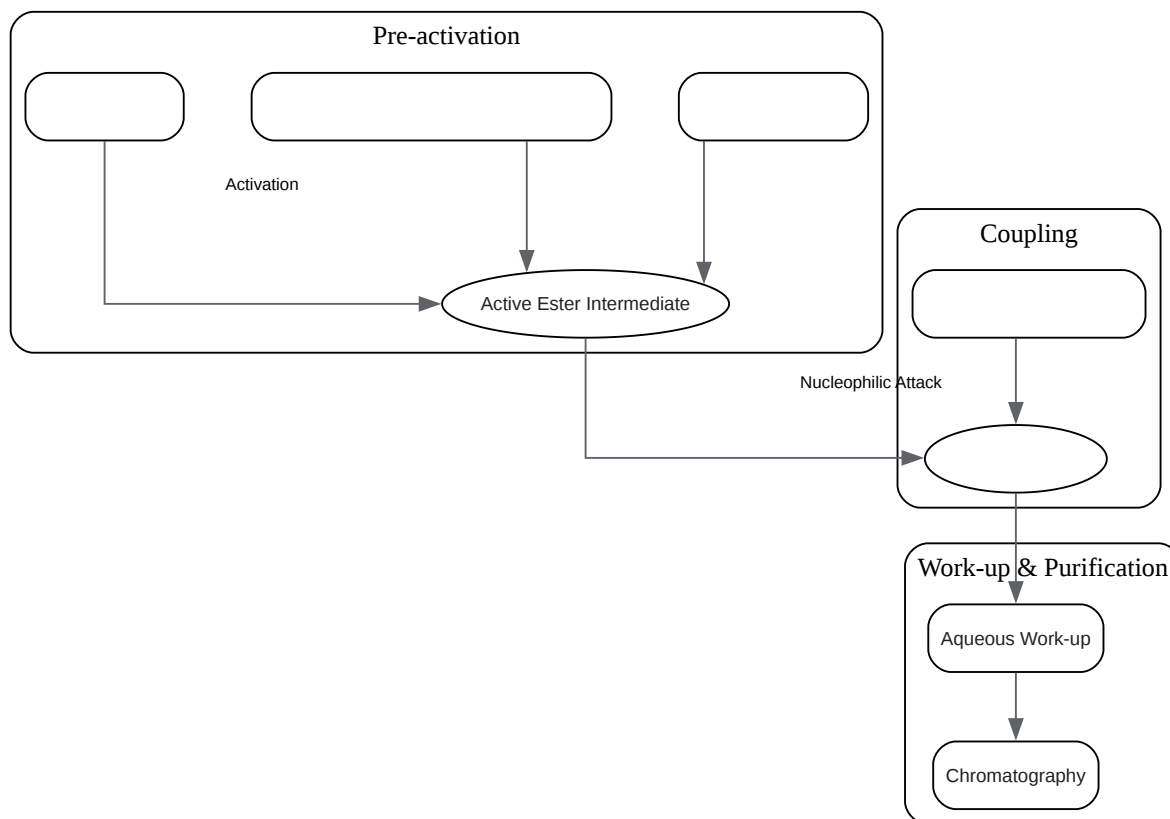

[Click to download full resolution via product page](#)

Caption: A generalized workflow for amide coupling using uronium or phosphonium reagents.

Carbodiimide-Based Protocols with Additives

Carbodiimides, such as 1-ethyl-3-(3-dimethylaminopropyl)carbodiimide (EDC) and dicyclohexylcarbodiimide (DCC), are widely used and cost-effective coupling reagents.[8][12] However, for electron-deficient substrates, they often require the use of additives to enhance efficiency and suppress side reactions like the formation of N-acylurea.[3][11]

- EDC/HOBt/DMAP Protocol: A particularly effective method for coupling electron-deficient anilines involves the use of EDC in combination with 1-hydroxybenzotriazole (HOBt) and a catalytic amount of 4-(dimethylamino)pyridine (DMAP).[1] In this system, EDC and HOBt form a reactive HOBt ester. DMAP then acts as an acyl transfer agent, forming a highly reactive acyliminium ion intermediate that readily reacts with the weakly nucleophilic amine. [1]

Key Considerations:

- Solvent: Aprotic polar solvents like acetonitrile (AcCN) or dichloromethane (DCM) are generally preferred.[1][3]
- Stoichiometry: The use of stoichiometric amounts of EDC and DMAP with a catalytic amount of HOBt has been shown to provide optimal results.[1]

Diagram 2: Proposed Mechanism for EDC/HOBt/DMAP Mediated Coupling

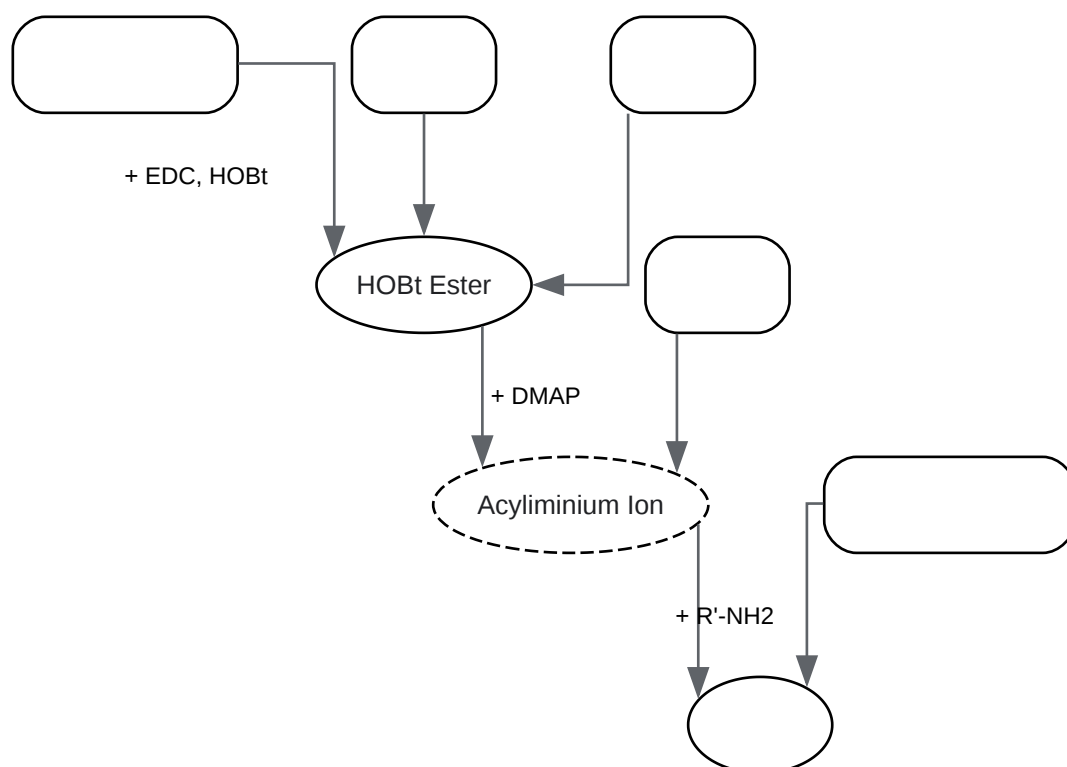

[Click to download full resolution via product page](#)

Caption: The proposed catalytic cycle for the EDC/HOBt/DMAP amide coupling protocol.

Acyl Fluoride-Mediated Coupling

For exceptionally challenging couplings, particularly those involving both sterically hindered and electron-deficient substrates, the in situ formation of acyl fluorides offers a highly effective strategy.^{[4][5][13]} Reagents like BTFFH (Bis(tetramethylene)fluoroformamidinium hexafluorophosphate) can convert carboxylic acids into their corresponding acyl fluorides, which are highly reactive towards even poor nucleophiles.^[14] This method often succeeds where other standard protocols fail.^{[4][5][13]}

Key Considerations:

- **Elevated Temperatures:** These reactions are often performed at elevated temperatures, sometimes with the aid of microwave irradiation, to drive the reaction to completion.^{[14][15]}
- **Anhydrous Conditions:** Strict anhydrous conditions are necessary to prevent hydrolysis of the highly reactive acyl fluoride intermediate.^[14]

Comparative Summary of Protocols

Protocol	Coupling Reagent(s)	Additive(s)	Key Advantages	Potential Drawbacks
Uronium/Phosphonium	HATU, PyBOP, COMU	None typically required	High reactivity, low racemization, effective for hindered substrates.[3][9]	Higher cost, potential for side reactions with some uronium reagents.[3][7]
Carbodiimide	EDC, DCC	HOBt, DMAP	Cost-effective, readily available reagents.[1][8]	Can form N-acylurea byproducts, DCC byproduct removal can be difficult.[1][3]
Acyl Fluoride	BTFFH, TFFH	None	Highly effective for very challenging and sterically hindered substrates.[4][5]	Requires anhydrous conditions and often elevated temperatures.[14]

Experimental Protocols

Protocol 1: HATU-Mediated Coupling of an Electron-Deficient Benzamide

This protocol provides a general method for the acylation of an electron-deficient amine with an electron-deficient benzoic acid using HATU.[9]

Materials:

- Electron-deficient benzoic acid (1.0 eq)
- Electron-deficient amine (1.0-1.2 eq)
- HATU (1.1-1.3 eq)

- DIPEA (2.0-3.0 eq)
- Anhydrous DMF or DCM

Procedure:

- To a solution of the electron-deficient benzoic acid in anhydrous DMF, add HATU and DIPEA.
- Stir the mixture at room temperature for 15-30 minutes to pre-activate the acid.
- Add the electron-deficient amine to the reaction mixture.
- Stir the reaction at room temperature and monitor its progress by TLC or LC-MS. For particularly sluggish reactions, gentle heating (40-50 °C) may be beneficial.
- Upon completion, dilute the reaction mixture with ethyl acetate and wash sequentially with 1N HCl, saturated NaHCO₃ solution, and brine.
- Dry the organic layer over anhydrous Na₂SO₄, filter, and concentrate under reduced pressure.
- Purify the crude product by flash column chromatography.

Protocol 2: EDC/HOBt/DMAP Coupling for Electron-Deficient Anilines

This protocol is adapted from a demonstrated efficient method for the synthesis of amide derivatives with electron-deficient and unreactive amines.[\[1\]](#)

Materials:

- Carboxylic acid (1.2 eq)
- Electron-deficient aniline (1.0 eq)
- EDC (1.0 eq)
- HOBt (0.1 eq)

- DMAP (1.0 eq)
- Anhydrous acetonitrile (AcCN)

Procedure:

- To a stirred solution of the electron-deficient aniline in anhydrous AcCN, add the carboxylic acid, EDC, HOBT, and DMAP.
- Stir the resulting mixture at room temperature.
- Monitor the progress of the reaction by TLC.
- After completion of the reaction, concentrate the reaction mixture under reduced pressure.
- Purify the residue by flash column chromatography to afford the desired amide derivative.

Protocol 3: Acyl Fluoride Formation with BTFFH for Challenging Couplings

This protocol is based on a method developed for sterically hindered and electron-deficient substrates.^[14]

Materials:

- Carboxylic acid (1.3 eq)
- BTFFH (1.5 eq)
- DIPEA (4.5 eq)
- Electron-deficient amine (1.0 eq)
- Anhydrous CH₂Cl₂
- Microwave vial (optional, for elevated temperature)

Procedure:

- In a dry vial under an argon atmosphere, dissolve the carboxylic acid and BTFFH in anhydrous CH_2Cl_2 .
- Add DIPEA and stir the reaction mixture under argon for 30 minutes.
- Add the electron-deficient amine.
- Seal the vial and heat in an oil bath at 80 °C overnight (or use a microwave reactor for accelerated reaction times).
- Cool the reaction mixture to room temperature, dilute with water, and extract with ethyl acetate (3x).
- Combine the organic layers, dry over anhydrous Na_2SO_4 , filter, and concentrate.
- Purify the crude product by flash chromatography.

Troubleshooting and Optimization

- **Low Yield:** If low yields are observed, consider increasing the reaction temperature or switching to a more potent activating agent (e.g., from EDC/HOBt to HATU or BTFFH).[3] Microwave irradiation can also significantly improve yields and reduce reaction times for sluggish couplings.[15][16][17]
- **Side Reactions:** The formation of byproducts can often be minimized by careful control of stoichiometry, temperature, and the order of addition of reagents. Using phosphonium-based reagents like PyBOP can avoid the guanidinylation side reaction sometimes observed with uronium salts.[7]
- **Racemization:** For chiral carboxylic acids, racemization can be a concern, especially at elevated temperatures or with strong bases. Using additives like HOBt or HOAt can help to suppress epimerization.[8][11]

Conclusion

The successful synthesis of electron-deficient benzamides requires a departure from standard amide coupling protocols. By understanding the underlying electronic challenges and selecting the appropriate high-activity coupling reagents and optimized conditions, researchers can

effectively overcome these hurdles. The use of powerful uronium or phosphonium reagents, tailored carbodiimide protocols with activating additives, or the in situ generation of highly reactive acyl fluorides provides a robust toolkit for accessing these important and often challenging amide derivatives. Careful consideration of the specific substrates and a willingness to explore different protocols will ultimately lead to successful and efficient amide bond formation.

References

- A Protocol for Amide Bond Formation with Electron Deficient Amines and Sterically Hindered Substr
- Amide bond formation: beyond the myth of coupling reagents. Luxembourg Bio Technologies.
- A protocol for amide bond formation with electron deficient amines and sterically hindered substrates. Organic & Biomolecular Chemistry (RSC Publishing).
- Synthesis of amide derivatives for electron deficient amines and functionalized carboxylic acids using EDC and DMAP and a catalytic amount of HOBt as the coupling reagents. PMC.
- Technical Support Center: Amide Coupling Reactions with Electron-Rich Amines. Benchchem.
- Coupling Reagents. AAPPTEC - Peptides.
- A protocol for amide bond formation with electron deficient amines and sterically hindered substr
- Microwave-Assisted Catalytic Method for a Green Synthesis of Amides Directly
- Rapid Mechanochemical Synthesis of Amides with Uronium-Based Coupling Reagents, a Method for Hexa-amidation of Biotin[8]uril. ChemRxiv.
- 21.7: Chemistry of Amides. Chem LibreTexts.
- The amide group and its preparation methods by acid-amine coupling reactions: an overview.
- Efficient Peptide Synthesis: A Guide to Coupling Reagents & Additives. Bachem.
- Rapid Mechanochemical Synthesis of Amides with Uronium-Based Coupling Reagents, a Method for Hexa-amidation of Biotin[8]uril. ResearchGate.
- Peptide Coupling Reagents Guide. Sigma-Aldrich.
- A protocol for amide bond formation with electron deficient amines and sterically hindered substrates. University of Copenhagen Research Portal.
- Amide coupling reaction in medicinal chemistry. Coupling reagents.

- A Protocol for Amide Bond Formation with Electron Deficient Amines and Sterically Hindered Substrates.
- Peptide Coupling Reagents, More than a Letter Soup. Chemical Reviews.
- Carbodiimide Crosslinker Chemistry: EDC and DCC.
- Technical Support Center: Alternative Coupling Reagents for Sterically Hindered N-Methyl Amines. Benchchem.
- Flow-to-Flow Technology: Amide Formation in the Absence of Traditional Coupling Reagents Using DPDTC. ACS Sustainable Chemistry & Engineering.
- Peptide Coupling Reagents Guide. MilliporeSigma.
- Microwave-assisted One-pot Synthesis of Amide Bond using WEB. Bentham Science.
- Microwave-assisted direct amidation of thioesters: a green approach. Organic & Biomolecular Chemistry (RSC Publishing).
- Amide synthesis by acyl
- Microwave-Assisted Synthesis of Amide under Solvent-free Conditions.
- Carbodiimide Crosslinker Chemistry. Thermo Fisher Scientific - US.
- Microwave-Assisted Buchwald–Hartwig Double Amination: A Rapid and Promising Approach for the Synthesis of TADF Compounds.
- Formation of amides: one-pot condensation of carboxylic acids and amines medi
- Tips and tricks for difficult amide bond form

Need Custom Synthesis?

BenchChem offers custom synthesis for rare earth carbides and specific isotopic labeling.

Email: info@benchchem.com or [Request Quote Online](#).

Sources

- [1. Synthesis of amide derivatives for electron deficient amines and functionalized carboxylic acids using EDC and DMAP and a catalytic amount of HOBT as the coupling reagents - PMC \[pmc.ncbi.nlm.nih.gov\]](#)
- [2. researchgate.net \[researchgate.net\]](#)
- [3. benchchem.com \[benchchem.com\]](#)
- [4. findresearcher.sdu.dk:8443 \[findresearcher.sdu.dk:8443\]](#)
- [5. pubs.rsc.org \[pubs.rsc.org\]](#)
- [6. hepatochem.com \[hepatochem.com\]](#)

- [7. 肽偶联剂选择指南 \[sigmaaldrich.com\]](#)
- [8. peptide.com \[peptide.com\]](#)
- [9. pdf.benchchem.com \[pdf.benchchem.com\]](#)
- [10. chemrxiv.org \[chemrxiv.org\]](#)
- [11. bachem.com \[bachem.com\]](#)
- [12. Carbodiimide Crosslinker Chemistry: EDC and DCC - Creative Proteomics \[creative-proteomics.com\]](#)
- [13. researchprofiles.ku.dk \[researchprofiles.ku.dk\]](#)
- [14. rsc.org \[rsc.org\]](#)
- [15. Microwave-Assisted Catalytic Method for a Green Synthesis of Amides Directly from Amines and Carboxylic Acids - PMC \[pmc.ncbi.nlm.nih.gov\]](#)
- [16. benthamscience.com \[benthamscience.com\]](#)
- [17. pubs.acs.org \[pubs.acs.org\]](#)
- [To cite this document: BenchChem. \[Navigating the Challenges of Amide Coupling with Electron-Deficient Benzamides: An Application Note\]. BenchChem, \[2026\]. \[Online PDF\]. Available at: \[https://www.benchchem.com/product/b2795027/docs#navigating-the-challenges-of-amide-coupling-with-electron-deficient-benzamides-an-application-note\]](#)

Disclaimer & Data Validity:

The information provided in this document is for Research Use Only (RUO) and is strictly not intended for diagnostic or therapeutic procedures. While BenchChem strives to provide accurate protocols, we make no warranties, express or implied, regarding the fitness of this product for every specific experimental setup.

Technical Support: The protocols provided are for reference purposes. Unsure if this reagent suits your experiment?

Need Industrial/Bulk Grade? [Request Custom Synthesis Quote](#)

BenchChem

Our mission is to be the trusted global source of essential and advanced chemicals, empowering scientists and researchers to drive progress in science and industry.

Contact

Address: 3281 E Guasti Rd
Ontario, CA 91761, United States
Phone: (601) 213-4426
Email: info@benchchem.com

[Contact our Ph.D. Support Team for a compatibility check](#)