

Comparative Guide to Mass Spectrometry Fragmentation of Thiazole Derivatives

Author: BenchChem Technical Support Team. **Date:** April 2026

Compound of Interest

Compound Name:	<i>N</i> -methyl-4-phenyl-1,3-thiazol-2-amine
CAS No.:	6142-11-6
Cat. No.:	B2789229

[Get Quote](#)

Executive Summary & Strategic Importance

Thiazole rings are pharmacophores of immense significance, anchoring blockbuster drugs like Ritonavir (antiretroviral), Dasatinib (antineoplastic), and Tiazofurin.[1] However, their structural characterization poses a distinct challenge: the aromatic stability of the thiazole ring often resists fragmentation under soft ionization (ESI), while producing complex rearrangement patterns under hard ionization (EI).

This guide objectively compares the fragmentation behaviors of thiazole derivatives against their structural isomers (oxazoles, isothiazoles) and contrasts the utility of Electron Ionization (EI) versus Electrospray Ionization (ESI-CID). It provides a validated workflow to distinguish these moieties in unknown metabolites or synthetic impurities.

Theoretical Framework: The Physics of the Ring

The fragmentation logic of thiazole (

) is governed by the relative bond strengths and the "softness" of the sulfur atom compared to nitrogen.

- Aromaticity: The thiazole ring is

-excessive but less stable than benzene.
- Weakest Links: The C-S bonds are longer and weaker than C-N or C-C bonds, making them the primary sites for ring opening.
- Nitrogen Influence: The lone pair on nitrogen facilitates protonation in ESI, directing charge-remote fragmentation.

Comparative Stability Metrics (Bond Dissociation Energy Estimates)

Bond Type	Approx. Energy (kJ/mol)	Implication for MS
C=N	615	Highly stable; rarely breaks first.
C-S	272	Primary cleavage site (Ring opening).
C-O (Oxazole)	358	Oxazoles are harder to ring-open at the heteroatom than thiazoles.

Comparative Analysis: Thiazole vs. Isomeric Alternatives

Distinguishing thiazoles from oxazoles or isothiazoles is a common analytical problem. The following table contrasts their characteristic mass spectral signatures.

Table 1: Differential Fragmentation Signatures[2]

Feature	Thiazole ()	Oxazole ()	Isothiazole ()
Molecular Weight	85 Da	69 Da	85 Da
Primary Neutral Loss	HCN (27 Da) & CS (44 Da)	CO (28 Da) & HCN (27 Da)	HCN (27 Da)
Diagnostic Fragment	58 (Thiirene cation)	42 (Ketene-like)	53 (equivalent)
Ring Cleavage	C(2)-S bond rupture	C(2)-O bond rupture	N-S bond rupture (Weakest)
Isotopic Pattern	Distinct peak (~4.4%)	No significant M+2	Distinct peak (~4.4%)

“

Critical Insight: To distinguish Thiazole from Isothiazole, look for the N-S cleavage. Isothiazoles possess a weak N-S bond that cleaves readily to form intense nitrile-sulfide fragments, whereas thiazoles require C-S cleavage.

Deep Dive: Fragmentation Mechanisms[3]

Understanding the mechanism allows for the prediction of fragments in novel derivatives.

Mechanism A: The HCN Loss (The "Classic" Pathway)

This is the dominant pathway in EI. The ring opens, followed by the expulsion of Hydrogen Cyanide (HCN), typically involving the C2 carbon and the ring nitrogen.

Mechanism B: Retro-Diels-Alder (RDA)

In 2-substituted thiazoles, the ring can mimic a diene system. Under thermal stress (GC-MS) or high collision energy (CID), the ring undergoes an RDA-like collapse.

Visualization of Pathways

The following diagram illustrates the competing pathways for a generic 2-substituted thiazole.

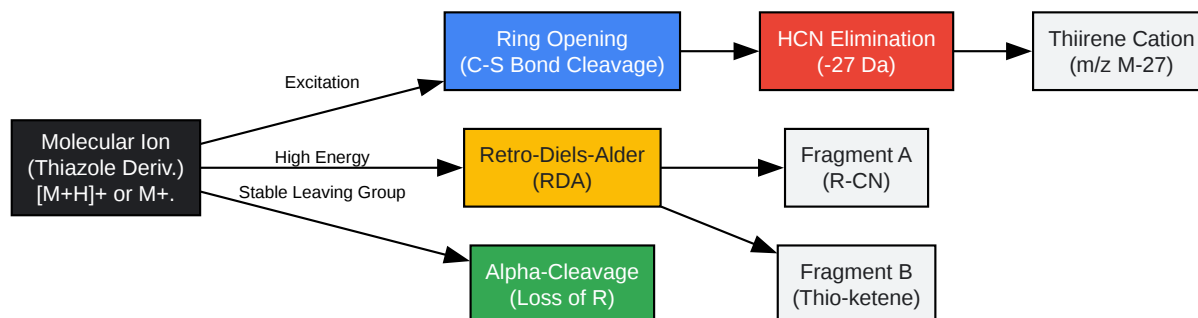

[Click to download full resolution via product page](#)

Figure 1: Competing fragmentation pathways for thiazole derivatives. The C-S bond cleavage is the rate-limiting step for ring opening.

Experimental Protocol: Self-Validating Workflow

To ensure reproducibility, this protocol includes a "System Suitability" step using Sulfathiazole as a benchmark.

Materials

- Standard: Sulfathiazole (Sigma-Aldrich/Merck).
- Solvents: LC-MS grade Methanol (MeOH) and Formic Acid (FA).
- Instrument: Q-TOF or Triple Quadrupole (QqQ).

Step-by-Step Methodology

Phase 1: System Suitability (Mandatory)

- Preparation: Dissolve Sulfathiazole to 1 µg/mL in 50:50 MeOH:H₂O + 0.1% FA.

- Direct Infusion: Infuse at 10 $\mu\text{L}/\text{min}$.
- Precursor Scan: Select
256.0 (
).
- Energy Ramp: Ramp Collision Energy (CE) from 10 to 50 eV.
- Validation Criteria: You must observe the characteristic transition

256

156 (Loss of aminobenzenesulfonyl group) and

156

92 (Thiazole ring fragmentation).

- If

92 is absent: Your CE is too low for thiazole ring characterization. Increase CE.

Phase 2: Unknown Analysis (Thiazole Derivative)

- Ionization Source:
 - Use ESI (+) for polar derivatives (amines, amides).
 - Use APCI (+) if the derivative is non-polar (e.g., phenyl-thiazoles lacking basic nitrogens).
- MS2 Acquisition:
 - Apply the "Stepped CE" method: Acquire spectra at 20, 35, and 50 eV simultaneously.
 - Reasoning: Low energy preserves the substituent information; high energy (50 eV) is required to shatter the thiazole ring (RDA/HCN loss).
- Data Interpretation:

- Look for the "Sulfur Defect": A mass defect near -0.02 Da relative to hydrocarbons.
- Check for Neutral Loss of 27 (HCN). If observed, the ring is likely intact in the precursor.

Decision Tree for Structural Assignment

Use this logic flow to interpret your MS/MS spectra.

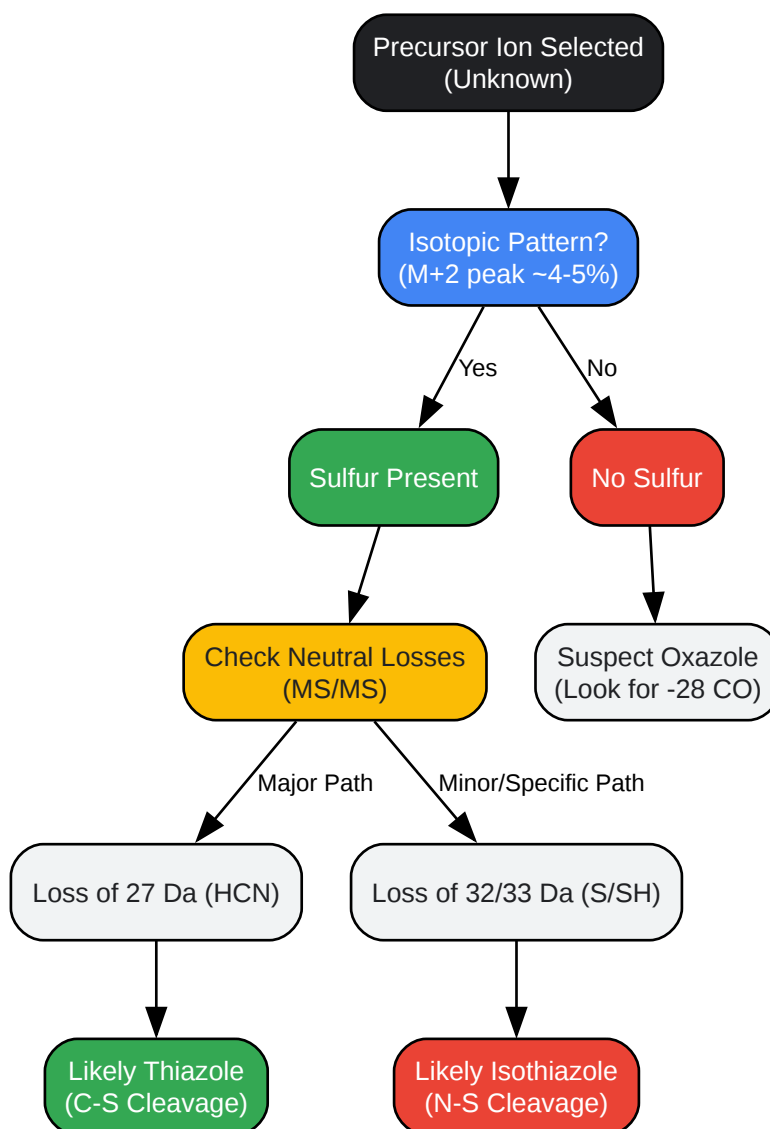

[Click to download full resolution via product page](#)

Figure 2: Decision tree for distinguishing 5-membered heterocyclic rings.

References

- NIST Mass Spectrometry Data Center. (n.d.). Thiazole - EI Mass Spectrum. National Institute of Standards and Technology. [[Link](#)]
- Bayer, E., et al. (2023). "Differentiation between Isomeric 4,5-Functionalized 1,2,3-Thiadiazoles and 1,2,3-Triazoles by ESI-HRMS." *Molecules*. [[Link](#)][[2](#)][[3](#)][[4](#)][[5](#)][[6](#)]
- Salem, M. A. I., et al. (2014).[[7](#)] "Mass Spectral Fragmentation Modes of Some New Pyrimidinethiones and Thiazolo-Pyrimidines." *International Journal of Materials and Chemistry*. [[Link](#)]
- Master Organic Chemistry. (2018). "The Retro-Diels-Alder Reaction." [[Link](#)]
- MetwareBio. (n.d.). "Top 6 Ion Sources in Mass Spectrometry: EI vs ESI." [[Link](#)]

Need Custom Synthesis?

BenchChem offers custom synthesis for rare earth carbides and specific isotopic labeling.

Email: info@benchchem.com or [Request Quote Online](#).

Sources

- [1. pdfs.semanticscholar.org](https://pdfs.semanticscholar.org) [pdfs.semanticscholar.org]
- [2. An Organic Chemist's Guide to Electrospray Mass Spectrometric Structure Elucidation - PMC](https://pubmed.ncbi.nlm.nih.gov/) [[pmc.ncbi.nlm.nih.gov](https://pubmed.ncbi.nlm.nih.gov/)]
- [3. researchgate.net](https://www.researchgate.net) [[researchgate.net](https://www.researchgate.net)]
- [4. Fragmentation \(mass spectrometry\) - Wikipedia](https://en.wikipedia.org/wiki/Fragmentation_(mass_spectrometry)) [[en.wikipedia.org](https://en.wikipedia.org/wiki/Fragmentation_(mass_spectrometry))]
- [5. Top 6 Ion Sources in Mass Spectrometry: EI, CI, ESI, APCI, APPI, and MALDI - MetwareBio](https://www.metwarebio.com) [[metwarebio.com](https://www.metwarebio.com)]
- [6. masterorganicchemistry.com](https://www.masterorganicchemistry.com) [[masterorganicchemistry.com](https://www.masterorganicchemistry.com)]
- [7. article.sapub.org](https://www.article.sapub.org) [[article.sapub.org](https://www.article.sapub.org)]
- To cite this document: BenchChem. [[Comparative Guide to Mass Spectrometry Fragmentation of Thiazole Derivatives](#)]. BenchChem, [2026]. [[Online PDF](#)]. Available at: [<https://www.benchchem.com/product/b2789229/docs#comparative-guide-to-mass-spectrometry-fragmentation-of-thiazole-derivatives>]

Disclaimer & Data Validity:

The information provided in this document is for Research Use Only (RUO) and is strictly not intended for diagnostic or therapeutic procedures. While BenchChem strives to provide accurate protocols, we make no warranties, express or implied, regarding the fitness of this product for every specific experimental setup.

Technical Support: The protocols provided are for reference purposes. Unsure if this reagent suits your experiment?

Need Industrial/Bulk Grade? [Request Custom Synthesis Quote](#)

BenchChem

Our mission is to be the trusted global source of essential and advanced chemicals, empowering scientists and researchers to drive progress in science and industry.

Contact

Address: 3281 E Guasti Rd
Ontario, CA 91761, United States
Phone: (601) 213-4426
Email: info@benchchem.com

[Contact our Ph.D. Support Team for a compatibility check](#)