

Application Note: Precision N-Arylation of 1,2,3-Triazoles

Author: BenchChem Technical Support Team. **Date:** April 2026

Compound of Interest

Compound Name:	1-(3-fluoro-4-methylphenyl)-1H-1,2,3-triazole
CAS No.:	2137687-93-3
Cat. No.:	B2789479

[Get Quote](#)

Executive Summary

The 1,2,3-triazole moiety is a cornerstone pharmacophore in medicinal chemistry, functioning as a bioisostere for amide bonds and a linker in fragment-based drug discovery. However, the post-synthetic N-arylation of the 1,2,3-triazole ring presents a significant regioselectivity challenge.^{[1][2]} The ring exists in a tautomeric equilibrium between the N1-H and N2-H forms, with three potential nucleophilic nitrogen atoms (N1, N2, N3).

Direct arylation typically favors the N2-isomer due to thermodynamic stability and specific metal-coordination dynamics. Conversely, the N1-isomer is kinetically favored during ring formation but difficult to access via direct arylation of the pre-formed ring.

This guide details two validated protocols for N2-selective arylation (Palladium-catalyzed and Metal-free) and provides a strategic directive for accessing N1-aryl derivatives.

Mechanistic Insight & Regioselectivity

The Tautomer Challenge

In solution, 4-substituted-1,2,3-triazoles exist in rapid equilibrium. While the N2-arylated product is often the thermodynamic sink (due to preserved aromaticity and minimized steric clash), kinetic factors in metal-catalyzed cross-couplings can be tuned.

- Copper Catalysis (Ullmann-type): Generally yields mixtures (N2:N1 ratio ~ 4:1) because the copper intermediate can coordinate to both N1 and N2, often directed by steric bulk at C4.
- Palladium Catalysis (Buchwald-Hartwig): Utilizing bulky biaryl phosphine ligands (e.g., Me4tBuXPhos) enforces high N2-selectivity (>95%). The steric bulk of the ligand destabilizes the N1-bound palladium complex, favoring reductive elimination from the less hindered N2-species.
- Metal-Free (SNAr/Hypervalent Iodine): Driven purely by thermodynamics, exclusively yielding the N2-isomer.

Visualization: Regioselectivity Pathways

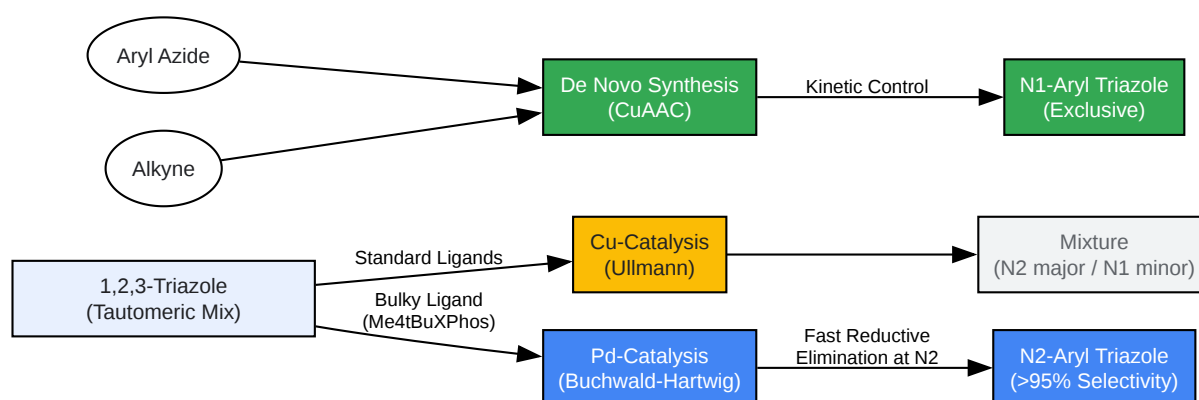

[Click to download full resolution via product page](#)

Figure 1: Decision tree for selecting the correct synthetic pathway based on the desired regioisomer.

Protocol A: Highly N2-Selective Palladium-Catalyzed Arylation

Best For: Complex substrates, late-stage functionalization, and when >95% regioselectivity is required. Mechanism: Buchwald-Hartwig Cross-Coupling.[3]

Reagents & Equipment

- Catalyst Source: Tris(dibenzylideneacetone)dipalladium(0) [Pd₂(dba)₃]
- Ligand: Me₄tBuXPhos (di-tert-butyl(2',4',6'-triisopropyl-3,4,5,6-tetramethyl-[1,1'-biphenyl]-2-yl)phosphine).[4] Critical for selectivity.
- Base: Potassium Phosphate Tribasic (K₃PO₄), anhydrous.
- Solvent: Toluene (anhydrous, degassed).
- Reaction Vessel: Sealed Schlenk tube or pressure vial.

Step-by-Step Procedure

- Preparation (Glovebox or Schlenk Line):
 - In a reaction vial equipped with a magnetic stir bar, add 1,2,3-triazole (1.2 equiv), Aryl Bromide/Chloride (1.0 equiv), K₃PO₄ (2.0 equiv).
 - Add Pd₂(dba)₃ (0.5 – 1.0 mol%) and Me₄tBuXPhos (1.0 – 2.0 mol%). Note: A Pd:Ligand ratio of 1:2 is optimal.
- Solvent Addition:
 - Evacuate and backfill with Argon (3 cycles).
 - Add anhydrous Toluene (concentration ~0.2 M with respect to aryl halide).
- Reaction:
 - Seal the vessel tightly.
 - Heat to 100–120 °C for 5–12 hours. Monitor via LC-MS.

- Checkpoint: The reaction mixture should turn from dark purple/red to a dark brown/black suspension.
- Work-up:
 - Cool to room temperature.[\[5\]](#)[\[6\]](#)[\[7\]](#)[\[8\]](#)[\[9\]](#)
 - Filter through a pad of Celite® to remove insoluble salts; wash with Ethyl Acetate.
 - Concentrate the filtrate under reduced pressure.
- Purification:
 - Purify via flash column chromatography (Hexanes/EtOAc). N2-isomers are typically less polar (higher Rf) than N1-isomers.

Validation Data:

- Selectivity: Expect N2:N1 ratios > 50:1.
- Yield: Typically 80–95%.

Protocol B: Metal-Free N2-Selective Arylation (Green Alternative)

Best For: Avoiding heavy metals, simple substrates, and "Green Chemistry" compliance.

Mechanism: Nucleophilic substitution on hypervalent iodine.

Reagents

- Electrophile: Diaryliodonium salt (e.g., Diphenyliodonium triflate).
- Base: Sodium Carbonate (Na₂CO₃) or Potassium tert-butoxide (KOtBu).
- Solvent: Toluene or DMF.[\[7\]](#)[\[9\]](#)

Step-by-Step Procedure

- Setup:

- Charge a flask with 1,2,3-triazole (1.0 equiv), Diaryliodonium salt (1.2 equiv), and Na₂CO₃ (2.0 equiv).
- Reaction:
 - Add Toluene (0.1 M).
 - Heat to 100 °C under an inert atmosphere for 12–24 hours.
- Work-up:
 - Dilute with water and extract with Dichloromethane (DCM).
 - Wash organic layer with brine, dry over MgSO₄.^[4]
- Purification:
 - Standard flash chromatography.

Expert Note: This method is thermodynamically driven.^[10] Since the N₂-isomer is lower in energy (approx. 3–5 kcal/mol more stable than N₁), the reaction exclusively yields the N₂ product without the need for ligand control.

Strategic Directive: Accessing N₁-Aryl Triazoles

Problem: Direct arylation of the triazole ring to form N₁-isomers is inefficient and lacks selectivity. Solution: Do NOT use direct arylation. Instead, use De Novo Synthesis.

If your target is an N₁-aryl-1,2,3-triazole, you must construct the ring using the Copper-Catalyzed Azide-Alkyne Cycloaddition (CuAAC):

- Synthesize or purchase the corresponding Aryl Azide.
- React with a terminal Alkyne.
- Catalyst: CuSO₄ (1 mol%) + Sodium Ascorbate (10 mol%) in tBuOH/H₂O.
- Result: Exclusive formation of the 1,4-disubstituted N₁-aryl triazole.

Comparative Data Summary

Methodology	Catalyst System	Major Isomer	Selectivity (N2:N1)	Substrate Scope	Key Reference
Buchwald-Hartwig	Pd2(dba)3 / Me4tBuXPhos	N2	> 98:2	Broad (Ar-Cl, Ar-Br)	[1]
Ullmann Coupling	CuI / DMEDA	Mixed	~ 80:20	Moderate (Ar-I)	[2]
Metal-Free	Diaryliodonium / Na2CO3	N2	> 99:1	Limited (Iodonium availability)	[3]
CuAAC (Click)	CuSO4 / Ascorbate	N1	Exclusive	Broad (Azide + Alkyne)	[4]

References

- Highly N2-Selective Palladium-Catalyzed Arylation of 1,2,3-Triazoles. Source: National Institutes of Health (NIH) / PubMed URL:[[Link](#)]
- Copper-Catalyzed "Click" Reaction/Direct Arylation Sequence. Source: Organic Chemistry Portal URL:[[Link](#)]
- Catalyst-Free Regioselective N2 Arylation of 1,2,3-Triazoles Using Diaryl Iodonium Salts. Source: Organic Letters (ACS Publications) URL:[[11](#)][[Link](#)]
- Copper-catalyzed Azide-Alkyne Cycloaddition (CuAAC). Source: Organic Chemistry Portal URL:[[Link](#)]

Need Custom Synthesis?

BenchChem offers custom synthesis for rare earth carbides and specific isotopic labeling.

Email: info@benchchem.com or [Request Quote Online](#).

Sources

- [1. scielo.br \[scielo.br\]](https://scielo.br)
- [2. Highly N2-Selective Palladium-Catalyzed Arylation of 1,2,3-Triazoles - PMC \[pmc.ncbi.nlm.nih.gov\]](#)
- [3. 96%, solid | Sigma-Aldrich \[sigmaaldrich.com\]](#)
- [4. Me3\(OMe\)tBuXPhos: A Surrogate Ligand for Me4tBuXPhos in Palladium-Catalyzed C–N and C–O Bond-Forming Reactions - PMC \[pmc.ncbi.nlm.nih.gov\]](#)
- [5. youtube.com \[youtube.com\]](https://youtube.com)
- [6. benchchem.com \[benchchem.com\]](https://benchchem.com)
- [7. scispace.com \[scispace.com\]](https://scispace.com)
- [8. Chan-Lam Coupling \[organic-chemistry.org\]](#)
- [9. scispace.com \[scispace.com\]](https://scispace.com)
- [10. Catalyst-Free Regioselective N2 Arylation of 1,2,3-Triazoles Using Diaryl Iodonium Salts \[organic-chemistry.org\]](#)
- [11. dspace.mit.edu \[dspace.mit.edu\]](https://dspace.mit.edu)
- To cite this document: BenchChem. [Application Note: Precision N-Arylation of 1,2,3-Triazoles]. BenchChem, [2026]. [Online PDF]. Available at: [\[https://www.benchchem.com/product/b2789479/docs#application-note-precision-n-arylation-of-1-2-3-triazoles\]](https://www.benchchem.com/product/b2789479/docs#application-note-precision-n-arylation-of-1-2-3-triazoles)

Disclaimer & Data Validity:

The information provided in this document is for Research Use Only (RUO) and is strictly not intended for diagnostic or therapeutic procedures. While BenchChem strives to provide accurate protocols, we make no warranties, express or implied, regarding the fitness of this product for every specific experimental setup.

Technical Support: The protocols provided are for reference purposes. Unsure if this reagent suits your experiment?

Need Industrial/Bulk Grade? [Request Custom Synthesis Quote](#)

BenchChem

Our mission is to be the trusted global source of essential and advanced chemicals, empowering scientists and researchers to drive progress in science and industry.

Contact

Address: 3281 E Guasti Rd

Ontario, CA 91761, United States

Phone: (601) 213-4426

Email: info@benchchem.com

[Contact our Ph.D. Support Team for a compatibility check](#)