

Technical Support Center: Optimizing Yield in the α -Alkylation of Proline Derivatives

Author: BenchChem Technical Support Team. **Date:** April 2026

Compound of Interest

Compound Name: (S)-2-allylpyrrolidine hydrochloride

CAS No.: 197230-28-7; 197230-31-2

Cat. No.: B2783374

[Get Quote](#)

Welcome to the Technical Support Center for the α -alkylation of proline derivatives. This guide is designed for researchers, scientists, and drug development professionals to navigate the complexities of this critical synthetic transformation. α -Alkylated proline derivatives are invaluable scaffolds in medicinal chemistry, offering conformational constraints that are crucial for designing potent and selective therapeutics.^{[1][2]} However, achieving high yields and diastereoselectivity can be challenging.

This resource provides in-depth troubleshooting guides, frequently asked questions (FAQs), and validated protocols to help you overcome common hurdles and optimize your reaction outcomes.

Section 1: The Core Reaction: Mechanism and Stereocontrol

The α -alkylation of a proline derivative proceeds via the formation of a nucleophilic enolate, which subsequently attacks an electrophile (typically an alkyl halide) in an SN2-type reaction.^{[3][4]} The stereochemical outcome of the reaction is a critical consideration and is influenced

by factors such as the N-protecting group, the ester group, and the reaction conditions, which dictate the facial selectivity of the electrophile's approach to the enolate.[1]

Below is a generalized mechanism for the α -alkylation of an N-Boc-proline ester.

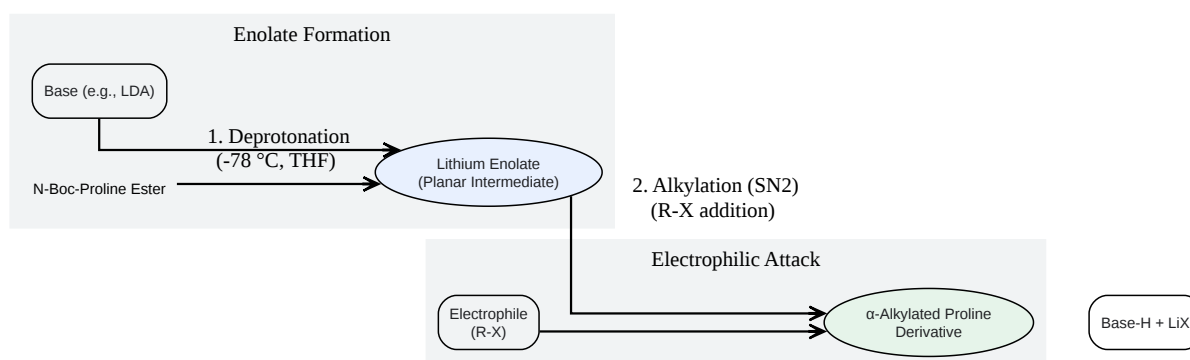

[Click to download full resolution via product page](#)

Caption: General mechanism for the α -alkylation of proline esters.

Section 2: Frequently Asked Questions (FAQs)

Q1: Why is my reaction yield consistently low?

Low yields can stem from several factors:

- **Incomplete Deprotonation:** The base may not be strong enough, or the reaction temperature may be too high, leading to side reactions or equilibrium with the starting material.[5] Ensure you are using a sufficiently strong, non-nucleophilic base like LDA or LiHMDS at $-78\text{ }^{\circ}\text{C}$. [6][7]
- **Poor Electrophile Reactivity:** The choice of alkyl halide is critical. Reactivity follows the trend: Iodides > Bromides > Tosylates > Chlorides.[4] Using less reactive electrophiles like secondary or tertiary halides can lead to competing elimination reactions.[4]

- **Proton Exchange:** If the enolate is not formed quantitatively, residual starting material can act as a proton source, quenching the enolate.[8] Using a full equivalent of a strong base minimizes this.
- **Product Loss During Work-up:** α -Alkylated proline derivatives can sometimes be water-soluble. Ensure thorough extraction from the aqueous phase, possibly by using a continuous extraction apparatus or by saturating the aqueous layer with NaCl.

Q2: How can I improve the diastereoselectivity of my reaction?

Diastereoselectivity is governed by the steric environment of the proline enolate.

- **N-Protecting Group:** The choice of the N-protecting group can significantly influence the stereochemical outcome.[1] For instance, N-Boc and N-Benzoyl groups can lead to different diastereomeric ratios depending on the electrophile used.[1]
- **Ester Group:** Increasing the steric bulk of the ester group (e.g., using a menthyl ester instead of a methyl ester) can enhance diastereoselectivity.[1]
- **Additives:** Polar, aprotic additives like Hexamethylphosphoramide (HMPA) or 1,3-Dimethyl-3,4,5,6-tetrahydro-2(1H)-pyrimidinone (DMPU) can break up lithium enolate aggregates, increasing reactivity and sometimes altering selectivity.[8][9][10] However, be aware of the toxicity of HMPA.
- **Temperature Control:** Maintaining a low temperature (-78 °C) throughout the deprotonation and alkylation steps is crucial for maximizing selectivity.

Q3: My starting material is never fully consumed, even with excess base and electrophile.

What's wrong?

This often points to an issue with the quality of your reagents or solvent.

- **Wet Solvent:** Tetrahydrofuran (THF) is hygroscopic. Even trace amounts of water will quench the strong base and the enolate. Ensure your THF is freshly distilled from a suitable drying agent (e.g., sodium/benzophenone) or is from a recently opened bottle of anhydrous grade solvent.

- **Base Degradation:** Strong bases like LDA can degrade over time, especially if not stored properly. It is often best to prepare LDA fresh before use or titrate it to determine its exact molarity.
- **Impure Starting Material:** Ensure your proline derivative is pure and dry.

Q4: I see multiple spots on my TLC plate after the reaction. What are the likely side products?

- **O-Alkylation:** The enolate has two nucleophilic sites: the α -carbon and the oxygen. While C-alkylation is generally favored, some O-alkylation can occur, especially with more reactive electrophiles or under conditions that favor a more "free" enolate (e.g., with additives like HMPA).[\[11\]](#)[\[12\]](#)
- **Dialkylation:** If the mono-alkylated product still possesses an acidic α -proton and there is excess base and electrophile, a second alkylation can occur. This is more common when using weaker bases that establish an equilibrium.[\[7\]](#)
- **Elimination:** If using a secondary or tertiary alkyl halide, the strong base can promote E2 elimination as a competing pathway.[\[4\]](#)

Section 3: In-Depth Troubleshooting Guide

Deprotonation (Enolate Formation) Stage

Problem: Incomplete or no formation of the enolate, leading to recovery of starting material.

Potential Cause	Troubleshooting Action & Rationale
Insufficiently Strong Base	The pKa of the α -proton of an N-acyl proline ester is typically in the range of 25-30. A base with a conjugate acid pKa significantly higher than this is required for complete deprotonation. [5] Switch to a stronger, non-nucleophilic base.
Base Degradation	LDA and other amide bases are sensitive to moisture and air. Prepare LDA fresh from n-BuLi and diisopropylamine immediately before use, or titrate your commercial solution.[6]
Presence of Protic Impurities	Water or alcohol impurities in the solvent or on glassware will rapidly quench the strong base. Ensure all glassware is oven- or flame-dried and the reaction is run under an inert atmosphere (N_2 or Ar). Use freshly distilled anhydrous solvent.[13]
Incorrect Temperature	Enolate formation with LDA is typically performed at $-78\text{ }^\circ\text{C}$ (a dry ice/acetone bath) to ensure kinetic control and minimize base degradation and side reactions.[3][7]

Table 1: Comparison of Common Bases for Enolate Formation

Base	Typical Solvent	pKa (Conj. Acid)	Advantages	Disadvantages
LDA	THF, Diethyl Ether	~36	Strong, non-nucleophilic, sterically hindered, readily available/prepared. ^{[6][7]}	Thermally unstable above -20 °C; can be difficult to handle.
LiHMDS	THF	~26	More thermally stable than LDA; good for sterically demanding substrates.	Less basic than LDA; may not be sufficient for less acidic protons.
KHMDS	THF	~26	Similar to LiHMDS; potassium enolates can be more reactive.	Can lead to different selectivity compared to lithium enolates.
NaH	THF, DMF	~35	Inexpensive, strong.	Often slow and heterogeneous reaction; solubility issues in THF. ^{[6][14]}

Alkylation (Electrophile Addition) Stage

Problem: Low yield of the desired alkylated product despite successful enolate formation.

Potential Cause	Troubleshooting Action & Rationale
Poor Leaving Group	The reaction is an SN2 displacement. A good leaving group is essential for a fast reaction rate. Use an alkyl iodide or bromide instead of a chloride if the reaction is sluggish.
Sterically Hindered Electrophile	SN2 reactions are sensitive to steric hindrance. [4] Use primary or methyl halides. Avoid secondary and especially tertiary halides, which will favor elimination.
Enolate Aggregation	Lithium enolates exist as aggregates (dimers, tetramers) in THF, which reduces their nucleophilicity.[11] Consider adding a polar cosolvent like HMPA or DMPU (1-2 equivalents) to break up these aggregates and increase reactivity.[8][10] Caution: HMPA is a known carcinogen and should be handled with extreme care.
Competing Elimination	The enolate is a strong base. If the electrophile has β -hydrogens, E2 elimination can compete with SN2 substitution. This is exacerbated by sterically hindered electrophiles and higher temperatures. Maintain low temperatures during addition.

Section 4: Validated Experimental Protocol

General Procedure for the α -Alkylation of N-Boc-L-proline methyl ester:

- Glassware & Atmosphere: All glassware must be rigorously dried in an oven (120 °C) overnight and assembled hot under a positive pressure of dry nitrogen or argon.
- Reagent Preparation:
 - In a flame-dried, three-necked flask equipped with a magnetic stirrer, thermometer, and nitrogen inlet, add anhydrous THF (0.2 M relative to the substrate). Cool the flask to -78

°C using a dry ice/acetone bath.

- Add diisopropylamine (1.1 equivalents) via syringe.
- Slowly add n-butyllithium (1.05 equivalents, typically 1.6 M or 2.5 M in hexanes) dropwise, keeping the internal temperature below -70 °C.
- Stir the resulting LDA solution at -78 °C for 30 minutes.
- Enolate Formation:
 - In a separate flame-dried flask, dissolve N-Boc-L-proline methyl ester (1.0 equivalent) in anhydrous THF.
 - Add the substrate solution dropwise via cannula or syringe to the freshly prepared LDA solution at -78 °C over 20-30 minutes.
 - Stir the resulting pale yellow enolate solution at -78 °C for 1 hour.
- Alkylation:
 - Add the alkyl halide (1.2-1.5 equivalents), either neat or as a solution in THF, dropwise to the enolate solution at -78 °C.
 - Allow the reaction to stir at -78 °C for 2-4 hours, or until TLC analysis indicates consumption of the starting material. The reaction may be allowed to slowly warm to a higher temperature (e.g., -40 °C or 0 °C) if the electrophile is unreactive, but this may compromise diastereoselectivity.
- Work-up and Purification:
 - Quench the reaction at -78 °C by the slow addition of a saturated aqueous solution of ammonium chloride (NH₄Cl).
 - Allow the mixture to warm to room temperature. Transfer to a separatory funnel and dilute with ethyl acetate or diethyl ether.
 - Wash the organic layer sequentially with water and brine.

- Dry the organic layer over anhydrous sodium sulfate (Na_2SO_4), filter, and concentrate under reduced pressure.
- Purify the crude product by flash column chromatography on silica gel to afford the pure α -alkylated proline derivative.[\[15\]](#)

Section 5: Troubleshooting Workflow

This flowchart provides a logical path for diagnosing and solving common issues in your α -alkylation experiments.

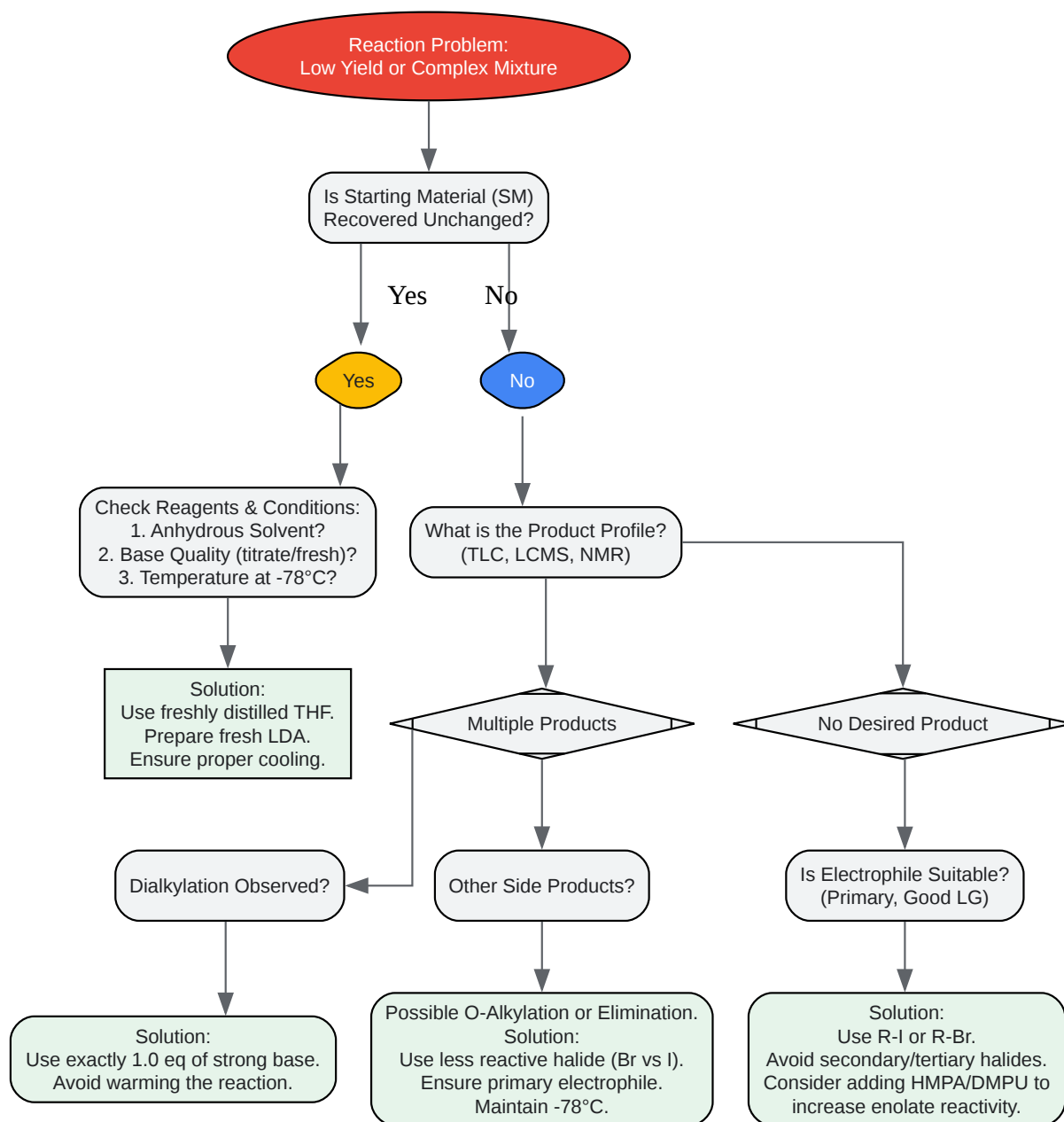

[Click to download full resolution via product page](#)

Caption: A workflow for troubleshooting α -alkylation reactions.

References

- Regioselectivity and Stereoselectivity in the Alkylation of Enolates. (n.d.). quimicaorganica.org. Retrieved from [\[Link\]](#)
- D'hooghe, M., & De Kimpe, N. (2008). Stereoselective Synthesis of Quaternary Proline Analogues. PMC - NIH. Retrieved from [\[Link\]](#)
- Suzuki, M., Koyama, H., & Noyori, R. (2004). Effects of HMPA on the Structure and Reactivity of the Lithium Enolate of Cyclopentanone in THF: The Dimer is Responsible for Alkylation and Proton Exchange Reactions. ResearchGate. Retrieved from [\[Link\]](#)
- Reich, H. J., Sikorski, W. H., & Thompson, J. L. (2004). The Regioselectivity of Addition of Organolithium Reagents to Enones and Enals: The Role of HMPA. ResearchGate. Retrieved from [\[Link\]](#)
- Wikipedia contributors. (n.d.). Enolate. Wikipedia. Retrieved from [\[Link\]](#)
- Bordwell, F. G., & Fried, H. E. (1991). Aggregation and reactivity of the cesium enolate of 6-phenyl-alpha-tetralone: comparison with the lithium enolate. PubMed. Retrieved from [\[Link\]](#)
- LibreTexts. (2019, June 5). 21.4: Enolates. Chemistry LibreTexts. Retrieved from [\[Link\]](#)
- Patsnap. (2025, April 16). Enolates Formation and Reactions: Aldol, Alkylation, and More. Patsnap Eureka. Retrieved from [\[Link\]](#)
- LibreTexts. (2023, January 22). Synthesis of Enols and Enolates. Chemistry LibreTexts. Retrieved from [\[Link\]](#)
- Chad's Prep. (2018, September 21). 21.4a Alpha Alkylation. YouTube. Retrieved from [\[Link\]](#)
- Neuman, R. C. (n.d.). 18: Reactions of Enolate Ions and Enols. Chemistry LibreTexts. Retrieved from [\[Link\]](#)
- Reddit User. (2022, July 25). Bases to promote enolate formation. r/Chempros - Reddit. Retrieved from [\[Link\]](#)

- The Organic Chemistry Tutor. (2014, April 13). Alpha Alkylation Esters. YouTube. Retrieved from [\[Link\]](#)
- Gimalova, F. A., et al. (2022). Diastereoselective Synthesis of Highly Functionalized Proline Derivatives. MDPI. Retrieved from [\[Link\]](#)
- Wikipedia contributors. (n.d.). Proline-catalyzed aldol reactions. Wikipedia. Retrieved from [\[Link\]](#)
- Galland, M., et al. (2022). N-Terminal Selective C–H Azidation of Proline-Containing Peptides: a Platform for Late-Stage Diversification. PMC. Retrieved from [\[Link\]](#)
- Pearson Education. (n.d.). Overview of Alpha-Alkylations and Acylations. Pearson. Retrieved from [\[Link\]](#)
- Martínez-Castañeda, A., et al. (2012). Switching Diastereoselectivity in Proline-Catalyzed Aldol Reactions. Sci-Hub. Retrieved from [\[Link\]](#)
- List, B., et al. (2000). New mechanistic studies on the proline-catalyzed aldol reaction. PNAS. Retrieved from [\[Link\]](#)
- Various Authors. (n.d.). Proline-Catalyzed Asymmetric Reactions. ResearchGate. Retrieved from [\[Link\]](#)
- University of Washington Proteomics Resource. (2011, October 4). Protein Reduction, Alkylation, Digestion. University of Washington. Retrieved from [\[Link\]](#)
- SU960163A1 - Process for purifying proline. (n.d.). Google Patents.
- Murar, C. E., et al. (2017). Improved synthesis of (S)-N-Boc-5-oxaproline for protein synthesis with the α -ketoacid-hydroxylamine (KAHA) ligation. ScienceDirect. Retrieved from [\[Link\]](#)
- Chad's Prep. (2021, April 20). Organic Chemistry - 21.4 Alpha Alkylation. YouTube. Retrieved from [\[Link\]](#)
- Reddit User. (2023, October 11). troubleshooting proline catalyzed methylation/hydroxylation. r/Chempros - Reddit. Retrieved from [\[Link\]](#)

- Farmer, S. (2023, January 22). Alpha Alkylation. Chemistry LibreTexts. Retrieved from [\[Link\]](#)
- Mitchell, T. A., et al. (2012). An analysis of the complementary stereoselective alkylations of imidazolidinone derivatives toward α -quaternary proline-based amino amides. PMC. Retrieved from [\[Link\]](#)
- Organic Chemistry Portal. (2007, March 25). Proline Derivatives in Organic Synthesis. Organic Chemistry Portal. Retrieved from [\[Link\]](#)
- Murar, C. E., et al. (2018). Preparation of (S)-N-Boc-5-oxaproline. Organic Syntheses. Retrieved from [\[Link\]](#)
- AAPPTec. (n.d.). Technical Bulletins & General Procedures. AAPPTec. Retrieved from [\[Link\]](#)
- Balaraman, K., et al. (2018). Direct Catalytic N-Alkylation of α -Amino Acid Esters and Amides Using Alcohols with High Retention of Stereochemistry. Wiley Online Library. Retrieved from [\[Link\]](#)
- G-Biosciences. (n.d.). FOCUS™ Protein Reduction-Alkylation. G-Biosciences. Retrieved from [\[Link\]](#)
- Oh, J., et al. (2019). Recyclable and Stable α -Methylproline-Derived Chiral Ligands for the Chemical Dynamic Kinetic Resolution of free C,N-Unprotected α -Amino Acids. PMC. Retrieved from [\[Link\]](#)
- Chamoin, S., et al. (2005). Automated Parallel Synthesis of N-Alkylated- α -Amino Methyl Esters in Gram Quantities. CHIMIA. Retrieved from [\[Link\]](#)

Need Custom Synthesis?

BenchChem offers custom synthesis for rare earth carbides and specific isotopic labeling.

Email: info@benchchem.com or [Request Quote Online](#).

Sources

- 1. Stereoselective Synthesis of Quaternary Proline Analogues - PMC [[pmc.ncbi.nlm.nih.gov](https://pubmed.ncbi.nlm.nih.gov)]

- [2. Proline Derivatives and Analogs \[sigmaaldrich.com\]](#)
- [3. youtube.com \[youtube.com\]](#)
- [4. chem.libretexts.org \[chem.libretexts.org\]](#)
- [5. chem.libretexts.org \[chem.libretexts.org\]](#)
- [6. chem.libretexts.org \[chem.libretexts.org\]](#)
- [7. Enolates Formation and Reactions: Aldol, Alkylation, and More \[eureka.patsnap.com\]](#)
- [8. Regioselectivity and Stereoselectivity in the Alkylation of Enolates \[quimicaorganica.org\]](#)
- [9. researchgate.net \[researchgate.net\]](#)
- [10. researchgate.net \[researchgate.net\]](#)
- [11. Enolate - Wikipedia \[en.wikipedia.org\]](#)
- [12. Aggregation and reactivity of the cesium enolate of 6-phenyl-alpha-tetralone: comparison with the lithium enolate - PubMed \[pubmed.ncbi.nlm.nih.gov\]](#)
- [13. people.chem.ucsb.edu \[people.chem.ucsb.edu\]](#)
- [14. reddit.com \[reddit.com\]](#)
- [15. mdpi.com \[mdpi.com\]](#)
- To cite this document: BenchChem. [Technical Support Center: Optimizing Yield in the α -Alkylation of Proline Derivatives]. BenchChem, [2026]. [Online PDF]. Available at: [<https://www.benchchem.com/product/b2783374/docs#technical-support-center-optimizing-yield-in-the-alkylation-of-proline-derivatives>]

Disclaimer & Data Validity:

The information provided in this document is for Research Use Only (RUO) and is strictly not intended for diagnostic or therapeutic procedures. While BenchChem strives to provide accurate protocols, we make no warranties, express or implied, regarding the fitness of this product for every specific experimental setup.

Technical Support: The protocols provided are for reference purposes. Unsure if this reagent suits your experiment?

Need Industrial/Bulk Grade? [Request Custom Synthesis Quote](#)

BenchChem

Our mission is to be the trusted global source of essential and advanced chemicals, empowering scientists and researchers to drive progress in science and industry.

Contact

Address: 3281 E Guasti Rd

Ontario, CA 91761, United States

Phone: (601) 213-4426

Email: info@benchchem.com

[Contact our Ph.D. Support Team for a compatibility check](#)