

Application Note: Strategic N-Protection of 1H-Pyrazoles in Complex Heterocyclic Synthesis

Author: BenchChem Technical Support Team. **Date:** April 2026

Compound of Interest

Compound Name:	3-bromo-4-(trifluoromethyl)-1H-pyrazole
CAS No.:	1936710-01-8
Cat. No.:	B2781726

[Get Quote](#)

Target Audience: Researchers, Scientists, and Drug Development Professionals
Content Type: Advanced Application Note & Experimental Protocols

Executive Summary & Strategic Context

The 1H-pyrazole core is a privileged heterocyclic scaffold ubiquitous in medicinal chemistry, agrochemicals, and materials science[1]. However, the intrinsic acidity of the pyrazole N-H proton (pKa ~14.2) presents a significant synthetic liability. If left unprotected, this proton frequently interferes with downstream transformations—most notably palladium-catalyzed cross-couplings (e.g., Suzuki-Miyaura, Heck-Mizoroki) and C-H activation—leading to catalyst deactivation, poor yields, and complex byproduct mixtures[2].

Furthermore, unsymmetrically substituted pyrazoles present a classic regioselectivity challenge: N-alkylation or N-acylation typically yields an inseparable thermodynamic mixture of N1 and N2 isomers[2]. As a Senior Application Scientist, I emphasize that the selection of an N-protecting group (PG) is not merely a defensive measure; it is a strategic maneuver that dictates the regiochemical outcome and overall efficiency of the synthetic route.

Mechanistic Insights: Selecting the Optimal Protecting Group

The choice of protecting group must be governed by the specific steric and electronic demands of your target molecule, as well as the conditions of subsequent functionalization steps.

The SEM Group and the "SEM Switch"

The 2-(trimethylsilyl)ethoxymethyl (SEM) group is the gold standard for complex pyrazole synthesis. It is highly stable to strong bases, nucleophiles, and organometallic reagents[2]. Crucially, the SEM group enables a unique "SEM switch" mechanism. During palladium-catalyzed C-H arylation, the SEM group can transpose from one nitrogen to the other in a single step. This transposition transforms a historically unreactive C-3 position into a highly reactive C-5 position, allowing for the sequential, regioselective synthesis of complex triarylpyrazoles from a single starting material[3].

THP and Green Chemistry

The tetrahydropyranyl (THP) group is an excellent choice for masking the N-H proton while allowing selective lithiation at the C-5 position[4]. Recent methodological advances have enabled a green, solvent-free, and catalyst-free THP protection protocol that yields quantitative results, bypassing the harsh acidic catalysts traditionally required and minimizing chemical waste[5].

Boc and Trityl Groups

The tert-butyloxycarbonyl (Boc) group can be applied under mild, green conditions (e.g., using PEG-400 and DMAP)[6]. However, its reactivity is often underrated; it can be prone to premature cleavage under strongly nucleophilic conditions. Conversely, the Trityl (triphenylmethyl) group provides massive steric bulk, which is highly effective at forcing regioselective protection at the less hindered nitrogen of unsymmetrical pyrazoles[1].

Quantitative Data: Protecting Group Comparison

The following table summarizes the operational parameters for the most common pyrazole protecting groups to guide your strategic planning.

Protecting Group	Reagents	Deprotection Conditions	Stability Profile	Key Strategic Advantage
SEM	SEM-Cl, NaH, THF	TBAF (THF) or HCl (EtOH)	Highly stable to bases, organometallics, and oxidants.	Enables "SEM switch" for sequential C-H arylation[3].
THP	DHP, neat (heat)	Aqueous HCl	Stable to strong bases and hydrides. Acid-labile.	Allows solvent-free green protection; directs C5-lithiation[4][5].
Boc	Boc ₂ O, DMAP, DIPEA	TFA or HCl (Dioxane)	Stable to mild nucleophiles. Base-labile in some contexts.	Mild protection conditions; PEG-400 compatible[6].
Trityl	Tr-Cl, Et ₃ N, DCM	TFA (DCM)	Stable to nucleophiles and bases. Acid-labile.	Massive steric bulk forces high regioselectivity[1].

Process Visualizations

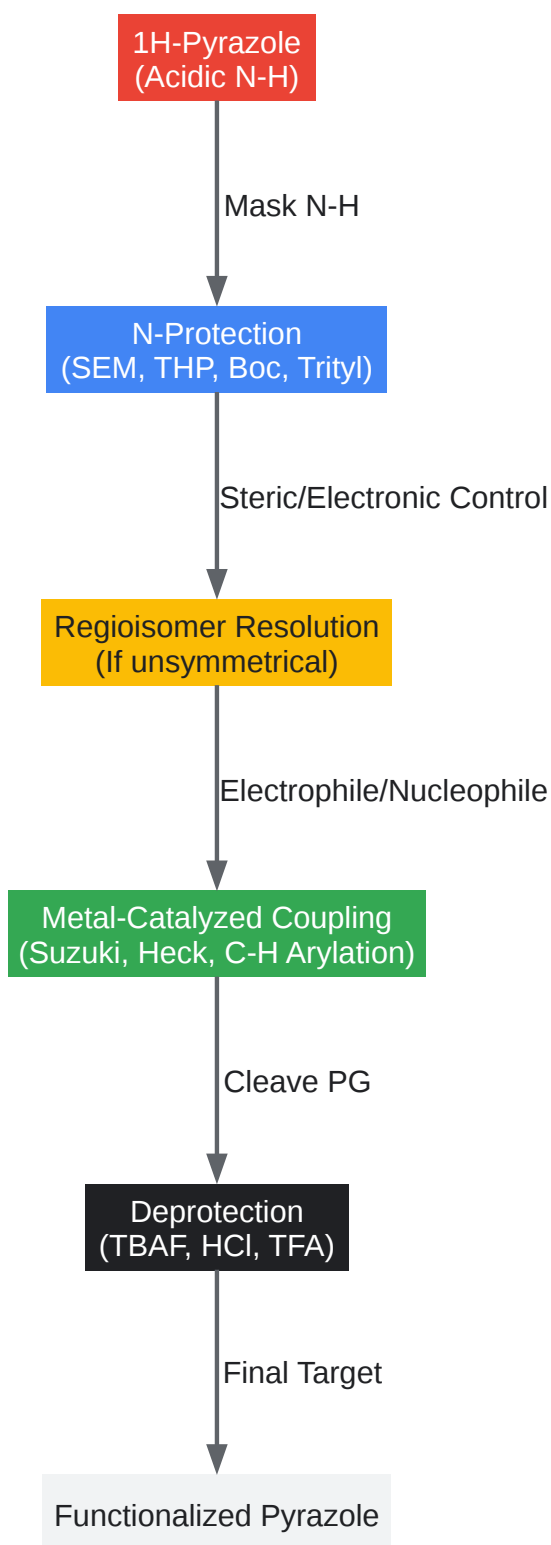

[Click to download full resolution via product page](#)

Figure 1: General workflow for N-protected pyrazole functionalization.

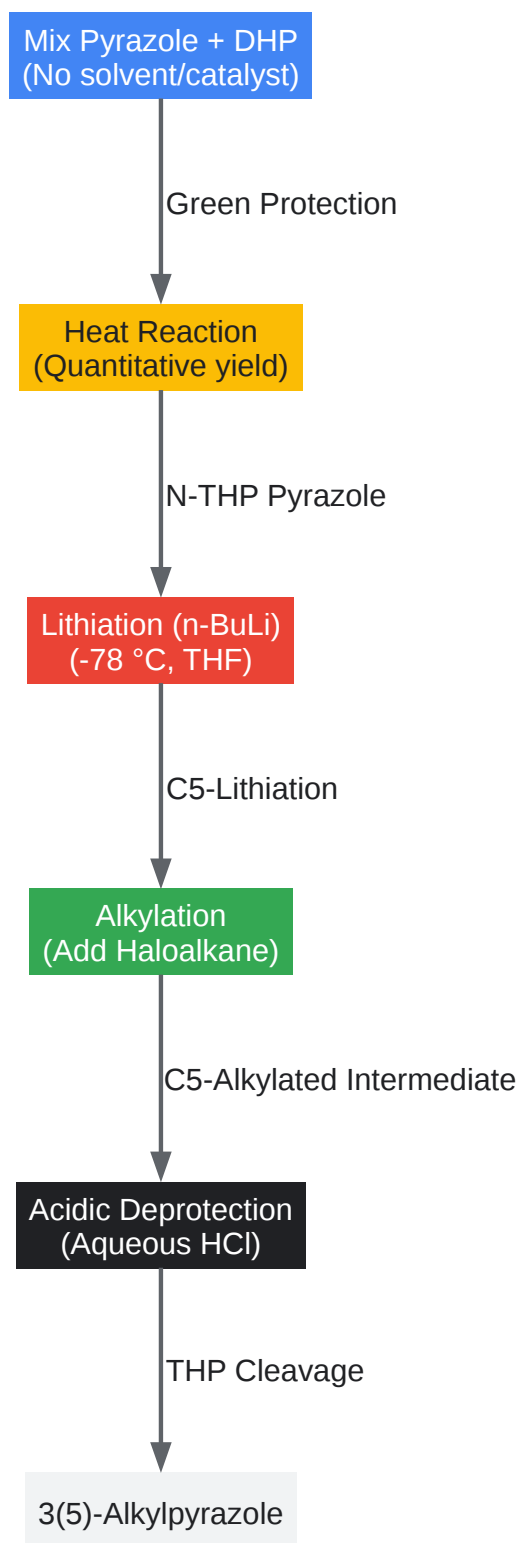

[Click to download full resolution via product page](#)

Figure 2: Solvent-free THP protection and subsequent one-pot alkylation.

Experimental Workflows & Self-Validating Protocols

The following protocols are designed as self-validating systems, incorporating specific causality explanations and in-process checks to ensure scientific integrity.

Protocol A: SEM Protection of 1H-Pyrazole

Causality Rationale: Sodium hydride (NaH) is employed as a strong, non-nucleophilic base. It irreversibly deprotonates the pyrazole N-H, driving the equilibrium forward by releasing hydrogen gas. This ensures the pyrazole nitrogen is sufficiently nucleophilic to attack the SEM-Cl electrophile without reversible side reactions[2].

- **Preparation:** Dissolve the 1H-pyrazole (1.0 eq) in anhydrous THF (0.2 M concentration) under an inert argon atmosphere.
- **Deprotonation:** Cool the solution to 0 °C using an ice bath. Carefully add NaH (60% dispersion in mineral oil, 1.2 eq) portion-wise.
 - **Self-Validation Check:** The addition of NaH must result in observable hydrogen gas evolution. Stir for 30 minutes at 0 °C; the cessation of bubbling indicates complete deprotonation[2].
- **Alkylation:** Add SEM-Cl (1.1 eq) dropwise to the cold mixture. Allow the reaction to slowly warm to room temperature and stir for 2-4 hours.
 - **Self-Validation Check:** Monitor by TLC (Hexanes/EtOAc). The SEM-protected pyrazole will exhibit a significantly higher R_f value compared to the highly polar, hydrogen-bonding unprotected starting material[2].
- **Workup:** Quench carefully with cold water. Extract the aqueous layer with Ethyl Acetate (3x). Wash the combined organic layers with brine, dry over anhydrous Na₂SO₄, and concentrate under reduced pressure. Purify via silica gel chromatography.

Protocol B: Solvent-Free THP Protection & One-Pot Alkylation

Causality Rationale: Heating pyrazole with 3,4-dihydro-2H-pyran (DHP) neat drives quantitative conversion via thermal isomerization without the need for acidic catalysts, preventing waste[5]. The installed THP group then acts as an internal directing group for regioselective C5-lithiation[4].

- Green Protection: Mix 1H-pyrazole (1.0 eq) and DHP (1.5 eq) in a round-bottom flask without solvent. Heat the mixture to 80 °C for 4 hours.
 - Self-Validation Check: The heterogeneous mixture should transition to a homogeneous liquid. Quantitative conversion can be confirmed by the disappearance of the broad N-H stretch ($\sim 3100\text{-}3200\text{ cm}^{-1}$) in the IR spectrum[1][5].
- Lithiation: Cool the flask to room temperature, dissolve the intermediate in anhydrous THF, and cool to -78 °C. Add n-BuLi (1.1 eq) dropwise. Stir for 1 hour.
 - Self-Validation Check: Quenching a small reaction aliquot with D₂O and analyzing via ¹H NMR should reveal >95% deuterium incorporation exclusively at the C5 position[4].
- Alkylation: Add the desired haloalkane (1.2 eq) dropwise at -78 °C. Allow the mixture to warm to room temperature overnight.
- Deprotection: Add 2M aqueous HCl directly to the reaction pot and stir for 2 hours to cleave the THP group. Neutralize, extract, and purify to isolate the 3(5)-alkylpyrazole[4].

Protocol C: Fluoride-Mediated SEM Deprotection

Causality Rationale: The thermodynamic driving force for this cleavage is the exceptionally strong silicon-fluorine bond ($\sim 582\text{ kJ/mol}$). Tetrabutylammonium fluoride (TBAF) provides a soluble fluoride source that selectively attacks the silicon atom of the SEM group, initiating fragmentation and releasing the free pyrazole under mild, non-acidic conditions[2].

- Dissolution: Dissolve the SEM-protected pyrazole (1.0 eq) in anhydrous THF.
- Reagent Addition: Add a solution of TBAF in THF (1.0 M, 1.5-2.0 eq) at room temperature.
- Reaction Execution: Heat the mixture gently (40-50 °C) if steric hindrance slows the reaction[2].

- Self-Validation Check: LC-MS monitoring is ideal here; the mass spectrum will show the loss of the SEM group (M - 130 Da) and the appearance of the free pyrazole mass[2].
- Workup: Dilute with water, extract with ethyl acetate, dry, and purify.

References

- BenchChem Technical Support Team. "A Senior Application Scientist's Guide to N-Protection of Pyrazoles: Unveiling the Superiority of the SEM Group over Boc and THP." BenchChem.
- BenchChem Technical Support Team. "Green Synthesis Protocol for Tetrahydropyranyl (THP) Protection of Pyrazole." BenchChem.
- "C-H Bonds as Ubiquitous Functionality: A General Approach to Complex Arylated Pyrazoles via Sequential Regioselective C-arylation and N-alkylation Enabled by SEM-group Transposition." PMC - NIH.
- "Green protection of pyrazole, thermal isomerization and deprotection of tetrahydropyranylpurazoles, and high-yield, one-pot synthesis of 3(5)-alkylpyrazoles." RSC Publishing.
- "Green approach toward protection of secondary amine in pyrazole nucleus by PEG-400 and Boc catalyst." Journal of Applied Pharmaceutical Science.
- "3-Bromo-1H-pyrazole|Building Block for R&D." Benchchem.

Need Custom Synthesis?

BenchChem offers custom synthesis for rare earth carbides and specific isotopic labeling.

Email: info@benchchem.com or [Request Quote Online](#).

Sources

1. 3-Bromo-1H-pyrazole|Building Block for R&D [[benchchem.com](https://www.benchchem.com)]
2. 1-((2-(Trimethylsilyl)ethoxy)methyl)-1H-pyrazole | 133560-57-3 | Benchchem [[benchchem.com](https://www.benchchem.com)]
3. [pmc.ncbi.nlm.nih.gov](https://pubmed.ncbi.nlm.nih.gov/) [[pmc.ncbi.nlm.nih.gov](https://pubmed.ncbi.nlm.nih.gov/)]
4. 1-(2-Tetrahydropyranyl)-1H-pyrazole | 449758-17-2 | Benchchem [[benchchem.com](https://www.benchchem.com)]
5. Green protection of pyrazole, thermal isomerization and deprotection of tetrahydropyranylpurazoles, and high-yield, one-pot synthesis of 3(5)-alkylpyrazoles - RSC Advances (RSC Publishing) [pubs.rsc.org]

- [6. japsonline.com \[japsonline.com\]](https://www.japsonline.com)
- To cite this document: BenchChem. [Application Note: Strategic N-Protection of 1H-Pyrazoles in Complex Heterocyclic Synthesis]. BenchChem, [2026]. [Online PDF]. Available at: [<https://www.benchchem.com/product/b2781726/docs#application-note-strategic-n-protection-of-1h-pyrazoles-in-complex-heterocyclic-synthesis>]

Disclaimer & Data Validity:

The information provided in this document is for Research Use Only (RUO) and is strictly not intended for diagnostic or therapeutic procedures. While BenchChem strives to provide accurate protocols, we make no warranties, express or implied, regarding the fitness of this product for every specific experimental setup.

Technical Support: The protocols provided are for reference purposes. Unsure if this reagent suits your experiment?

Need Industrial/Bulk Grade? [Request Custom Synthesis Quote](#)

BenchChem

Our mission is to be the trusted global source of essential and advanced chemicals, empowering scientists and researchers to drive progress in science and industry.

Contact

Address: 3281 E Guasti Rd
Ontario, CA 91761, United States
Phone: (601) 213-4426
Email: info@benchchem.com

[Contact our Ph.D. Support Team for a compatibility check](#)