

# A Comparative Guide to the Regioselectivity of Pyrazole Iodination Reagents

**Author:** BenchChem Technical Support Team. **Date:** April 2026

## Compound of Interest

Compound Name: 4-iodo-1-(4-methoxyphenyl)pyrazole  
CAS No.: 1260761-37-2  
Cat. No.: B2776118

[Get Quote](#)

## Introduction: The Significance of Iodinated Pyrazoles

Iodinated pyrazoles are pivotal building blocks in modern chemical synthesis, particularly within the pharmaceutical and agrochemical industries.<sup>[1][2]</sup> The introduction of an iodine atom onto the pyrazole scaffold provides a versatile handle for a variety of synthetic transformations, most notably in cross-coupling reactions such as Suzuki-Miyaura and Sonogashira reactions.<sup>[3][4]</sup> These reactions enable the construction of complex molecular architectures, making iodinated pyrazoles highly valuable intermediates in drug discovery and development.<sup>[1][2]</sup> However, the regioselective synthesis of iodinated pyrazoles can be challenging, as the pyrazole ring possesses multiple reactive sites. This guide provides a comparative analysis of common iodination reagents, with a focus on their regioselectivity, supported by experimental data to aid researchers in selecting the optimal method for their specific synthetic needs.

## Factors Governing Regioselectivity in Pyrazole Iodination

The regioselectivity of electrophilic substitution on the pyrazole ring is primarily dictated by a combination of electronic and steric factors.[5]

- **Electronic Effects:** The pyrazole ring is an electron-rich aromatic system. Electrophilic substitution, such as iodination, generally occurs at the C4 position, which is the most electron-rich and sterically accessible position.[5][6] The presence of electron-donating groups (EDGs) on the pyrazole ring can enhance the rate of electrophilic substitution but may also lead to over-iodination. Conversely, electron-withdrawing groups (EWGs) deactivate the ring, making iodination more challenging and often requiring more potent iodinating agents or harsher reaction conditions.[5]
- **Steric Effects:** The steric environment around the pyrazole ring plays a crucial role in directing the incoming electrophile. Bulky substituents at the N1 or C5 positions can hinder the approach of the iodinating reagent to the C5 position, thereby favoring substitution at the C4 position.[5]
- **Reaction Conditions:** The choice of solvent, temperature, and the specific iodinating system can significantly influence the regioselectivity of the reaction.[5] Some methods may operate under kinetic control, while others may favor the thermodynamically more stable product.

## Comparative Analysis of Common Iodination Reagents

A variety of reagents and methods have been developed for the iodination of pyrazoles. The choice of the most suitable method depends on the desired regioselectivity, the nature of the substituents on the pyrazole ring, and considerations for green chemistry.

### Iodine with an Oxidant

The use of molecular iodine ( $I_2$ ) in the presence of an oxidizing agent is a common and effective strategy for the regioselective iodination of pyrazoles at the C4 position.[5] The oxidant generates a more electrophilic iodine species in situ, facilitating the reaction.

- **Iodine/Hydrogen Peroxide ( $I_2/H_2O_2$ ):** This system is considered a "green" and practical method as it uses water as a solvent and generates water as the only byproduct.[1][5][7] It is

effective for a range of substituted pyrazoles, affording good to excellent yields of 4-iodopyrazoles.<sup>[1][7]</sup>

- Iodine/Ceric Ammonium Nitrate (I<sub>2</sub>/CAN): This method is particularly effective for the regioselective C4-iodination of various pyrazole derivatives, including those with deactivating groups like trifluoromethyl (-CF<sub>3</sub>).<sup>[1][3][4][8]</sup> The reaction is typically carried out in acetonitrile at elevated temperatures.<sup>[3][5]</sup> However, with electron-rich N-aryl substituents, CAN can sometimes lead to undesired side reactions like nitration.<sup>[3][4]</sup>

## N-Iodosuccinimide (NIS)

N-Iodosuccinimide (NIS) is a mild and efficient iodinating agent that is often used for the C4-iodination of pyrazoles.<sup>[1][5]</sup> Its reactivity can be enhanced by the addition of an acid catalyst, such as trifluoroacetic acid (TFA) or sulfuric acid, making it suitable for less reactive, electron-deficient pyrazoles.<sup>[3][5][9]</sup> The use of NIS in acidic media is an efficient method for the iodination of deactivated pyrazole systems.<sup>[1]</sup>

## Iodine Monochloride (ICl)

Iodine monochloride (ICl) is a potent electrophilic iodinating agent that can be used for the regioselective C4-iodination of pyrazoles.<sup>[1][10]</sup> It is particularly effective for the dehydration and subsequent iodination of 1-acyl-5-hydroxy-4,5-dihydro-1H-pyrazoles to yield 1-acyl-4-iodo-1H-pyrazoles.<sup>[10][11]</sup> The addition of a base, such as lithium carbonate (Li<sub>2</sub>CO<sub>3</sub>), is often necessary to neutralize the HCl formed during the reaction.<sup>[1][10]</sup>

## n-Butyllithium/Iodine (n-BuLi/I<sub>2</sub>)

In contrast to the electrophilic substitution methods that predominantly yield 4-iodopyrazoles, the use of n-butyllithium followed by quenching with molecular iodine provides a highly regioselective route to 5-iodopyrazoles.<sup>[1][3][4][8]</sup> This method proceeds via deprotonation at the C5 position to form a lithium pyrazolide intermediate, which is then trapped by iodine.<sup>[3][4]</sup><sup>[8]</sup> This approach offers exclusive synthesis of 5-iodo pyrazole derivatives.<sup>[3][4]</sup>

## Data Summary

Reagent/System	Typical Conditions	Regioselectivity	Typical Yield (%)	Notes
I <sub>2</sub> /H <sub>2</sub> O <sub>2</sub>	Water, Room Temp.[1][5]	C4[1]	63 - 100[1]	Green and practical method. [1][5][7]
I <sub>2</sub> /CAN	Acetonitrile, Reflux[1][3]	C4[1][3][4]	Good to Excellent[1][3]	Effective for deactivated pyrazoles.[1][3] Potential for side reactions with electron-rich arenes.[3][4]
NIS/Acid	Various solvents, Room Temp. to 80 °C[1][3][5]	C4[1]	Good[1]	Suitable for deactivated pyrazoles when used with an acid catalyst.[1][5]
ICl/Base	Dichloromethane, Room Temp.[1][10]	C4[1]	Up to 95[1][10]	Effective for 1-acyl-4-iodo-3,5-disubstituted pyrazoles.[1][10] Base is crucial to neutralize HCl.[1][10]
n-BuLi/I <sub>2</sub>	THF, -78 °C to Room Temp.[1][3]	C5[1][3][4]	65 - 89[1][3]	Exclusive synthesis of 5-iodo derivatives. [3][4]

## Mechanistic Insights

The regioselectivity of pyrazole iodination can be understood by considering the underlying reaction mechanisms.

## Electrophilic Substitution at C4

The iodination of pyrazoles with reagents like I<sub>2</sub>/oxidant, NIS, and ICl proceeds through a classical electrophilic aromatic substitution mechanism. The pyrazole ring acts as a nucleophile, attacking the electrophilic iodine species. The C4 position is the most nucleophilic and sterically accessible, leading to the preferential formation of the 4-iodo product.

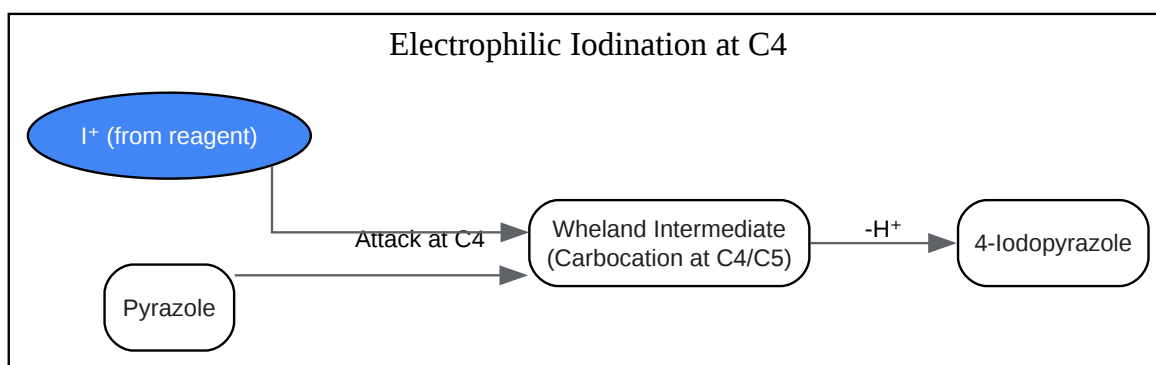

[Click to download full resolution via product page](#)

Caption: Generalized mechanism for electrophilic iodination at the C4 position of the pyrazole ring.

## Directed Lithiation and Iodination at C5

The synthesis of 5-iodopyrazoles via the n-BuLi/I<sub>2</sub> method follows a different pathway. The strong base, n-butyllithium, selectively deprotonates the most acidic proton on the pyrazole ring, which is at the C5 position. This generates a highly nucleophilic lithium pyrazolide intermediate, which then reacts with molecular iodine to afford the 5-iodo product.

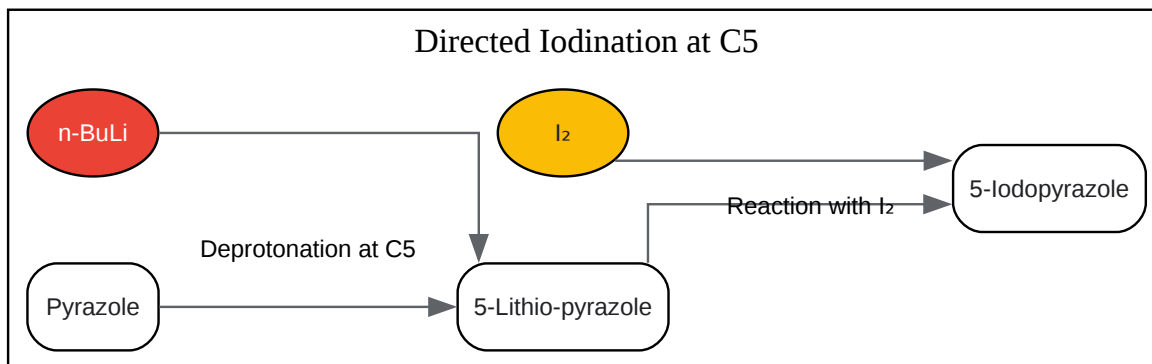

[Click to download full resolution via product page](#)

Caption: Mechanism for the synthesis of 5-iodopyrazoles via directed lithiation.

## Experimental Protocols

### General Procedure for C4-Iodination using I<sub>2</sub>/CAN[3]

- To a solution of the 1-aryl-3-trifluoromethylpyrazole (1.0 mmol) in acetonitrile (6 mL), add ceric ammonium nitrate (CAN) (1.1 mmol) and elemental iodine (1.3 mmol).
- Reflux the reaction mixture overnight.
- Remove the solvent under reduced pressure.
- Dissolve the residue in dichloromethane (15 mL) and wash with saturated aqueous Na<sub>2</sub>S<sub>2</sub>O<sub>3</sub> (5 mL) and then with water (10 mL).
- Dry the organic layer over Na<sub>2</sub>SO<sub>4</sub>, filter, and concentrate in vacuo.
- Purify the crude product by column chromatography on silica gel to afford the 4-iodopyrazole.

### General Procedure for C4-Iodination using NIS/TFA[3][5]

- To a solution of the pyrazole (1.0 mmol) in glacial acetic acid (1 mL), add a solution of N-iodosuccinimide (NIS) (1.5 mmol) in trifluoroacetic acid (TFA) (1 mL).

- Heat the resulting mixture overnight at 80 °C.
- Cool the solution to room temperature, dilute with dichloromethane (60 mL), and wash with saturated aqueous Na<sub>2</sub>S<sub>2</sub>O<sub>3</sub> (2 x 5 mL) and then with saturated aqueous NaHCO<sub>3</sub>.
- Dry the organic layer over anhydrous Na<sub>2</sub>SO<sub>4</sub>, filter, and concentrate under reduced pressure.
- Purify the crude product by column chromatography on silica gel.

## General Procedure for C5-Iodination using n-BuLi/I<sub>2</sub>[3] [4]

- Dissolve the 1-aryl-3-CF<sub>3</sub>-1H-pyrazole (1.0 mmol) in dry THF (5 mL) under an inert atmosphere.
- Cool the solution to -78 °C.
- Add n-butyllithium (1.3 equivalents) dropwise with vigorous stirring and stir for 10 minutes at -78 °C.
- Add a solution of iodine (1.4 equivalents) in dry THF (3 mL).
- Allow the reaction mixture to warm to room temperature.
- Quench the reaction with a saturated aqueous solution of ammonium chloride.
- Extract the mixture with dichloromethane, wash the organic layer with saturated aqueous sodium thiosulfate and then with water.
- Dry the organic layer over anhydrous sodium sulfate, concentrate under reduced pressure, and purify the product by column chromatography.

## Conclusion

The regioselective iodination of pyrazoles is a well-established yet nuanced field, with a variety of reagents available to the synthetic chemist. For the synthesis of 4-iodopyrazoles, electrophilic iodination using I<sub>2</sub>/oxidant systems or NIS/acid offers reliable and high-yielding

routes, with the choice depending on the substrate's electronic properties and desired reaction conditions. For the exclusive synthesis of 5-iodopyrazoles, a directed lithiation approach using n-BuLi followed by iodination is the method of choice. By understanding the interplay of electronic, steric, and mechanistic factors, researchers can confidently select the most appropriate iodination strategy to advance their synthetic endeavors.

## References

- BenchChem. (2025). Synthesis of 4-Iodopyrazole - Technical Support Center.
- BenchChem. (2025). A Comparative Guide to the Iodination of Pyrazoles for Researchers and Drug Development Professionals.
- Yuriy S. Moroz, et al. (2025). Exercise in 1-aryl-3-CF<sub>3</sub>-1H-pyrazoles: regioselective synthesis of 4-/5-iodides and cross-coupling reactions. RSC Advances.
- Arkat USA. (n.d.). Synthesis of substituted-3-iodo-1H-pyrazole derivatives and their further modification under Sonogashira cross-coupling reaction.
- BenchChem. (2025). Navigating the Challenges of Scaling Up 4-Iodopyrazole Reactions: A Technical Support Guide.
- Saito, A., Yoshida, K., & Togo, H. (2022).
- Moroz, Y. S., et al. (2025). Exercise in 1-aryl-3-CF<sub>3</sub>-1H-pyrazoles: regioselective synthesis of 4-/5-iodides and cross-coupling reactions. RSC Publishing.
- Krasnokutskaya, E. A., et al. (2021). Electrooxidation Is a Promising Approach to Functionalization of Pyrazole-Type Compounds. *Molecules*, 26(16), 4785.
- Waldo, J. P., Mehta, S., & Larock, R. C. (2008). Room Temperature ICI-Induced Dehydration/Iodination of 1-Acyl-5-hydroxy-4,5-dihydro-1H-pyrazoles. A Selective Route to Substituted 1-Acyl-4-iodo-1H-pyrazoles. *The Journal of Organic Chemistry*, 73(17), 6666–6670.
- Moroz, Y. S., et al. (2025). Exercise in 1-aryl-3-CF<sub>3</sub>-1H-pyrazoles: regioselective synthesis of 4-/5-iodides and cross-coupling reactions. RSC Advances.
- Organic Chemistry Portal. (n.d.).
- Olah, G. A., et al. (2007). Iodination of deactivated aromatic compounds with N-iodosuccinimide in sulfuric acid. *Arkivoc*, 2007(13), 13-19.
- Waldo, J. P., Mehta, S., & Larock, R. C. (2008). Room Temperature ICI-Induced Dehydration/Iodination of 1-Acyl-5-hydroxy-4,5-dihydro-1H-pyrazoles. A Selective Route to Substituted 1-Acyl-4-iodo-1H-pyrazoles. PMC.
- Guchhait, S. K., et al. (2011). Green iodination of pyrazoles with iodine/hydrogen peroxide in water. *Tetrahedron Letters*, 52(49), 6594-6597.

### Need Custom Synthesis?

BenchChem offers custom synthesis for rare earth carbides and specific isotopic labeling.

Email: [info@benchchem.com](mailto:info@benchchem.com) or [Request Quote Online](#).

## Sources

- [1. pdf.benchchem.com](https://pdf.benchchem.com) [[pdf.benchchem.com](https://pdf.benchchem.com)]
- [2. Iodoarenes synthesis by iodination or substitution](#) [[organic-chemistry.org](https://organic-chemistry.org)]
- [3. Exercise in 1-aryl-3-CF<sub>3</sub>-1H-pyrazoles: regioselective synthesis of 4-/5-iodides and cross-coupling reactions - PMC](#) [[pmc.ncbi.nlm.nih.gov](https://pubmed.ncbi.nlm.nih.gov)]
- [4. pubs.rsc.org](https://pubs.rsc.org) [[pubs.rsc.org](https://pubs.rsc.org)]
- [5. pdf.benchchem.com](https://pdf.benchchem.com) [[pdf.benchchem.com](https://pdf.benchchem.com)]
- [6. arkat-usa.org](https://arkat-usa.org) [[arkat-usa.org](https://arkat-usa.org)]
- [7. researchgate.net](https://researchgate.net) [[researchgate.net](https://researchgate.net)]
- [8. Exercise in 1-aryl-3-CF<sub>3</sub>-1H-pyrazoles: regioselective synthesis of 4-/5-iodides and cross-coupling reactions - RSC Advances \(RSC Publishing\) DOI:10.1039/D5RA01103E](#) [[pubs.rsc.org](https://pubs.rsc.org)]
- [9. researchgate.net](https://researchgate.net) [[researchgate.net](https://researchgate.net)]
- [10. Room Temperature ICl-Induced Dehydration/Iodination of 1-Acyl-5-hydroxy-4,5-dihydro-1H-pyrazoles. A Selective Route to Substituted 1-Acyl-4-iodo-1H-pyrazoles](#) [[organic-chemistry.org](https://organic-chemistry.org)]
- [11. Room Temperature ICl-Induced Dehydration/Iodination of 1-Acyl-5-hydroxy-4,5-dihydro-1H-pyrazoles. A Selective Route to Substituted 1-Acyl-4-iodo-1H-pyrazoles - PMC](#) [[pmc.ncbi.nlm.nih.gov](https://pubmed.ncbi.nlm.nih.gov)]
- To cite this document: BenchChem. [A Comparative Guide to the Regioselectivity of Pyrazole Iodination Reagents]. BenchChem, [2026]. [Online PDF]. Available at: [<https://www.benchchem.com/product/b2776118/docs#a-comparative-guide-to-the-regioselectivity-of-pyrazole-iodination-reagents>]

---

### Disclaimer & Data Validity:

The information provided in this document is for Research Use Only (RUO) and is strictly not intended for diagnostic or therapeutic procedures. While BenchChem strives to provide accurate protocols, we make no warranties, express or implied, regarding the fitness of this product for every specific experimental setup.

**Technical Support:** The protocols provided are for reference purposes. Unsure if this reagent suits your experiment?

**Need Industrial/Bulk Grade?** [Request Custom Synthesis Quote](#)

## BenchChem

Our mission is to be the trusted global source of essential and advanced chemicals, empowering scientists and researchers to drive progress in science and industry.

### Contact

Address: 3281 E Guasti Rd  
Ontario, CA 91761, United States  
Phone: (601) 213-4426  
Email: [info@benchchem.com](mailto:info@benchchem.com)

[Contact our Ph.D. Support Team for a compatibility check](#)