

solution-phase peptide synthesis using Z-D-Lys(boc)-ome

Author: BenchChem Technical Support Team. **Date:** April 2026

Compound of Interest

Compound Name: Z-D-Lys(boc)-ome

CAS No.: 84559-78-4

Cat. No.: B2770620

[Get Quote](#)

Application Note: High-Efficiency Solution-Phase Peptide Synthesis Using Z-D-Lys(Boc)-OMe

Strategic Overview & Rationale

Z-D-Lys(Boc)-OMe (Methyl

-benzyloxycarbonyl-

-tert-butoxycarbonyl-D-lysinate) represents a cornerstone building block in the synthesis of protease-resistant peptidomimetics and antimicrobial peptides (AMPs).

Unlike standard L-amino acids, the incorporation of the D-isomer confers significant enzymatic stability to the final peptide, extending in vivo half-life—a critical attribute for therapeutic development. This guide details the Solution-Phase Synthesis (SPS) handling of this molecule. Unlike Solid-Phase Peptide Synthesis (SPPS), SPS allows for the isolation, characterization, and purification of intermediates, making it the preferred method for scaling up short-to-medium chain peptides (2–10 residues).

The Orthogonal Protection Strategy: This molecule utilizes a "Three-Dimensional" orthogonality:

- -Amine (Z/Cbz): Removed by catalytic hydrogenolysis (). Stable to acid and mild base.
- -Amine (Boc): Removed by strong acid (TFA/HCl). Stable to hydrogenolysis and base.
- C-Terminus (OMe): Removed by saponification (LiOH). Stable to acid and hydrogenolysis.

Chemical Profile & Properties[1][2][3][4][5][6][7]

Property	Specification
Chemical Name	Z-D-Lys(Boc)-OMe
CAS Number	84559-78-4
Molecular Weight	394.47 g/mol
Appearance	White to off-white powder
Solubility	Soluble in MeOH, EtOH, DMF, DCM, EtOAc
Melting Point	63–70 °C
Storage	2–8 °C (Desiccated)

Strategic Protection Map (Visualization)

The following diagram illustrates the orthogonal deprotection pathways, guiding the chemist on which reagent triggers which cleavage without affecting the other groups.

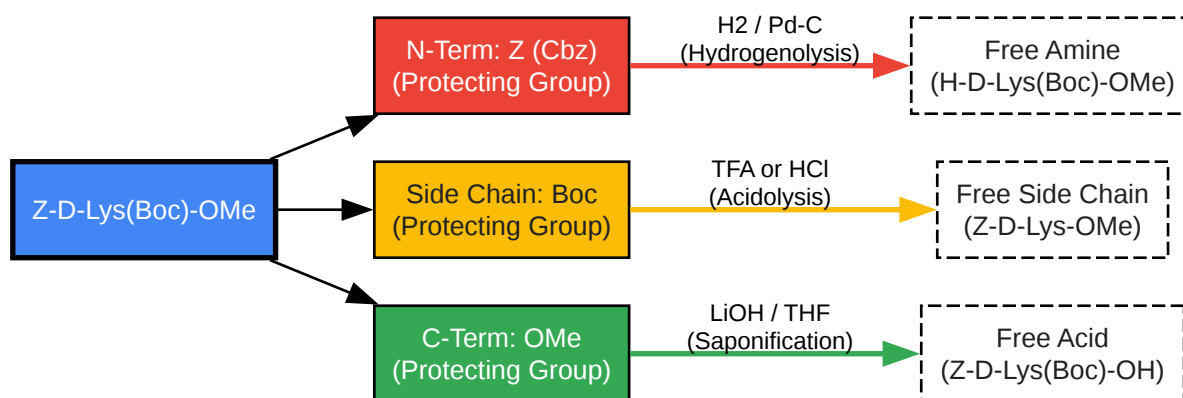

[Click to download full resolution via product page](#)

Figure 1: Orthogonal deprotection vectors for **Z-D-Lys(Boc)-OMe**. Each arm represents a distinct chemical trigger.

Detailed Experimental Protocols

Protocol A: C-Terminal Activation (Saponification)

Objective: Convert the methyl ester (OMe) to a carboxylic acid (OH) to allow coupling to the next amino acid amine.

Expert Insight: Racemization of D-amino acids is a critical risk during base-mediated hydrolysis. We utilize Lithium Hydroxide (LiOH) rather than NaOH or KOH. The lithium cation () is less coordinating and the reaction can proceed at lower temperatures, significantly reducing the rate of -proton abstraction (enolization) which causes racemization.

Reagents:

- **Z-D-Lys(Boc)-OMe** (1.0 eq)
- LiOH
- H
- O (1.5 – 2.0 eq)

- Solvent: THF/Water (3:1 v/v) or MeOH/Water

- 1M HCl or KHSO

solution

Step-by-Step:

- Dissolution: Dissolve 1.0 g (2.53 mmol) of **Z-D-Lys(Boc)-OMe** in 15 mL of THF. Cool the solution to 0 °C in an ice bath.

- Saponification: Dissolve LiOH

H

O (160 mg, 3.8 mmol) in 5 mL of water. Add this dropwise to the peptide solution.

- Reaction: Stir at 0 °C for 30 minutes, then allow to warm to Room Temperature (RT). Monitor by TLC (System: CHCl

/MeOH 9:1). The ester spot (

) should disappear, replaced by a baseline acid spot.

- Workup (Critical):

- Evaporate THF under reduced pressure (keep bath

°C).

- Dilute the remaining aqueous residue with 10 mL water.

- Wash with diethyl ether (

mL) to remove unreacted ester or non-polar impurities. Discard organic layer.

- Acidification: Cool aqueous layer to 0 °C. Carefully acidify to pH 2–3 using 1M KHSO

or 1M HCl. Note: Z-D-Lys(Boc)-OH typically precipitates as a white solid or oil.

- Extraction: Extract the cloudy acidic mixture with Ethyl Acetate (EtOAc) (

mL).

- Drying: Wash combined EtOAc layers with Brine, dry over anhydrous Na

SO

, and concentrate in vacuo.

Protocol B: N-Terminal Deprotection (Hydrogenolysis)

Objective: Remove the Z (Cbz) group to expose the

-amine for coupling to an upstream carboxylic acid.

Expert Insight: The Boc group is stable to catalytic hydrogenation. However, safety is paramount. Dry Pd/C catalysts are pyrophoric. Always wet the catalyst with an inert solvent (toluene or water) or add it under an argon blanket before adding the flammable reaction solvent (MeOH).

Reagents:

- **Z-D-Lys(Boc)-OMe**^[1]
- 10% Pd/C (10 wt% loading)
- Methanol (MeOH)
- Hydrogen gas (balloon)

Step-by-Step:

- Setup: In a round-bottom flask, place **Z-D-Lys(Boc)-OMe** (1.0 g). Dissolve in 20 mL degassed MeOH.
- Catalyst Addition: Under a stream of Nitrogen/Argon, carefully add 100 mg of 10% Pd/C.
- Hydrogenation: Purge the flask with

(vacuum/fill cycle

) using a balloon. Stir vigorously at RT for 2–4 hours.

- Monitoring: TLC should show the disappearance of the UV-active starting material (Z group absorbs UV). The product H-D-Lys(Boc)-OMe is not UV active (visualize with Ninhydrin stain—turns purple/orange).
- Filtration: Filter the mixture through a Celite pad to remove Pd/C. Caution: Do not let the filter cake dry out completely in air.
- Isolation: Concentrate the filtrate to yield H-D-Lys(Boc)-OMe as a viscous oil or solid. Use immediately for coupling to avoid diketopiperazine formation (though less likely with Lys side chain protection).

Protocol C: Solution Phase Coupling (Fragment Assembly)

Objective: Coupling the free acid (from Protocol A) to an amine component (e.g., H-Ala-OBzl).

Expert Insight: To prevent racemization of the D-Lysine during activation, we employ EDC/HOBt. HOBt acts as an auxiliary nucleophile, forming an active ester that is reactive toward amines but less prone to oxazolone formation (the primary pathway for racemization) than the O-acylisourea formed by carbodiimide alone.

Workflow Diagram:

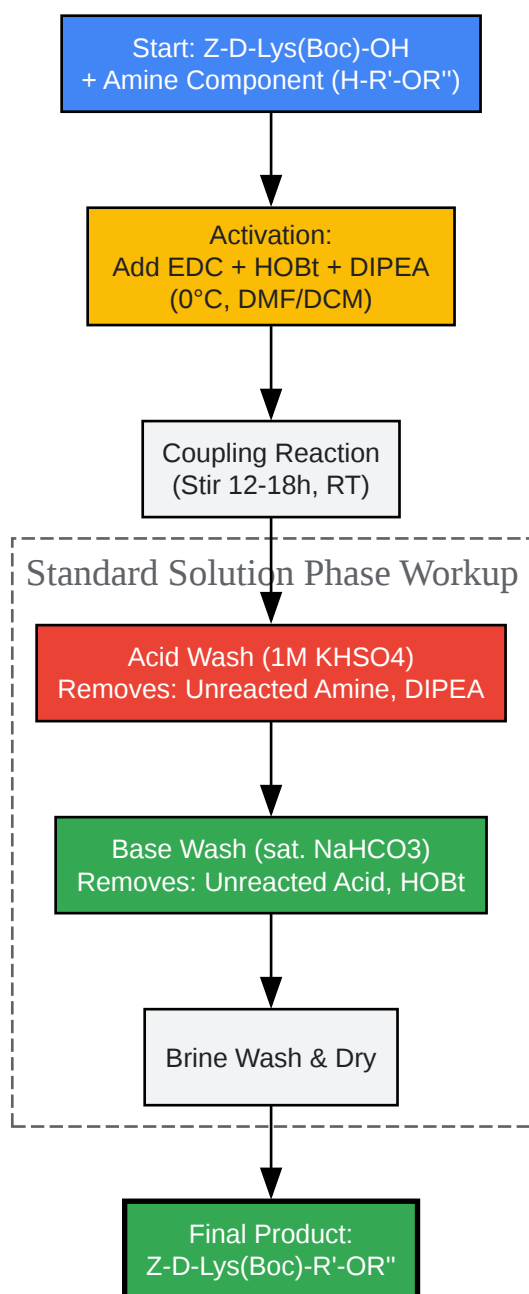

[Click to download full resolution via product page](#)

Figure 2: Standard Solution Phase Coupling Workflow utilizing Acid/Base extraction for purification.

Step-by-Step:

- Dissolution: Dissolve Z-D-Lys(Boc)-OH (1.0 eq) and the Amine Component (1.1 eq) in DCM or DMF.

- Activation: Add HOBt (1.2 eq). Cool to 0 °C.
- Coupling: Add EDC
HCl (1.2 eq) and DIPEA (2.0 eq).
- Reaction: Stir at 0 °C for 1 hour, then RT overnight.
- Extraction (The "Wash"): Dilute with excess EtOAc.
 - Wash
with 1M KHSO
(Removes unreacted amine).
 - Wash
with Sat. NaHCO
(Removes unreacted acid and HOBt).
 - Wash
with Brine.
- Result: Evaporation yields the protected dipeptide, often sufficiently pure (>95%) for the next step without chromatography.

Troubleshooting & Critical Quality Attributes

Issue	Probable Cause	Corrective Action
Racemization (D L)	High pH during saponification or high temp during coupling.	Use LiOH at 0°C. Use HOBt or HOAt during coupling. Avoid excess base.
Incomplete Hydrogenolysis	Catalyst poisoning (Sulfur) or insufficient pressure.	Use fresh Pd/C. Ensure solvent is sulfur-free. Add 1-2 drops of Acetic Acid to accelerate.
Boc Removal	Unexpected acid exposure.	Ensure workup acid (KHSO ₅) is cold and contact time is short. Do not use strong HCl for washes.
Emulsions	Amphiphilic nature of protected peptide.	Add a small amount of MeOH or brine to break the emulsion. Filter through Celite.

References

- Sigma-Aldrich. Product Specification: H-Lys(Boc)-OMe hydrochloride. Retrieved from [Sigma-Aldrich](#)
- Bachem. Efficient Peptide Synthesis: A Guide to Coupling Reagents & Additives. Retrieved from [Bachem](#)
- National Institutes of Health (PMC). The Unexpected Advantages of Using D-Amino Acids for Peptide Self-Assembly. Retrieved from [National Institutes of Health \(PMC\)](#)
- Royal Society of Chemistry. Speeding up sustainable solution-phase peptide synthesis using T3P. Green Chemistry. Retrieved from [Royal Society of Chemistry](#)
- Chem-Impex. N-alpha-Z-N-epsilon-Boc-D-lysine methyl ester Product Data. Retrieved from [Chem-Impex](#)

Need Custom Synthesis?

BenchChem offers custom synthesis for rare earth carbides and specific isotopic labeling.

Email: info@benchchem.com or [Request Quote Online](#).

Sources

- [1. chemimpex.com \[chemimpex.com\]](https://www.chemimpex.com)
- To cite this document: BenchChem. [solution-phase peptide synthesis using Z-D-Lys(boc)-ome]. BenchChem, [2026]. [Online PDF]. Available at: [<https://www.benchchem.com/product/b2770620/docs#solution-phase-peptide-synthesis-using-z-d-lys-boc-ome>]

Disclaimer & Data Validity:

The information provided in this document is for Research Use Only (RUO) and is strictly not intended for diagnostic or therapeutic procedures. While BenchChem strives to provide accurate protocols, we make no warranties, express or implied, regarding the fitness of this product for every specific experimental setup.

Technical Support: The protocols provided are for reference purposes. Unsure if this reagent suits your experiment?

Need Industrial/Bulk Grade? [Request Custom Synthesis Quote](#)

BenchChem

Our mission is to be the trusted global source of essential and advanced chemicals, empowering scientists and researchers to drive progress in science and industry.

Contact

Address: 3281 E Guasti Rd
Ontario, CA 91761, United States
Phone: (601) 213-4426
Email: info@benchchem.com

[Contact our Ph.D. Support Team for a compatibility check](#)

