

Comparative Guide: UV-Vis Absorption Spectra of 3,4-Dimethoxy Substituted Butenoates

Author: BenchChem Technical Support Team. **Date:** February 2026

Compound of Interest

Compound Name: Ethyl 2-cyano-3-(3,4-dimethoxyphenyl)but-2-enoate

CAS No.: 15854-05-4

Cat. No.: B2765981

[Get Quote](#)

Executive Summary

This technical guide characterizes the ultraviolet-visible (UV-Vis) absorption profile of 3,4-dimethoxy substituted butenoates (structurally analogous to 3,4-dimethoxycinnamates or veratric acid esters). These compounds are critical intermediates in the synthesis of isoquinoline alkaloids and UV-B filtering agents.

Key Finding: The introduction of the 3,4-dimethoxy motif induces a significant bathochromic (red) shift (

) and a hyperchromic effect compared to unsubstituted analogs. This is driven by the synergistic electron-donating capacity of the methoxy groups into the conjugated ester system, reducing the HOMO-LUMO energy gap.

Structural Context & Electronic Theory[1]

To interpret the spectra accurately, one must understand the electronic "push-pull" mechanism inherent in these molecules.

The Chromophore System

The core chromophore consists of a benzene ring conjugated with an

-unsaturated ester (the butenoate/cinnamate tail).

- Acceptor (Pull): The ester carbonyl group withdraws electron density via the

-system.

- Donor (Push): The methoxy groups (-OCH

) at positions 3 and 4 act as strong auxochromes. Through the mesomeric effect (+M), they donate lone pair electrons into the aromatic ring, which are then delocalized across the alkene double bond.

The "Veratryl" Effect

Unlike mono-substituted analogs (e.g., 4-methoxy), the 3,4-dimethoxy (veratryl) pattern creates a broader electron distribution. This raises the energy of the Highest Occupied Molecular Orbital (HOMO) while the Lowest Unoccupied Molecular Orbital (LUMO) remains relatively stabilized by the ester. The result is a lower energy

transition, shifting absorption into the UVA/UVB boundary region.

Mechanistic Visualization

The following diagram illustrates the electronic causality leading to the spectral shift.

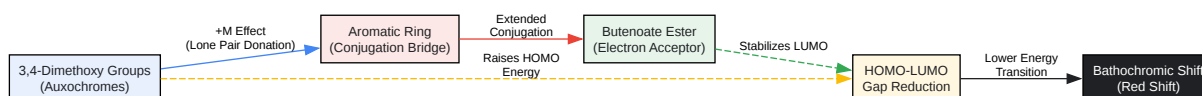

[Click to download full resolution via product page](#)

Figure 1: Electronic flow illustrating the "Push-Pull" mechanism responsible for the spectral redshift in 3,4-dimethoxy butenoates.

Comparative Spectral Analysis

The following data compares the 3,4-dimethoxy derivative against structural alternatives to isolate the substituent effects. Data represents values in Methanol (MeOH), a standard solvent

for these polar organic molecules.

Compound Class	Structure	(nm)	Molar Absorptivity ()	Electronic Transition
Unsubstituted	Methyl Cinnamate	277 nm	~22,000	
Mono-substituted	Methyl 4-Methoxycinnamate	310 nm	~24,000	(CT character)
Target Compound	Methyl 3,4-Dimethoxycinnamate	324 nm	~18,500 - 21,000	(Strong CT)
Saturated Analog	Methyl 3,4-Dimethoxybenzoate	295 nm	~6,500	(No alkene)

Analysis:

- Conjugation Effect: Comparing the Target Compound (324 nm) with the Saturated Analog (295 nm) confirms that the alkene double bond adds ~30 nm to the shift, validating the "butenoate" conjugation necessity.
- Substituent Effect: Adding the second methoxy group (moving from 4-methoxy to 3,4-dimethoxy) shifts

from 310 nm to 324 nm. This fine-tunes the absorption profile, making it highly specific for UV-A/B boundary detection.

Experimental Protocol: Determination of Molar Absorptivity

To generate reproducible data for regulatory or publication purposes, the following self-validating protocol must be used. This method accounts for solvent cut-offs and concentration

linearity (Beer-Lambert Law).

Reagents & Equipment

- Analyte: Methyl 3,4-dimethoxybut-2-enoate (High purity >98%).
- Solvent: HPLC-grade Methanol (Cut-off <205 nm). Do not use Acetone (Cut-off 330 nm interferes with
(
)).
- Instrument: Double-beam UV-Vis Spectrophotometer (Scan range 200–500 nm).
- Cuvettes: Quartz (1 cm path length). Glass absorbs UV and invalidates results.

Step-by-Step Workflow

Step 1: Stock Solution Preparation Weigh ~10 mg of analyte accurately. Dissolve in 100 mL Methanol to create a stock concentration (

).

Step 2: Serial Dilution (Self-Validation Step) Prepare 5 dilutions ranging from

to

.

- Validation: If the absorbance of the highest concentration exceeds 1.5 AU, dilute further to avoid non-linearity errors.

Step 3: Spectral Scanning Run a baseline correction with pure Methanol. Scan each sample from 500 nm down to 200 nm. Note the absorbance (

) at

(approx. 324 nm).

Step 4: Calculation & Regression Plot Absorbance (

) vs. Concentration (

).

- Calculate linear regression:

.

- The slope

equals the Molar Absorptivity (

).[\[1\]](#)[\[2\]](#)

- Acceptance Criteria:

.

Protocol Visualization

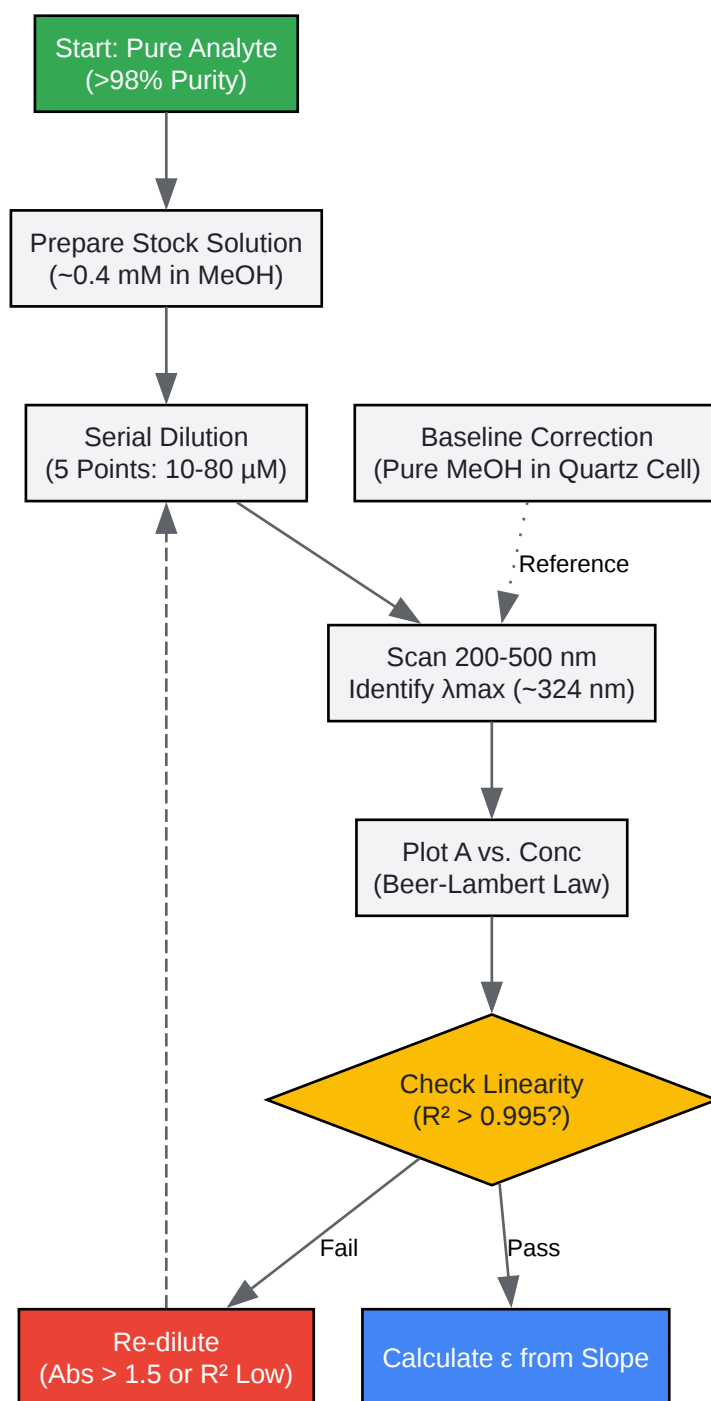

[Click to download full resolution via product page](#)

Figure 2: Operational workflow for the accurate determination of molar absorptivity (), ensuring data integrity via linearity checks.

Applications in Drug Discovery

Understanding the spectra of 3,4-dimethoxy butenoates is not merely academic; it has direct translational value:

- **Metabolic Tracking:** The 3,4-dimethoxy motif is often a metabolic product of catechol-O-methyltransferase (COMT) acting on dihydroxy precursors. The distinct shift to 324 nm allows HPLC-UV detection of methylated metabolites in plasma without interference from protein absorption (typically <280 nm).

- **Photoprotection (Sunscreens):** Due to the high

and absorption in the UV-B/A boundary (320–340 nm), these derivatives are evaluated as "broad-spectrum" boosters in sunscreen formulations, often outperforming mono-methoxy analogs in UVA protection.

References

- NIST Chemistry WebBook. UV/Visible Spectrum of Methyl 3,4-dimethoxycinnamate. National Institute of Standards and Technology. [\[Link\]](#)
- Taniguchi, M., et al. (2015). Benchmark studies of UV-vis spectra simulation for cinnamates with UV filter profile. Journal of Molecular Modeling. [\[Link\]](#)
- University of Toronto. Interpreting UV-Vis Spectra: Effects of Conjugation and Substituents. [\[Link\]](#)
- LibreTexts Chemistry. UV-Visible Absorption Spectroscopy: Molar Absorptivity and Beer-Lambert Law. [\[Link\]](#)

Need Custom Synthesis?

BenchChem offers custom synthesis for rare earth carbides and specific isotopic labeling.

Email: info@benchchem.com or [Request Quote Online](#).

Sources

- 1. chem.libretexts.org [\[chem.libretexts.org\]](#)

- [2. uregina.ca \[uregina.ca\]](#)
- To cite this document: BenchChem. [Comparative Guide: UV-Vis Absorption Spectra of 3,4-Dimethoxy Substituted Butenoates]. BenchChem, [2026]. [Online PDF]. Available at: [<https://www.benchchem.com/product/b2765981#uv-vis-absorption-spectra-of-3-4-dimethoxy-substituted-butenoates>]

Disclaimer & Data Validity:

The information provided in this document is for Research Use Only (RUO) and is strictly not intended for diagnostic or therapeutic procedures. While BenchChem strives to provide accurate protocols, we make no warranties, express or implied, regarding the fitness of this product for every specific experimental setup.

Technical Support: The protocols provided are for reference purposes. Unsure if this reagent suits your experiment? [[Contact our Ph.D. Support Team for a compatibility check](#)]

Need Industrial/Bulk Grade? [Request Custom Synthesis Quote](#)

BenchChem

Our mission is to be the trusted global source of essential and advanced chemicals, empowering scientists and researchers to drive progress in science and industry.

Contact

Address: 3281 E Guasti Rd

Ontario, CA 91761, United States

Phone: (601) 213-4426

Email: info@benchchem.com