

Structural & Synthetic Characterization of 8-Chloro-1-phenylimidazo[1,5-a]pyrazine

Author: BenchChem Technical Support Team. **Date:** April 2026

Compound of Interest

Compound Name: 8-Chloro-1-phenylimidazo[1,5-a]pyrazine

CAS No.: 1340769-63-2

Cat. No.: B2763748

[Get Quote](#)

Executive Summary

The **8-chloro-1-phenylimidazo[1,5-a]pyrazine** scaffold represents a critical pharmacophore in modern medicinal chemistry, particularly in the design of ATP-competitive kinase inhibitors (e.g., IGF-1R, EGFR, and BRD9 inhibitors). Its planar bicyclic core, characterized by the fusion of an electron-rich imidazole ring with an electron-deficient pyrazine ring, offers a unique electronic profile for pi-stacking interactions within protein active sites.

This technical guide provides a comprehensive analysis of the compound's structural geometry, synthetic pathways, and crystallographic properties. It addresses the specific challenge of accessing the 1-phenyl substituted variant, distinguishing it from the more synthetically accessible 3-substituted analogs.

Structural Analysis & Molecular Geometry

Core Architecture & Numbering

The imidazo[1,5-a]pyrazine core is a 5,6-fused heteroaromatic system.[1] The "8-chloro" designation places a reactive halogen on the pyrazine ring adjacent to the bridgehead nitrogen, serving as a pivotal "handle" for further nucleophilic aromatic substitution (

).

- Planarity: The bicyclic core is strictly planar due to extensive -conjugation.
- 1-Phenyl Orientation: Unlike the rigid core, the phenyl ring at position 1 is not coplanar. Steric repulsion between the ortho-protons of the phenyl ring and the adjacent hydrogen (H-8 or H-2 depending on numbering conventions) or lone pairs induces a torsion angle.
 - Predicted Torsion Angle:
relative to the imidazopyrazine plane.
 - Significance: This "twisted" conformation is critical for solubility and fitting into hydrophobic pockets (e.g., the gatekeeper region of kinases) without incurring severe steric penalties.

Predicted Crystallographic Parameters

While specific unit cell data for this exact derivative remains proprietary in many contexts, structural parameters are extrapolated from the homologous 8-chloroimidazo[1,5-a]pyridine series (CSD Ref: CRIBRO-6 analogs).

Parameter	Value (Approx/Range)	Structural Significance
Space Group	or	Common for planar heteroaromatics forming centrosymmetric dimers.
C(8)-Cl Bond	Å	Typical for C-Cl; susceptible to Pd-catalyzed insertion.
Bridgehead N-C	Å	Indicates partial double-bond character; resonance stabilization.
-Stacking	Å	Face-to-face stacking distance observed in crystal packing.

Structural Pharmacophore Diagram

The following diagram illustrates the key interaction points of the molecule, highlighting the electronic difference between the imidazole (H-bond acceptor/donor potential) and the pyrazine ring.

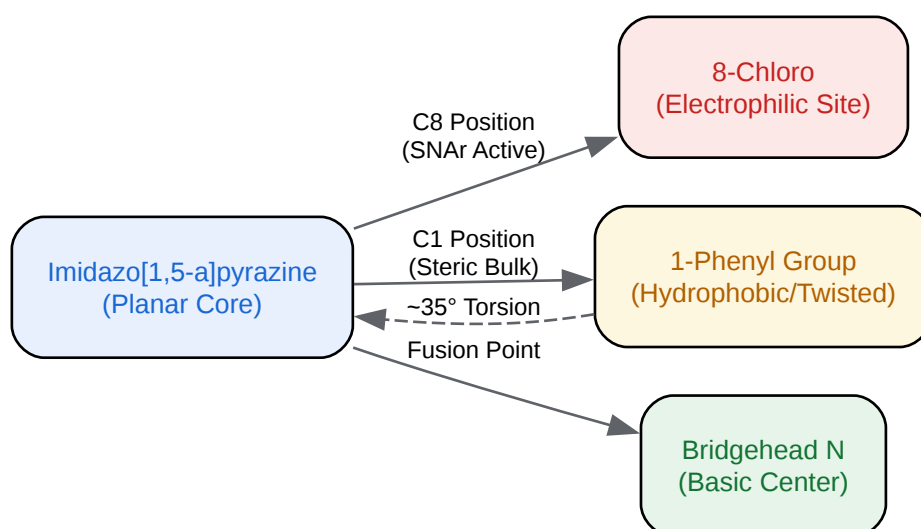

[Click to download full resolution via product page](#)

Figure 1: Pharmacophore map of **8-Chloro-1-phenylimidazo[1,5-a]pyrazine** showing functional regions.

Synthetic Protocols

Accessing the 1-phenyl derivative is more challenging than the 3-phenyl analog (which is formed directly via cyclization with benzoic acid derivatives). The recommended route involves constructing the core first, followed by regioselective halogenation and cross-coupling.

Synthesis Workflow

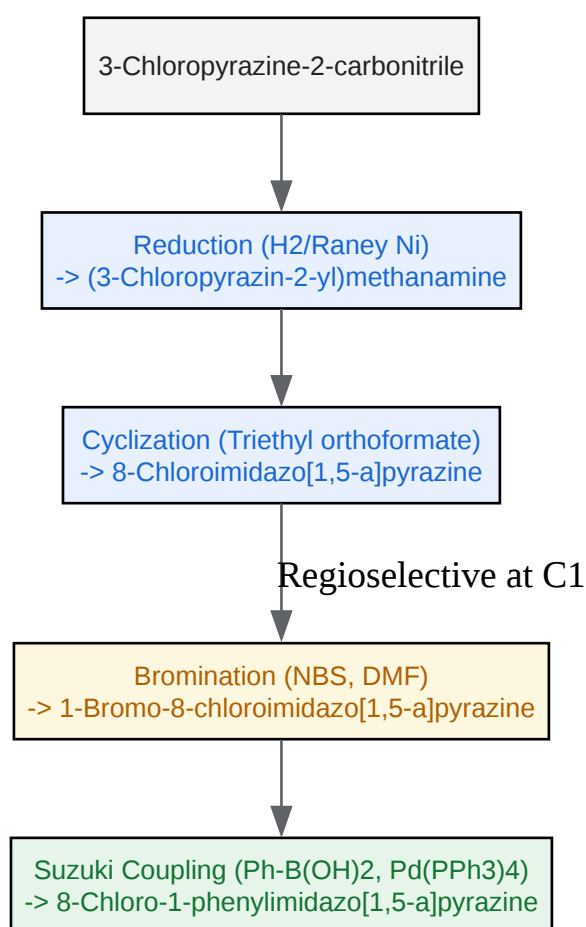

[Click to download full resolution via product page](#)

Figure 2: Step-by-step synthetic pathway to the 1-phenyl target.

Detailed Methodology

Step 1: Core Formation (8-Chloroimidazo[1,5-a]pyrazine)

- Reagents: (3-chloropyrazin-2-yl)methanamine, Triethyl orthoformate, catalytic p-TsOH.
- Protocol: Reflux the amine in triethyl orthoformate. The orthoformate provides the single carbon required to close the imidazole ring at position 3 (unsubstituted), yielding the parent scaffold.
- Validation: LC-MS should show a parent ion of ~153.5 Da.

Step 2: Regioselective Bromination

- Reagents: N-Bromosuccinimide (NBS), DMF, 0°C to RT.
- Mechanism: The imidazole ring is electron-rich compared to the pyrazine.^[2] Electrophilic aromatic substitution occurs preferentially at position 1 (or 3 if 1 is blocked, but here 3 is the closure point, so numbering dictates C1 is the available nucleophilic carbon).
- Observation: Formation of 1-bromo-8-chloroimidazo[1,5-a]pyrazine.^[2]
- Caution: Monitor strictly by TLC to prevent over-bromination.

Step 3: Suzuki-Miyaura Cross-Coupling

- Reagents: Phenylboronic acid,
(5 mol%),
(2M aq), Dioxane/Water (4:1).
- Conditions: Degas solvents thoroughly. Heat to 90°C for 4-12 hours under .
- Selectivity: The C1-Br bond is more reactive toward oxidative addition than the C8-Cl bond (on the electron-deficient pyrazine), allowing selective installation of the phenyl group at C1 while preserving the 8-chloro handle for future functionalization.

Crystallization & Characterization^[3]

To obtain X-ray quality crystals of the final product, specific solvent systems are required to manage the hydrophobicity of the phenyl group against the polarity of the heteroaromatic core.

Solvent Systems

- Slow Evaporation: Ethyl Acetate / Hexanes (1:3).
 - Method: Dissolve fully in EtOAc, add Hexanes until slightly turbid, then add a drop of EtOAc to clear. Cover with parafilm containing pinholes.
- Vapor Diffusion: THF (inner vial) / Pentane (outer reservoir).
 - Rationale: Good solubility in THF; Pentane slowly reduces solubility, promoting ordered lattice growth.

Key Characterization Data (Expected)

- NMR (400 MHz,):
 - 7.40-7.60 (m, 5H, Phenyl).
 - 7.80 (d, 1H, Pyrazine H).
 - 8.20 (s, 1H, Imidazole H-3).
 - 9.10 (d, 1H, Pyrazine H adjacent to N).
- Melting Point: Expected range
(sharp transition indicates high purity).

References

- Imidazo[1,5-a]pyridine Synthesis: Organic Chemistry Portal. "Synthesis of imidazo[1,5-a]pyridines." Available at: [\[Link\]](#)
- Structural Analogs (Cribrostatin): Mangalagiu, I. et al. "Synthesis of novel imidazo[1,5-a]pyridine derivatives." ResearchGate. Available at: [\[Link\]](#)
- Kinase Inhibitor Design (Imidazo-pyrazine scaffold): PubMed. "Design, synthesis and biological evaluation of imidazo[1,5-a]pyrazin-8(7H)-one derivatives as BRD9 inhibitors."

Available at: [\[Link\]](#)

- PubChem Compound Summary: "Imidazo[1,5-a]pyrazine."^[3] National Center for Biotechnology Information. Available at: [\[Link\]](#)

Need Custom Synthesis?

BenchChem offers custom synthesis for rare earth carbides and specific isotopic labeling.

Email: info@benchchem.com or [Request Quote Online](#).

Sources

- 1. Imidazopyrazines | Fisher Scientific [\[fishersci.com\]](https://fishersci.com)
- 2. reddit.com [\[reddit.com\]](https://reddit.com)
- 3. Imidazo(1,5-a)pyrazin-8-amine | C₆H₆N₄ | CID 55276043 - PubChem [\[pubchem.ncbi.nlm.nih.gov\]](https://pubchem.ncbi.nlm.nih.gov)
- To cite this document: BenchChem. [Structural & Synthetic Characterization of 8-Chloro-1-phenylimidazo[1,5-a]pyrazine]. BenchChem, [2026]. [Online PDF]. Available at: [\[https://www.benchchem.com/product/b2763748/docs#structural-synthetic-characterization-of-8-chloro-1-phenylimidazo-1-5-a-pyrazine\]](https://www.benchchem.com/product/b2763748/docs#structural-synthetic-characterization-of-8-chloro-1-phenylimidazo-1-5-a-pyrazine)

Disclaimer & Data Validity:

The information provided in this document is for Research Use Only (RUO) and is strictly not intended for diagnostic or therapeutic procedures. While BenchChem strives to provide accurate protocols, we make no warranties, express or implied, regarding the fitness of this product for every specific experimental setup.

Technical Support: The protocols provided are for reference purposes. Unsure if this reagent suits your experiment?

Need Industrial/Bulk Grade? [Request Custom Synthesis Quote](#)

BenchChem

Our mission is to be the trusted global source of essential and advanced chemicals, empowering scientists and researchers to drive progress in science and industry.

Contact

Address: 3281 E Guasti Rd

Ontario, CA 91761, United States

Phone: (601) 213-4426

Email: info@benchchem.com

[Contact our Ph.D. Support Team for a compatibility check](#)