

Technical Support Center: Optimizing Suzuki Coupling Reactions for Bromopyrazines

Author: BenchChem Technical Support Team. **Date:** May 2026

Compound of Interest

Compound Name: 6-Bromopyrazin-2-ol

CAS No.: 859063-85-7

Cat. No.: B2754270

[Get Quote](#)

Introduction

Welcome to the technical support center for optimizing Suzuki-Miyaura cross-coupling reactions involving bromopyrazines. Pyrazine rings are critical components in numerous pharmaceuticals, agrochemicals, and functional materials. However, their electron-deficient nature presents unique challenges in carbon-carbon bond formation. This guide is designed for researchers, scientists, and drug development professionals to provide in-depth, field-proven insights for troubleshooting common issues and enhancing reaction outcomes.

This resource moves beyond simple protocols to explain the causality behind experimental choices, ensuring you can adapt and optimize your specific reaction with confidence.

Section 1: The Suzuki-Miyaura Reaction & The Bromopyrazine Challenge

The Suzuki-Miyaura coupling is a cornerstone of modern synthesis, enabling the formation of C-C bonds between an organoboron species (like a boronic acid) and an organohalide. The

reaction is catalyzed by a palladium(0) complex and proceeds through a generally accepted catalytic cycle.

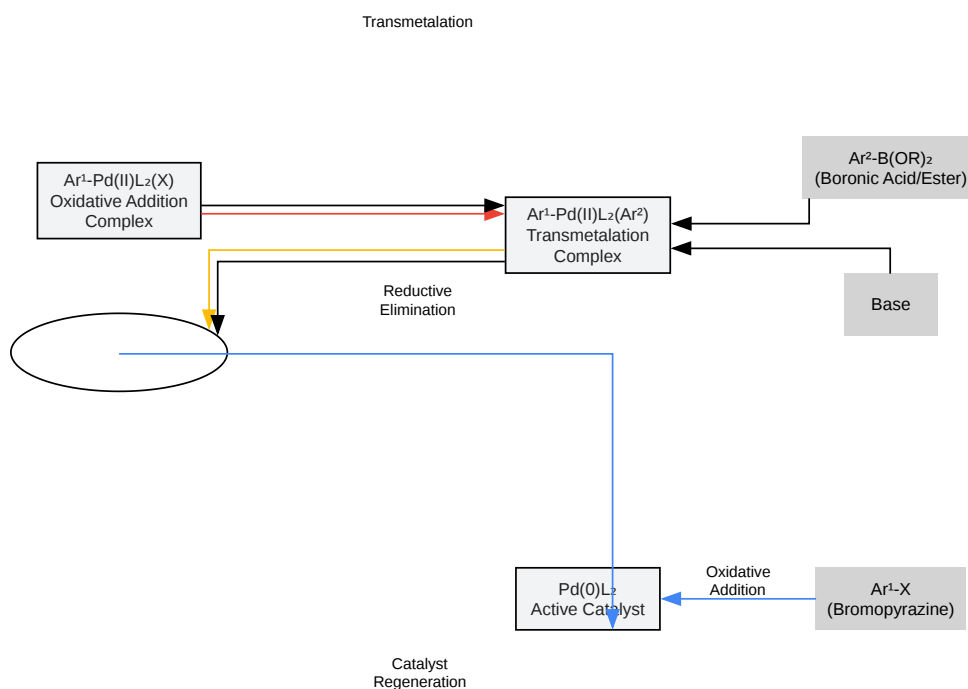

Figure 1. The Suzuki-Miyaura Catalytic Cycle

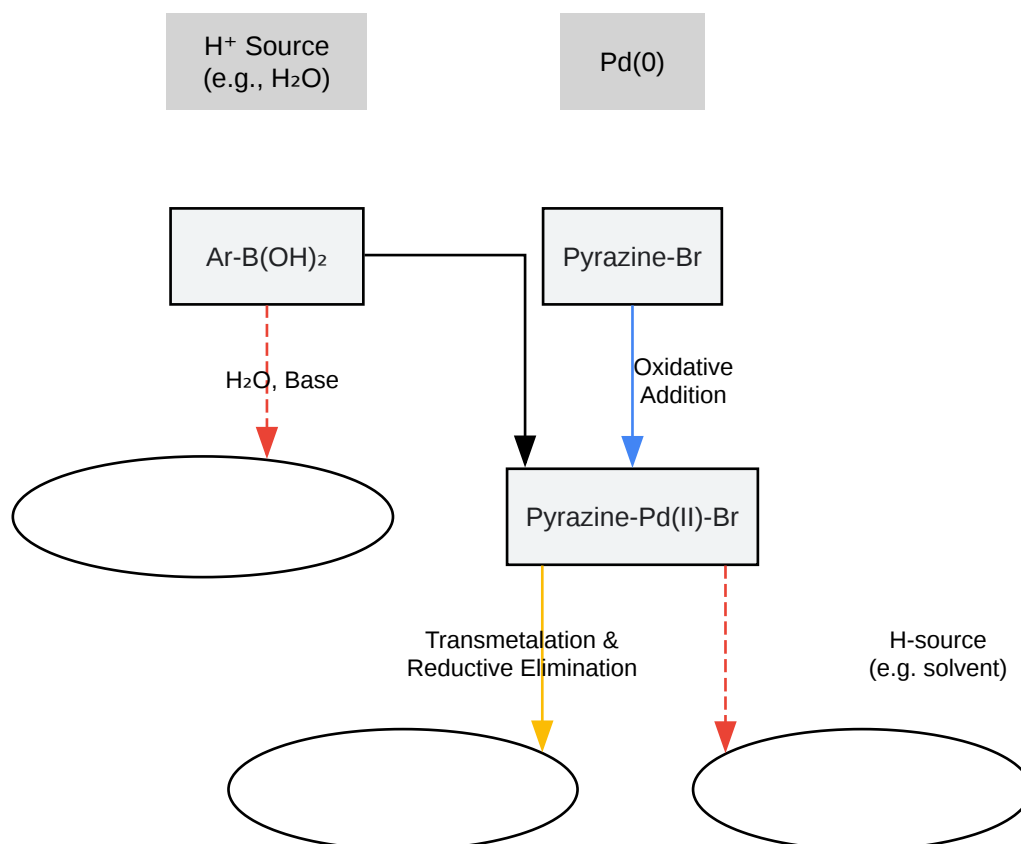

Figure 2. Common Side Reaction Pathways

[Click to download full resolution via product page](#)

Caption: Figure 2. Common Side Reaction Pathways

Causality & Solutions:

- Protodeboronation: This is the hydrolysis of the boronic acid's C-B bond, replacing it with a C-H bond. It is often accelerated by excess water, high temperatures, and certain bases. [1] [2] Heteroaryl boronic acids can be particularly susceptible. [3] * Solution 1: Use Boronic Esters: Pinacol (BPin) or MIDA esters are significantly more stable to protodeboronation than the corresponding boronic acids. [4] * Solution 2: Minimize Water: While a small amount of water can be beneficial, excess water promotes this side reaction. Use anhydrous solvents and consider a base like CsF which can be used under anhydrous conditions.
 - Solution 3: Degas Thoroughly: Oxygen can accelerate decomposition pathways. Sparge your solvent and reaction mixture with an inert gas (Nitrogen or Argon) for 15-30 minutes before heating.

- Dehalogenation: This is the replacement of the C-Br bond with a C-H bond on the pyrazine ring. It can occur if the transmetalation step is slow, allowing the Pd(II)-pyrazinyl intermediate to react with a hydrogen source instead. [3] * Solution 1: Increase Boronic Acid Equivalents: Using a slight excess of the boronic acid partner (e.g., 1.2-1.5 equivalents) can kinetically favor the transmetalation step over dehalogenation.
 - Solution 2: More Active Catalyst: A more active catalyst system (e.g., using SPhos instead of PPh₃) can accelerate the entire catalytic cycle, minimizing the lifetime of the intermediate susceptible to dehalogenation.
 - Solution 3: Change the Base/Solvent: Sometimes a change in base (e.g., from K₂CO₃ to K₃PO₄) can dramatically alter the rate of transmetalation relative to dehalogenation.

Section 3: Standardized Experimental Protocol

This section provides a robust, general-purpose protocol for the Suzuki-Miyaura coupling of a generic bromopyrazine with an arylboronic acid.

General Protocol for Suzuki Coupling of Bromopyrazine

Materials:

- Bromopyrazine (1.0 mmol, 1.0 equiv)
- Arylboronic Acid (1.2 mmol, 1.2 equiv)
- SPhos-Pd-G3 pre-catalyst (0.02 mmol, 2 mol%)
- Potassium Phosphate (K₃PO₄), finely ground (3.0 mmol, 3.0 equiv)
- 1,4-Dioxane (5 mL)
- Deionized Water (0.5 mL)

Procedure:

- Vessel Preparation: To a flame-dried Schlenk flask or microwave vial equipped with a magnetic stir bar, add the bromopyrazine, arylboronic acid, SPhos-Pd-G3, and K₃PO₄.

- **Inert Atmosphere:** Seal the vessel with a septum or cap. Evacuate the flask and backfill with an inert gas (Argon or Nitrogen). Repeat this cycle three times to ensure an oxygen-free environment.
- **Solvent Addition:** Add the 1,4-dioxane and water via syringe. The mixture should be a suspension.
- **Degassing (Optional but Recommended):** Bubble the inert gas through the stirred suspension for 10-15 minutes.
- **Reaction:** Place the sealed vessel in a preheated oil bath or heating block at 100 °C.
- **Monitoring:** Monitor the reaction progress by taking small aliquots and analyzing by LC-MS or TLC. A typical reaction time is 4-12 hours.
- **Workup:** After completion, cool the reaction to room temperature. Dilute with ethyl acetate (20 mL) and water (10 mL). Separate the organic layer, wash with brine (15 mL), dry over anhydrous sodium sulfate (Na_2SO_4), filter, and concentrate under reduced pressure.
- **Purification:** Purify the crude product by flash column chromatography on silica gel.

Section 4: Frequently Asked Questions (FAQs)

Q1: Can I run these reactions open to the air? While some modern pre-catalysts are air-stable for weighing, the reaction itself is sensitive to oxygen. Oxygen can oxidize the active Pd(0) catalyst to inactive Pd(II) species and promote side reactions. For consistent and high-yielding results, using an inert atmosphere is strongly recommended.

Q2: My boronic acid is expensive. How can I avoid using a large excess? If dehalogenation is a major issue and you need to preserve your boronic acid, focus on optimizing the other parameters first. Ensure your catalyst system is highly active (e.g., using a biarylphosphine ligand) and that your base and solvent are optimal. Sometimes, switching from a boronic acid to a more reactive boronic ester (like a pinacol ester) can improve efficiency enough to allow for near-stoichiometric use.

Q3: What is the black precipitate that sometimes forms in my reaction? This is typically "palladium black," which is finely divided, inactive palladium metal. It forms when the Pd(0)

catalyst aggregates and falls out of the catalytic cycle. This is a sign of catalyst decomposition and is often caused by:

- Insufficient ligand to stabilize the Pd(0) species.
- Reaction temperature being too high for the chosen ligand.
- Presence of impurities that poison the catalyst. Using bulky, electron-rich ligands like SPhos or XPhos helps prevent the formation of palladium black.

Q4: How do I choose between an inorganic base (like K_3PO_4) and an organic base (like TEA)? For Suzuki couplings, inorganic bases are almost always required. [5]The base's primary role is to form an "ate" complex with the boronic acid, $[ArB(OH)_3]^-$, which is essential for the transmetalation step. Organic amine bases like triethylamine (TEA) are generally not basic enough to perform this function effectively in this context.

References

- BenchChem Technical Support Team. (2025). Technical Support Center: Optimizing Reactions with 2-Bromopyrazine. BenchChem.
- Kotha, S., Lahiri, K., & Kashinath, D. (2002). Recent applications of the Suzuki–Miyaura cross-coupling reaction in organic synthesis. *Tetrahedron*, 58(48), 9633–9695.
- Thomas, S., & Carrow, B. P. (2018). Elucidating the Role of the Boronic Esters in the Suzuki–Miyaura Reaction: Structural, Kinetic, and Computational Investigations.
- Cox, P. A., et al. (2016). Suzuki–Miyaura Coupling. In *Synthetic Methods in Drug Discovery* (Vol. 1, pp. 1-38). Royal Society of Chemistry.
- Yoneda Labs. (n.d.). Suzuki-Miyaura cross-coupling: Practical Guide. Yoneda Labs.
- Wikipedia contributors. (2023, November 29). Protodeboronation. In *Wikipedia, The Free Encyclopedia*.
- Walker, S. D., et al. (2004). Palladium-Catalyzed Suzuki-Miyaura Cross-coupling Reactions Employing Dialkylbiaryl Phosphine Ligands.

Need Custom Synthesis?

BenchChem offers custom synthesis for rare earth carbides and specific isotopic labeling.

Email: info@benchchem.com or [Request Quote Online](#).

Sources

- [1. books.rsc.org \[books.rsc.org\]](https://books.rsc.org)
- [2. Protodeboronation - Wikipedia \[en.wikipedia.org\]](https://en.wikipedia.org)
- [3. Yoneda Labs \[yonedalabs.com\]](https://yonedalabs.com)
- [4. Elucidating the Role of the Boronic Esters in the Suzuki–Miyaura Reaction: Structural, Kinetic, and Computational Investigations - PMC \[pmc.ncbi.nlm.nih.gov\]](https://pubmed.ncbi.nlm.nih.gov)
- [5. uwindsor.ca \[uwindsor.ca\]](https://uwindsor.ca)
- To cite this document: BenchChem. [Technical Support Center: Optimizing Suzuki Coupling Reactions for Bromopyrazines]. BenchChem, [2026]. [Online PDF]. Available at: [\[https://www.benchchem.com/product/b2754270/docs#technical-support-center-optimizing-suzuki-coupling-reactions-for-bromopyrazines\]](https://www.benchchem.com/product/b2754270/docs#technical-support-center-optimizing-suzuki-coupling-reactions-for-bromopyrazines)

Disclaimer & Data Validity:

The information provided in this document is for Research Use Only (RUO) and is strictly not intended for diagnostic or therapeutic procedures. While BenchChem strives to provide accurate protocols, we make no warranties, express or implied, regarding the fitness of this product for every specific experimental setup.

Technical Support: The protocols provided are for reference purposes. Unsure if this reagent suits your experiment?

Need Industrial/Bulk Grade? [Request Custom Synthesis Quote](#)

BenchChem

Our mission is to be the trusted global source of essential and advanced chemicals, empowering scientists and researchers to drive progress in science and industry.

Contact

Address: 3281 E Guasti Rd
Ontario, CA 91761, United States
Phone: (601) 213-4426
Email: info@benchchem.com

Contact our Ph.D. Support Team for a compatibility check