

# Technical Support Center: Navigating Regioselectivity in Pyrazole Ring Formation

**Author:** BenchChem Technical Support Team. **Date:** May 2026

## Compound of Interest

Compound Name: 4-[2-nitro-4-(1H-pyrazol-5-yl)phenyl]morpholine

CAS No.: 1033847-04-9

Cat. No.: B2749467

[Get Quote](#)

Welcome to the technical support center dedicated to resolving the complex challenge of regioselectivity in pyrazole synthesis. This guide is designed for researchers, scientists, and drug development professionals who encounter the common yet critical issue of controlling isomeric outcomes in their pyrazole-forming reactions. Here, we dissect the underlying principles governing regioselectivity and provide actionable troubleshooting strategies and detailed protocols to empower you to achieve your desired synthetic targets with precision and confidence.

## Introduction: The Regioselectivity Challenge in Pyrazole Synthesis

The pyrazole scaffold is a cornerstone in medicinal chemistry and materials science, valued for its diverse biological activities and versatile applications.<sup>[1][2]</sup> The classical and most prevalent method for pyrazole synthesis, the Knorr condensation of a 1,3-dicarbonyl compound with a hydrazine derivative, often presents a significant hurdle: the formation of a mixture of regioisomers when using unsymmetrical starting materials.<sup>[1][3][4]</sup> This lack of regiocontrol can lead to tedious separation processes, reduced yields of the desired isomer, and ambiguity in

structure-activity relationship (SAR) studies. This guide will illuminate the factors governing this selectivity and provide you with the tools to master it.

## Troubleshooting Guide: Common Regioselectivity Issues and Solutions

This section is designed to be your first point of reference when you encounter unexpected or poor regioselectivity in your pyrazole synthesis.

Problem	Probable Cause(s)	Recommended Solutions & Key Considerations
Formation of a nearly 1:1 mixture of regioisomers.	- Similar steric and electronic properties of the substituents on the 1,3-dicarbonyl compound.[3] - Neutral reaction conditions that do not favor one reaction pathway over another.	- Modify Reaction Conditions: <ul style="list-style-type: none"><li>- pH Control: Under acidic conditions, the reaction can be directed towards a specific outcome.[5] Conversely, basic conditions can favor the attack of the more nucleophilic nitrogen of the hydrazine first.[5]</li><li>- Solvent Effects: The use of fluorinated alcohols like 2,2,2-trifluoroethanol (TFE) or 1,1,1,3,3,3-hexafluoro-2-propanol (HFIP) can dramatically improve regioselectivity compared to standard solvents like ethanol.[5][6][7]</li><li>- Temperature Optimization: Lowering or raising the reaction temperature can sometimes favor the formation of one isomer over the other.[5]</li></ul>
The undesired regioisomer is the major product.	- The inherent electronic and steric properties of your substrates favor the formation of the undesired isomer under standard conditions.[5]	- Employ Dicarbonyl Surrogates: Instead of a 1,3-diketone, consider using a $\beta$ -enaminone or an $\alpha$ -oxoketene N,S-acetal. These substrates have pre-defined differences in the reactivity of their electrophilic centers, forcing the reaction to proceed with high regioselectivity.[5] - Catalysis: Explore the use of catalysts. For instance, Lewis

acids can be employed in multicomponent reactions to achieve regioselective synthesis of highly substituted pyrazoles.[5] Silver catalysts have also been shown to be effective in certain reactions.[1]

---

Inconsistent regioselectivity between batches.	- Subtle variations in reaction conditions (e.g., pH, temperature, moisture content). - Purity of starting materials.	- Standardize Protocols: Ensure consistent and precise control over all reaction parameters. - Purify Starting Materials: Use highly purified 1,3-dicarbonyl compounds and hydrazines.
--	---	--

---

Difficulty in determining the regioisomeric ratio.	- Co-elution of isomers during chromatography. - Ambiguous NMR spectra.	- Advanced Analytical Techniques: - NMR Spectroscopy: Utilize advanced NMR techniques such as 2D NMR (NOESY, HMBC) to elucidate the connectivity of the pyrazole ring substituents. - X-ray Crystallography: If a crystalline product can be obtained, single-crystal X-ray diffraction provides unambiguous structural confirmation of the regioisomer.[8][9][10][11]
--	---	--

---

## Frequently Asked Questions (FAQs)

### Q1: What are the fundamental principles governing regioselectivity in the Knorr pyrazole synthesis?

A1: The regioselectivity in the Knorr pyrazole synthesis is primarily governed by a combination of steric and electronic factors of both the 1,3-dicarbonyl compound and the hydrazine

derivative.<sup>[3][5]</sup> The initial nucleophilic attack of the hydrazine can occur at either of the two carbonyl carbons. The more electrophilic carbonyl carbon is generally attacked first. Steric hindrance around a carbonyl group can disfavor attack at that position. Furthermore, the nucleophilicity of the two nitrogen atoms in a substituted hydrazine can differ, influencing which nitrogen initiates the cyclization.

## Q2: How does the choice of solvent influence regioselectivity?

A2: The solvent can play a crucial role in dictating the regiochemical outcome.<sup>[5]</sup> For instance, fluorinated alcohols like TFE and HFIP have been shown to significantly enhance regioselectivity in the formation of N-methylpyrazoles from 1,3-diketones and methylhydrazine.<sup>[6][7]</sup> These solvents, through their unique hydrogen-bonding properties, can stabilize certain transition states over others, thereby directing the reaction towards a single regioisomer.

## Q3: Are there alternative synthetic methods that offer better regioselectivity than the Knorr synthesis?

A3: Yes, several methods have been developed to overcome the regioselectivity limitations of the Knorr synthesis. These include:

- **1,3-Dipolar Cycloadditions:** This powerful method involves the reaction of a 1,3-dipole (like a diazo compound or nitrile imine) with a dipolarophile (like an alkyne or alkene).<sup>[5][12][13]</sup> This approach often provides excellent control over regioselectivity.
- **Multicomponent Reactions (MCRs):** One-pot MCRs can provide regioselective access to highly substituted pyrazoles, often with the aid of catalysts.<sup>[5][14][15]</sup>
- **Synthesis from N-Alkylated Tosylhydrazones and Terminal Alkynes:** This method has been reported to provide complete regioselectivity for the synthesis of 1,3,5-trisubstituted pyrazoles.<sup>[16][17]</sup>

## Q4: How can I confidently determine the structure of my pyrazole regioisomers?

A4: A combination of spectroscopic techniques is typically employed.

- Nuclear Magnetic Resonance (NMR) Spectroscopy:  $^1\text{H}$  and  $^{13}\text{C}$  NMR are fundamental for initial characterization. For unambiguous structure determination, 2D NMR experiments like Heteronuclear Multiple Bond Correlation (HMBC) and Nuclear Overhauser Effect Spectroscopy (NOESY) are invaluable. HMBC can reveal long-range correlations between protons and carbons, helping to establish the connectivity of substituents to the pyrazole ring. NOESY can show through-space correlations between protons, providing further structural proof.
- X-ray Crystallography: For crystalline compounds, single-crystal X-ray diffraction is the gold standard for structure elucidation, providing definitive proof of the regiochemistry.[\[8\]](#)[\[9\]](#)[\[10\]](#)  
[\[11\]](#)

## Key Experimental Protocols

### Protocol 1: Regioselective Synthesis of a 3,5-Disubstituted Pyrazole Using a Fluorinated Alcohol Solvent

This protocol provides a general method for improving regioselectivity by utilizing 1,1,1,3,3,3-hexafluoro-2-propanol (HFIP) as the solvent.[\[5\]](#)[\[6\]](#)

Materials:

- Unsymmetrical 1,3-diketone (1.0 mmol)
- Methylhydrazine (1.1 mmol)
- 1,1,1,3,3,3-hexafluoro-2-propanol (HFIP) (3 mL)

Procedure:

- To a solution of the unsymmetrical 1,3-diketone (1.0 mmol) in HFIP (3 mL) in a round-bottom flask, add methylhydrazine (1.1 mmol) dropwise at room temperature with stirring.
- Stir the reaction mixture at room temperature and monitor the progress by Thin Layer Chromatography (TLC).

- Upon completion of the reaction, remove the solvent under reduced pressure.
- Purify the crude product by column chromatography on silica gel using an appropriate eluent system (e.g., hexane/ethyl acetate) to isolate the desired regioisomer.
- Characterize the product by NMR spectroscopy to confirm its structure and determine the isomeric ratio.

## Protocol 2: Characterization of Regioisomers by 2D NMR (HMBC)

This protocol outlines the general steps for using HMBC to determine the regiochemistry of a substituted pyrazole.

### Sample Preparation:

- Dissolve a sufficient amount of the purified pyrazole sample in a suitable deuterated solvent (e.g., CDCl<sub>3</sub>, DMSO-d<sub>6</sub>).

### NMR Acquisition:

- Acquire standard <sup>1</sup>H and <sup>13</sup>C{<sup>1</sup>H} NMR spectra to identify all proton and carbon signals.
- Set up and run a standard HMBC experiment on your NMR spectrometer. Typical parameters include a long-range coupling delay optimized for J-couplings of 8-10 Hz.

### Data Analysis:

- Process the 2D HMBC spectrum.
- Identify key long-range correlations. For example, look for a correlation between the N-substituted proton (e.g., N-CH<sub>3</sub>) and the C3 and C5 carbons of the pyrazole ring. The presence or absence of specific correlations will allow you to definitively assign the structure of the regioisomer.

## Visualizing Reaction Pathways and Influencing Factors

To better understand the concepts discussed, the following diagrams illustrate the key mechanistic steps and factors influencing regioselectivity.

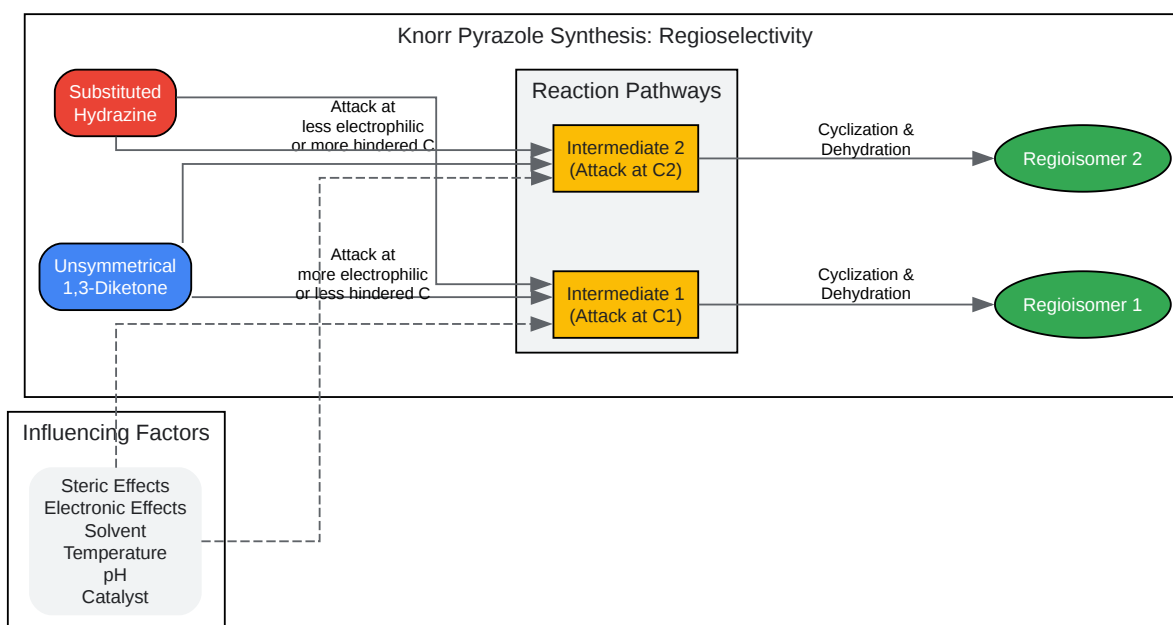

[Click to download full resolution via product page](#)

Caption: Knorr pyrazole synthesis pathways and influencing factors.

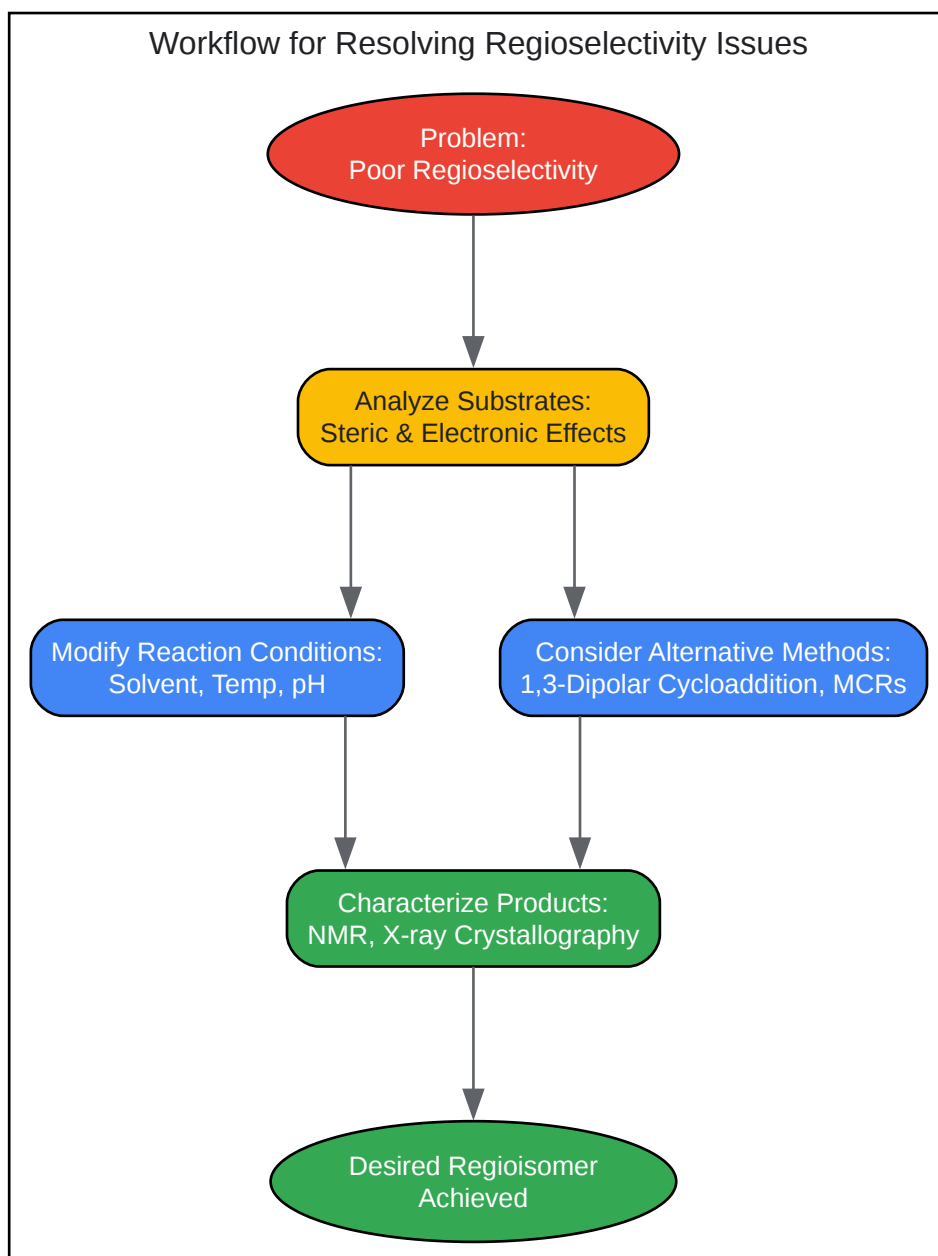

[Click to download full resolution via product page](#)

Caption: A systematic workflow for troubleshooting regioselectivity.

## References

- Kong, Y., Tang, M., & Wang, Y. (2014). Regioselective Synthesis of 1,3,5-Trisubstituted Pyrazoles from N-Alkylated Tosylhydrazones and Terminal Alkynes. *Organic Letters*, 16(3), 576–579. [\[Link\]](#)

- MDPI. (2023). Recent Advances in the Synthesis of Pyrazole Derivatives: A Review. [\[Link\]](#)
- Thieme Chemistry. (2020). Regioselective Synthesis of 3,5-Disubstituted Pyrazoles. [\[Link\]](#)
- American Chemical Society. (2013). Regioselective Synthesis of 1,3,5-Trisubstituted Pyrazoles from N-Alkylated Tosylhydrazones and Terminal Alkynes. [\[Link\]](#)
- Royal Society of Chemistry. (2018). Synthesis of 1,3,5-trisubstituted pyrazoles via 1,3-dipolar cycloaddition of nitrile imines with ninhydrin-derived Morita–Baylis–Hillman carbonates. *Organic & Biomolecular Chemistry*, 16(34), 6250-6254. [\[Link\]](#)
- Semantic Scholar. (2023). A Comprehensive Review on Traditional and Modern Synthetic Approaches to Pyrazole and Its Analogs. [\[Link\]](#)
- American Chemical Society. (2017). Regioselective Synthesis, NMR, and Crystallographic Analysis of N1-Substituted Pyrazoles. *The Journal of Organic Chemistry*, 82(17), 8864–8872. [\[Link\]](#)
- RSC Publishing. (2022). Discovery of unexpectedly complex reaction pathways for the Knorr pyrazole synthesis via transient flow. [\[Link\]](#)
- PMC. (2022). A Review of the Recent Development in the Synthesis and Biological Evaluations of Pyrazole Derivatives. [\[Link\]](#)
- ResearchGate. (2018). Synthesis of 1,3,5-trisubstituted pyrazoles. [\[Link\]](#)
- Organic Chemistry Portal. (2008). Regioselective Synthesis of 1,3,5-Tri- and 1,3,4,5-Tetrasubstituted Pyrazoles from N-Arylhydrazones and Nitroolefins. [\[Link\]](#)
- Hilaris Publisher. (2015). A Concise Review on the Synthesis of Pyrazole Heterocycles. [\[Link\]](#)
- Taylor & Francis. (2017). Green Methods for the Synthesis of Pyrazoles: A Review. [\[Link\]](#)
- ResearchGate. (2016). Proposed structural factors influencing on the regioselectivity of NH-pyrazole alkylations. [\[Link\]](#)

- Bentham Science. (2011). Recent Advances in the Regioselective Synthesis of Pyrazoles. [\[Link\]](#)
- Thieme. (2020). Regioselektive Synthese von 3,5-disubstituierten Pyrazolen. [\[Link\]](#)
- American Chemical Society. (2006). Improved Regioselectivity in Pyrazole Formation through the Use of Fluorinated Alcohols as Solvents: Synthesis and Biological Activity of Fluorinated Tebufenpyrad Analogs. *Journal of Organic Chemistry*, 71(13), 4989-4992. [\[Link\]](#)
- J&K Scientific LLC. (2025). Knorr Pyrazole Synthesis. [\[Link\]](#)
- American Chemical Society. (2022). Highly Selective N-Alkylation of Pyrazoles: Crystal Structure Evidence for Attractive Interactions. *The Journal of Organic Chemistry*, 87(15), 10036–10046. [\[Link\]](#)
- Royal Society of Chemistry. (2019). Ce-catalyzed regioselective synthesis of pyrazoles from 1,2-diols via tandem oxidation and C–C/C–N bond formation. *Organic & Biomolecular Chemistry*, 17(3), 560-564. [\[Link\]](#)
- American Chemical Society. (2020). Efficient One-Pot, Two-Component Modular Synthesis of 3,5-Disubstituted Pyrazoles. *ACS Omega*, 5(31), 19835–19842. [\[Link\]](#)
- Name-Reaction.com. (n.d.). Knorr Pyrazole Synthesis. [\[Link\]](#)
- American Chemical Society. (2006). Base-Mediated Reaction of Hydrazones and Nitroolefins with a Reversed Regioselectivity: A Novel Synthesis of 1,3,4-Trisubstituted Pyrazoles. *Organic Letters*, 8(17), 3705–3708. [\[Link\]](#)
- ResearchGate. (2025). Decoding Ortho Regiospecificity and High Endo Stereoselectivity in Pyrazole Synthesis via the Activation/Strain Model. [\[Link\]](#)
- PubMed. (2012). Cu(I)-catalyzed regioselective synthesis of pyrazolo[5,1-c]-1,2,4-triazoles. [\[Link\]](#)
- PMC. (2019). Revisiting the Structure and Chemistry of 3(5)-Substituted Pyrazoles. [\[Link\]](#)

- ResearchGate. (2006). Improved Regioselectivity in Pyrazole Formation through the Use of Fluorinated Alcohols as Solvents: Synthesis and Biological Activity of Fluorinated Tebufenpyrad Analogs. [\[Link\]](#)
- ResearchGate. (2014). Highly Regioselective Synthesis of 1-Aryl-3,4,5-Substituted Pyrazoles. [\[Link\]](#)
- Royal Society of Chemistry. (2025). Decoding ortho regiospecificity and high endo stereoselectivity in pyrazole synthesis via the activation/strain model. [\[Link\]](#)
- Organic Chemistry Portal. (n.d.). Pyrazole synthesis. [\[Link\]](#)
- American Chemical Society. (2023). Regioselective Pyrazole Synthesis via Base-Mediated [3+2] Cycloaddition of 2-Alkynyl-1,3-Dithianes and Sydnone. The Journal of Organic Chemistry, 88(5), 2993–3003. [\[Link\]](#)
- American Chemical Society. (2001). Regioselective Synthesis of Polysubstituted Pyrazoles and Isoxazoles. The Journal of Organic Chemistry, 66(22), 7422–7427. [\[Link\]](#)
- PMC. (2021). Multicomponent syntheses of pyrazoles via (3 + 2)-cyclocondensation and (3 + 2)-cycloaddition key steps. [\[Link\]](#)
- Slideshare. (2022). Knorr Pyrazole Synthesis (M. Pharm). [\[Link\]](#)
- Beilstein Journals. (2021). Multicomponent syntheses of pyrazoles via (3 + 2)-cyclocondensation and (3 + 2)-cycloaddition key steps. [\[Link\]](#)
- ResearchGate. (2021). Efficient Synthesis and Comprehensive Characterization of bis-Pyrazole Derivatives: Including X-Ray Crystallography and Hirshfeld Surface Analysis. [\[Link\]](#)
- American Chemical Society. (2026). Solvent- and Electrolyte-Dependent Highly Selective Electrochemical Transfer Hydrogenation of Pyrazolo[1,5-a]pyrimidines. The Journal of Organic Chemistry. [\[Link\]](#)
- PMC. (2022). Regioselective Synthesis, Structural Characterization, and Antiproliferative Activity of Novel Tetra-Substituted Phenylaminopyrazole Derivatives. [\[Link\]](#)

- Canadian Journal of Chemistry. (2025). The reaction between hydrazines and  $\beta$ -dicarbonyl compounds: Proposal for a mechanism. [[Link](#)]
- MDPI. (2023). Completion of Crystallographic Data for the Series of 4-Halogenated-1H-pyrazoles: Crystal Structure Determination of 4-Iodo-1H-pyrazole and Spectroscopic Comparison. [[Link](#)]

### Need Custom Synthesis?

BenchChem offers custom synthesis for rare earth carbides and specific isotopic labeling.

Email: [info@benchchem.com](mailto:info@benchchem.com) or [Request Quote Online](#).

## Sources

1. [mdpi.com](https://www.mdpi.com) [[mdpi.com](https://www.mdpi.com)]
2. [hilarispublisher.com](https://www.hilarispublisher.com) [[hilarispublisher.com](https://www.hilarispublisher.com)]
3. Discovery of unexpectedly complex reaction pathways for the Knorr pyrazole synthesis via transient flow - Reaction Chemistry & Engineering (RSC Publishing) DOI:10.1039/D2RE00271J [[pubs.rsc.org](https://pubs.rsc.org)]
4. [pdf.benchchem.com](https://pdf.benchchem.com) [[pdf.benchchem.com](https://pdf.benchchem.com)]
5. [pdf.benchchem.com](https://pdf.benchchem.com) [[pdf.benchchem.com](https://pdf.benchchem.com)]
6. [ri.conicet.gov.ar](https://ri.conicet.gov.ar) [[ri.conicet.gov.ar](https://ri.conicet.gov.ar)]
7. [researchgate.net](https://www.researchgate.net) [[researchgate.net](https://www.researchgate.net)]
8. Regioselective Synthesis, NMR, and Crystallographic Analysis of N1-Substituted Pyrazoles - PubMed [[pubmed.ncbi.nlm.nih.gov](https://pubmed.ncbi.nlm.nih.gov)]
9. [pubs.acs.org](https://pubs.acs.org) [[pubs.acs.org](https://pubs.acs.org)]
10. [researchgate.net](https://www.researchgate.net) [[researchgate.net](https://www.researchgate.net)]
11. [mdpi.com](https://www.mdpi.com) [[mdpi.com](https://www.mdpi.com)]
12. Regioselective Synthesis of 3,5-Disubstituted Pyrazoles - Thieme Chemistry - Georg Thieme Verlag KG [[thieme.de](https://www.thieme.de)]
13. Synthesis of 1,3,5-trisubstituted pyrazoles via 1,3-dipolar cycloaddition of nitrile imines with ninhydrin-derived Morita–Baylis–Hillman carbonates - Organic & Biomolecular Chemistry (RSC Publishing) [[pubs.rsc.org](https://pubs.rsc.org)]

- 14. Multicomponent syntheses of pyrazoles via (3 + 2)-cyclocondensation and (3 + 2)-cycloaddition key steps - PMC [[pmc.ncbi.nlm.nih.gov](https://pubmed.ncbi.nlm.nih.gov)]
- 15. BJOC - Multicomponent syntheses of pyrazoles via (3 + 2)-cyclocondensation and (3 + 2)-cycloaddition key steps [[beilstein-journals.org](https://beilstein-journals.org)]
- 16. Regioselective Synthesis of 1,3,5-Trisubstituted Pyrazoles from N-Alkylated Tosylhydrazones and Terminal Alkynes [[organic-chemistry.org](https://organic-chemistry.org)]
- 17. [pubs.acs.org](https://pubs.acs.org) [[pubs.acs.org](https://pubs.acs.org)]
- To cite this document: BenchChem. [Technical Support Center: Navigating Regioselectivity in Pyrazole Ring Formation]. BenchChem, [2026]. [Online PDF]. Available at: [<https://www.benchchem.com/product/b2749467/docs#technical-support-center-navigating-regioselectivity-in-pyrazole-ring-formation>]

---

### Disclaimer & Data Validity:

The information provided in this document is for Research Use Only (RUO) and is strictly not intended for diagnostic or therapeutic procedures. While BenchChem strives to provide accurate protocols, we make no warranties, express or implied, regarding the fitness of this product for every specific experimental setup.

**Technical Support:** The protocols provided are for reference purposes. Unsure if this reagent suits your experiment?

**Need Industrial/Bulk Grade?** [Request Custom Synthesis Quote](#)

## BenchChem

Our mission is to be the trusted global source of essential and advanced chemicals, empowering scientists and researchers to drive progress in science and industry.

### Contact

Address: 3281 E Guasti Rd  
Ontario, CA 91761, United States  
Phone: (601) 213-4426  
Email: [info@benchchem.com](mailto:info@benchchem.com)

Contact our Ph.D. Support Team for a compatibility check