

# Technical Support Center: Morpholine Ring Stabilization Guide

**Author:** BenchChem Technical Support Team. **Date:** May 2026

## Compound of Interest

Compound Name: 4-[2-nitro-4-(1H-pyrazol-5-yl)phenyl]morpholine

CAS No.: 1033847-04-9

Cat. No.: B2749467

[Get Quote](#)

## Introduction: The Morpholine Paradox

As researchers, we value the morpholine ring for its ability to modulate lipophilicity and solubility in drug design. However, its structural advantage—the presence of both an ether oxygen and a secondary (or tertiary) amine—creates a dual susceptibility to oxidation.

You are likely facing one of two distinct failure modes:

- N-Oxidation (Reversible/Manageable): Attack on the nitrogen lone pair by electrophilic oxidants (e.g., mCPBA,  $\text{mCPBA}$ ), forming N-oxides.
- -C-H Oxidation (Destructive/Irreversible): Abstraction of hydrogen from the carbon adjacent to the heteroatoms (by  $\text{mCPBA}$ , Ozone, or CYP450 enzymes), leading to lactams (morpholin-3-one) or ring cleavage.

This guide provides self-validating protocols to navigate these pitfalls.

## Module 1: Synthetic Troubleshooting (The Lab Bench)

### Issue 1: "I'm generating N-oxides instead of oxidizing my target alkene."

Scenario: You are using mCPBA or peracids to epoxidize an olefin elsewhere in the molecule, but the morpholine nitrogen is reacting faster.

Root Cause: The nitrogen lone pair is more nucleophilic than the alkene

-system. The Fix: The Acidic Block Strategy (Protonation)[1]

By protonating the nitrogen, you remove the lone pair from the reaction equation. The resulting ammonium salt is electrophilically inert to peracids.

Q: How do I execute this without ruining the workup? A: Follow this self-validating protocol:

#### Protocol A: Selective Oxidation via In-Situ Salt Formation

Valid for: mCPBA, Trifluoroacetic acid, Peroxides.

- Dissolution: Dissolve your morpholine substrate in DCM.
- Protection (The "Acid Block"): Add 1.1 equivalents of Trifluoroacetic Acid (TFA) or Methanesulfonic acid.
  - Validation: Check pH on wet paper; it must be <3. The amine is now an ammonium salt ( ).
- Oxidation: Add your oxidant (e.g., mCPBA) at 0°C.
  - Why: The ammonium nitrogen repels the electrophilic oxygen of the peracid.
- Quench & Deprotection:
  - Quench with saturated

(to kill excess peroxide).

- Critical Step: Basify the aqueous layer with saturated

or NaOH to pH >10. This deprotonates the ammonium salt, returning your free morpholine base.

- Extraction: Extract the free base into organic solvent.

“

*Technical Insight: Using mineral acids like HCl can sometimes introduce chloride ions that may participate in side reactions if strong oxidants are present. TFA is generally safer for organic solubility.*

## Issue 2: "Ruthenium Tetroxide ( ) is destroying my ring."

Scenario: You are performing a Sharpless oxidation or oxidative cleavage, and the morpholine ring is converting to a lactam or breaking open.

Root Cause:

is a "hydride seeker." It attacks the

-C-H bonds (adjacent to N) to form an iminium ion, which hydrolyzes to a lactam or cleaves.

The Fix: Electron Withdrawal (The "Electronic Shield")

Protonation is often insufficient for

because the reagent functions in acidic media and attacks the carbon, not just the nitrogen lone pair. You must reduce the electron density of the

-carbons.

Q: Will a Boc group save it? A: Usually, yes. An electron-withdrawing group (EWG) like Boc, Cbz, or Tosyl pulls electron density away from the

-carbons, making them less susceptible to hydride abstraction.

Protocol B:

## Survival Guide

- Pre-Reaction Check: Ensure the morpholine nitrogen is protected with a strong EWG (Tosyl > Boc > Acetyl). N-Alkyl morpholines are highly unstable to .
- Solvent System: Use a biphasic system ( or ).
  - Why: MeCN coordinates to the Ruthenium species, modulating its reactivity and preventing over-oxidation.
- Reaction Time: Keep reaction times short. Even protected amines can eventually oxidize to imides under prolonged exposure.

## Module 2: Metabolic Stability (Drug Design)

### Issue 3: "My morpholine drug candidate has high clearance."

Scenario: DMPK data shows rapid metabolism. Root Cause: Cytochrome P450 (specifically CYP3A4 and CYP2D6) oxidizes the ring at the C2 or C3 positions (alpha to O or N).

The Fix: Deuteration & Fluorination Q: Where should I modify the ring? A:

- Deuteration: Replace hydrogens at the metabolic "hotspots" (C2/C3) with Deuterium.
  - Mechanism:<sup>[2]</sup><sup>[3]</sup><sup>[4]</sup><sup>[5]</sup><sup>[6]</sup><sup>[7]</sup><sup>[8]</sup><sup>[9]</sup> The C-D bond is stronger than the C-H bond (Kinetic Isotope Effect), significantly slowing the rate-determining step of hydrogen abstraction by CYP450.

- Fluorination: Adding fluorine adjacent to the nitrogen lowers the pKa and reduces the propensity for oxidation, though this changes the electronic character of the drug significantly.

#### Data Summary: Impact of Modification on Stability

Modification	Target Site	Effect on Oxidation	Trade-off
None (Parent)	C2, C3	High Clearance	Baseline
Deuteration ( )	C2, C3	Significant Reduction (KIE ~2-5x)	High cost of goods
N-Oxide (Metabolite)	N	Phase I Metabolite	Often inactive/excreted
Gem-Dimethyl	C3	Steric Blockade	Increases lipophilicity ( )

## Visualizing the Pathways

The following diagram illustrates the divergence between N-oxidation (reversible) and C-oxidation (destructive), and the intervention points.

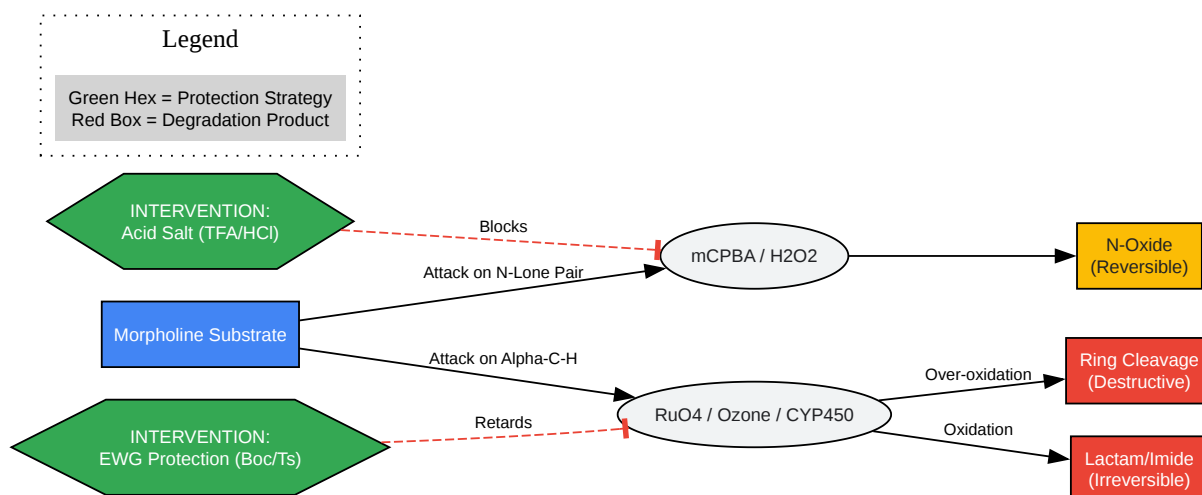

[Click to download full resolution via product page](#)

Caption: Figure 1. Divergent oxidation pathways of the morpholine ring. N-oxidation is driven by lone-pair nucleophilicity, while C-oxidation (Lactam/Cleavage) is driven by alpha-hydrogen abstraction.

## FAQs: Rapid Fire Troubleshooting

Q: Can I use

with a morpholine ring? A: Generally, yes, if the pH is controlled. Permanganate is less aggressive toward the C-H bonds of amines than

, especially in alkaline media. However, ensure no acidic conditions are present, as this accelerates oxidation.

Q: I found "Morpholin-2-one" in my LCMS. What happened? A: This indicates oxidation adjacent to the oxygen atom. This is less common synthetically but common metabolically. If observed synthetically, check for radical initiators or singlet oxygen presence in your solvent system (e.g., old ethers).

Q: How do I store morpholine derivatives long-term? A: Morpholine ethers can form peroxides over time, similar to THF.

- Protocol: Store under Argon/Nitrogen.
- Additive: Add 0.05% BHT (Butylated hydroxytoluene) as a radical scavenger if the compound is an oil and not a crystalline solid.

## References

- Mechanisms of Amine Oxidation
  - Title: Ruthenium tetroxide oxid
  - Source:Revue Roumaine de Chimie, 2016.[10]
  - URL:[[Link](#)]
- Metabolic Stability & CYP450
  - Title: Thiomorpholine and morpholine oxidation by a cytochrome P450 in Mycobacterium aurum MO1.[3]
  - Source:Biodegrad
  - URL:[[Link](#)]
- N-Oxide Prevention Strategies
  - Title: Preventing N-oxide Form
  - Source: BenchChem Technical Support.[1]
- General Oxidation Protocols
  - Title: 3-Chloroperoxybenzoic acid (mCPBA) Reactivity & Handling.
  - Source: Organic Chemistry Portal.
  - URL:[[Link](#)]

### Need Custom Synthesis?

BenchChem offers custom synthesis for rare earth carbides and specific isotopic labeling.

Email: [info@benchchem.com](mailto:info@benchchem.com) or [Request Quote Online](#).

## Sources

- [1. benchchem.com \[benchchem.com\]](https://www.benchchem.com)
- [2. Quantum chemical studies for oxidation of morpholine by Cytochrome P450 - PubMed \[pubmed.ncbi.nlm.nih.gov\]](https://pubmed.ncbi.nlm.nih.gov)
- [3. Thiomorpholine and morpholine oxidation by a cytochrome P450 in Mycobacterium aurum MO1. Evidence of the intermediates by in situ 1H NMR - PubMed \[pubmed.ncbi.nlm.nih.gov\]](https://pubmed.ncbi.nlm.nih.gov)
- [4. boa.unimib.it \[boa.unimib.it\]](https://boa.unimib.it)
- [5. researchgate.net \[researchgate.net\]](https://www.researchgate.net)
- [6. researchgate.net \[researchgate.net\]](https://www.researchgate.net)
- [7. A Mild and Sustainable Procedure for the Functionalization of Morpholin-2-Ones by Oxidative Imidation Reactions \[mdpi.com\]](https://www.mdpi.com)
- [8. Ruthenium Tetroxide \(RuO<sub>4</sub>\) | Chem-Station Int. Ed. \[en.chem-station.com\]](https://www.en.chem-station.com)
- [9. Morpholine Radical in the Electrochemical Reaction with Quinoline N-Oxide | MDPI \[mdpi.com\]](https://www.mdpi.com)
- [10. RuO<sub>4</sub>-Mediated oxidation of secondary amines. 1. Are hydroxylamines main intermediates? | Journal of the Serbian Chemical Society \[shd-pub.org.rs\]](https://shd-pub.org.rs)
- To cite this document: BenchChem. [Technical Support Center: Morpholine Ring Stabilization Guide]. BenchChem, [2026]. [Online PDF]. Available at: [\[https://www.benchchem.com/product/b2749467/docs#technical-support-center-morpholine-ring-stabilization-guide\]](https://www.benchchem.com/product/b2749467/docs#technical-support-center-morpholine-ring-stabilization-guide)

---

### Disclaimer & Data Validity:

The information provided in this document is for Research Use Only (RUO) and is strictly not intended for diagnostic or therapeutic procedures. While BenchChem strives to provide accurate protocols, we make no warranties, express or implied, regarding the fitness of this product for every specific experimental setup.

**Technical Support:** The protocols provided are for reference purposes. Unsure if this reagent suits your experiment?

**Need Industrial/Bulk Grade?** [Request Custom Synthesis Quote](#)

## BenchChem

Our mission is to be the trusted global source of essential and advanced chemicals, empowering scientists and researchers to drive progress in science and industry.

### Contact

Address: 3281 E Guasti Rd  
Ontario, CA 91761, United States  
Phone: (601) 213-4426  
Email: [info@benchchem.com](mailto:info@benchchem.com)

[Contact our Ph.D. Support Team for a compatibility check](#)