

Technical Support Center: H-D-Lys(Fmoc)-OH Synthesis

Author: BenchChem Technical Support Team. **Date:** April 2026

Compound of Interest

Compound Name: H-D-Lys(Fmoc)-OH

CAS No.: 212140-39-1

Cat. No.: B2749272

[Get Quote](#)

Welcome to the Technical Support Center for advanced peptide synthesis applications. This guide is designed for researchers, scientists, and drug development professionals who are engaged in the synthesis of **H-D-Lys(Fmoc)-OH** and may be encountering unexpected byproducts. Our goal is to provide you with in-depth troubleshooting strategies and a comprehensive set of frequently asked questions to ensure the integrity and success of your synthesis. We will delve into the causality behind common synthetic pitfalls and offer field-proven, self-validating protocols to overcome them.

Troubleshooting Guide: Unexpected Byproducts

This section addresses specific issues that can arise during the synthesis of **H-D-Lys(Fmoc)-OH**, providing diagnostic approaches and corrective actions.

Question 1: My final product shows a significant peak with a mass of +222.2 Da compared to the expected product mass. What is this impurity and how can I avoid it?

Answer:

This mass difference strongly indicates the presence of $N\alpha,N\epsilon$ -bis(Fmoc)-D-lysine. This is the most common byproduct in this synthesis, arising from the Fmoc-protecting agent reacting with both the ϵ -amino group and the α -amino group of the D-lysine starting material.

Causality: The α -amino group of D-lysine, while generally less nucleophilic than the ϵ -amino group under basic conditions, can still react with the Fmoc-donating reagent (e.g., Fmoc-OSu or Fmoc-Cl), especially if the reaction conditions are not carefully controlled. Direct reaction of D-lysine with Fmoc-OSu or Fmoc-Cl is known to have poor selectivity, often leading to significant amounts of this di-substituted byproduct[1].

Diagnostic Protocol: HPLC-MS and NMR Analysis

- HPLC-MS: Perform a reverse-phase HPLC analysis coupled with mass spectrometry. The di-Fmoc byproduct will have a significantly longer retention time than the desired mono-Fmoc product due to its increased hydrophobicity. The expected mass of $N\alpha,N\epsilon$ -bis(Fmoc)-D-lysine is approximately 590.6 g/mol, which corresponds to the mass of **H-D-Lys(Fmoc)-OH** (368.4 g/mol) plus the mass of an additional Fmoc group (222.2 g/mol).
- ^1H NMR: In the ^1H NMR spectrum of the mixture, the di-Fmoc byproduct will exhibit a more complex set of aromatic protons corresponding to the two fluorenyl groups.

Preventative Measures & Protocols:

The key to preventing the formation of $N\alpha,N\epsilon$ -bis(Fmoc)-D-lysine is to enhance the selectivity of the Fmoc protection towards the ϵ -amino group. This is typically achieved by transiently protecting the α -amino group.

Protocol 1: Copper(II) Complexation Method

This is a widely used and effective method for selective ϵ -amino group protection of lysine[2][3]. The copper ion forms a chelate with the α -amino and carboxyl groups, sterically hindering the α -amino group from reacting with the Fmoc-reagent.

- Copper Complex Formation:

- Dissolve D-lysine hydrochloride in water.
- Add basic copper(II) carbonate and reflux the mixture. The solution will turn a deep blue color, indicating the formation of the copper complex.
- Filter the hot solution and lyophilize the filtrate to obtain the copper-complexed D-lysine.
- ϵ -Fmocylation:
 - Suspend the copper-complexed D-lysine in a suitable solvent mixture (e.g., dioxane/water or acetone/water).
 - Add a base such as sodium bicarbonate or sodium carbonate to maintain a basic pH (around 9-10).
 - Slowly add a solution of Fmoc-OSu (9-fluorenylmethyloxycarbonyl-N-hydroxysuccinimide) in dioxane or acetone to the lysine solution while stirring vigorously at room temperature.
 - Monitor the reaction progress by TLC or HPLC.
- Decomplexation:
 - Once the reaction is complete, decompose the copper complex by adding a solution of EDTA (ethylenediaminetetraacetic acid) or by passing the solution through a Chelex resin.
 - Acidify the solution to precipitate the **H-D-Lys(Fmoc)-OH** product.
 - Filter, wash with cold water, and dry the product.

Protocol 2: Imine Intermediate Method

This method involves the transient protection of the α -amino group as a Schiff base (imine)[1].

- Imine Formation: React D-lysine hydrochloride with an aromatic aldehyde (e.g., benzaldehyde) in the presence of a base to form an imine at the α -amino group.
- ϵ -Fmocylation: React the imine intermediate with an Fmoc-protecting reagent.

- Hydrolysis: Hydrolyze the imine under acidic conditions to regenerate the free α -amino group, yielding **H-D-Lys(Fmoc)-OH**.

Question 2: I observe a byproduct with a mass that is 18.01 Da less than my starting D-lysine, and it appears to have reacted with the Fmoc-reagent. What is this species?

Answer:

A mass loss of 18.01 Da from the starting material suggests an intramolecular dehydration reaction, leading to the formation of a lactam. In the case of lysine, this would be a piperidone derivative. This lactam can then react with the Fmoc-reagent, leading to an Fmoc-protected lactam byproduct.

Causality: Under certain conditions, particularly at elevated temperatures, the ϵ -amino group of lysine can attack the carboxyl group, leading to the formation of a cyclic amide (lactam) and the elimination of a water molecule[4].

Diagnostic Protocol: FTIR and Mass Spectrometry

- Mass Spectrometry: The Fmoc-protected lactam will have a mass corresponding to the mass of the Fmoc group plus the mass of the lysine lactam.
- FTIR Spectroscopy: The presence of a lactam ring can be identified by a characteristic C=O stretching frequency in the range of 1650-1680 cm^{-1} , which may be distinguishable from the amide C=O of the Fmoc group.

Preventative Measures:

- Temperature Control: Avoid excessive heating during the reaction and workup steps. The Fmocylation reaction should ideally be carried out at or below room temperature.
- pH Control: Maintain the pH of the reaction mixture in the recommended range for Fmoc protection (typically pH 9-10). Extreme pH values can promote side reactions.

Frequently Asked Questions (FAQs)

Q1: What is the fundamental principle of selective N ϵ -protection of lysine?

The selective protection of the ϵ -amino group of lysine relies on the principle of orthogonal protection[5]. This strategy involves the use of protecting groups that can be removed under different conditions, allowing for the selective deprotection of one functional group while others remain protected. For the synthesis of **H-D-Lys(Fmoc)-OH**, the goal is to introduce the base-labile Fmoc group onto the ϵ -amino group while leaving the α -amino group free for subsequent peptide coupling. This is typically achieved by transiently protecting the α -amino group, as described in the troubleshooting guide.

Q2: Can I use H-L-Lys(Fmoc)-OH and **H-D-Lys(Fmoc)-OH** interchangeably in my peptide synthesis?

No, these are stereoisomers and are not interchangeable. The use of the D-enantiomer (**H-D-Lys(Fmoc)-OH**) is a specific strategic choice in peptide design, often to increase the peptide's resistance to enzymatic degradation by proteases, which typically recognize L-amino acids[6]. The incorporation of a D-amino acid can significantly alter the peptide's conformation and biological activity.

Q3: How can I confirm the purity of my synthesized **H-D-Lys(Fmoc)-OH**?

A multi-technique approach is recommended for comprehensive purity assessment:

- High-Performance Liquid Chromatography (HPLC): This is the standard method for assessing chemical purity. A reversed-phase C18 column with a water/acetonitrile gradient containing 0.1% TFA is commonly used.
- Mass Spectrometry (MS): To confirm the molecular weight of the product and identify any byproducts.
- Nuclear Magnetic Resonance (NMR) Spectroscopy: ^1H and ^{13}C NMR are used to confirm the chemical structure and identify any structural isomers or impurities.
- Chiral HPLC or Polarimetry: To confirm the enantiomeric purity and ensure that no racemization has occurred during the synthesis.

Q4: What are the optimal storage conditions for **H-D-Lys(Fmoc)-OH**?

H-D-Lys(Fmoc)-OH should be stored in a cool, dry, and dark place, preferably at 2-8°C, to prevent degradation[7]. The Fmoc group is sensitive to basic conditions, so it should be protected from exposure to alkaline environments.

Data Summary

Byproduct/Impurity	Molecular Weight (g/mol)	Mass Difference from Product (Da)	Common Cause	Recommended Analytical Technique
N α ,N ϵ -bis(Fmoc)-D-lysine	590.6	+222.2	Non-selective Fmoc protection	HPLC-MS, ¹ H NMR
Fmoc-D-lysine lactam	~350.4	-18.01 (relative to Fmoc-D-lysine)	Intramolecular cyclization at elevated temperatures	MS, FTIR
Unreacted D-lysine	146.2	-222.2	Incomplete reaction	HPLC with ninhydrin staining, TLC
H-L-Lys(Fmoc)-OH	368.4	0 (isomeric)	Use of L-lysine starting material	Chiral HPLC, Polarimetry

Visualizing Reaction Pathways and Troubleshooting

Diagram 1: Synthesis of **H-D-Lys(Fmoc)-OH** via Copper Complexation

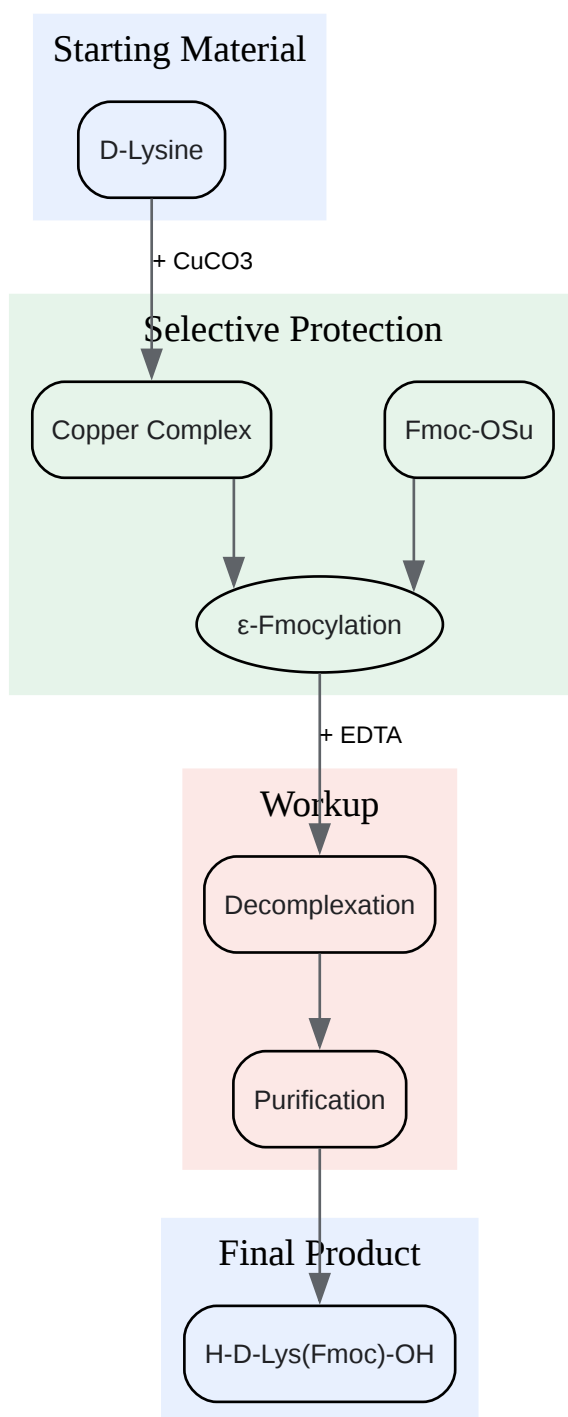

[Click to download full resolution via product page](#)

Caption: Workflow for selective N ϵ -Fmoc protection of D-lysine.

Diagram 2: Troubleshooting Unexpected Byproducts

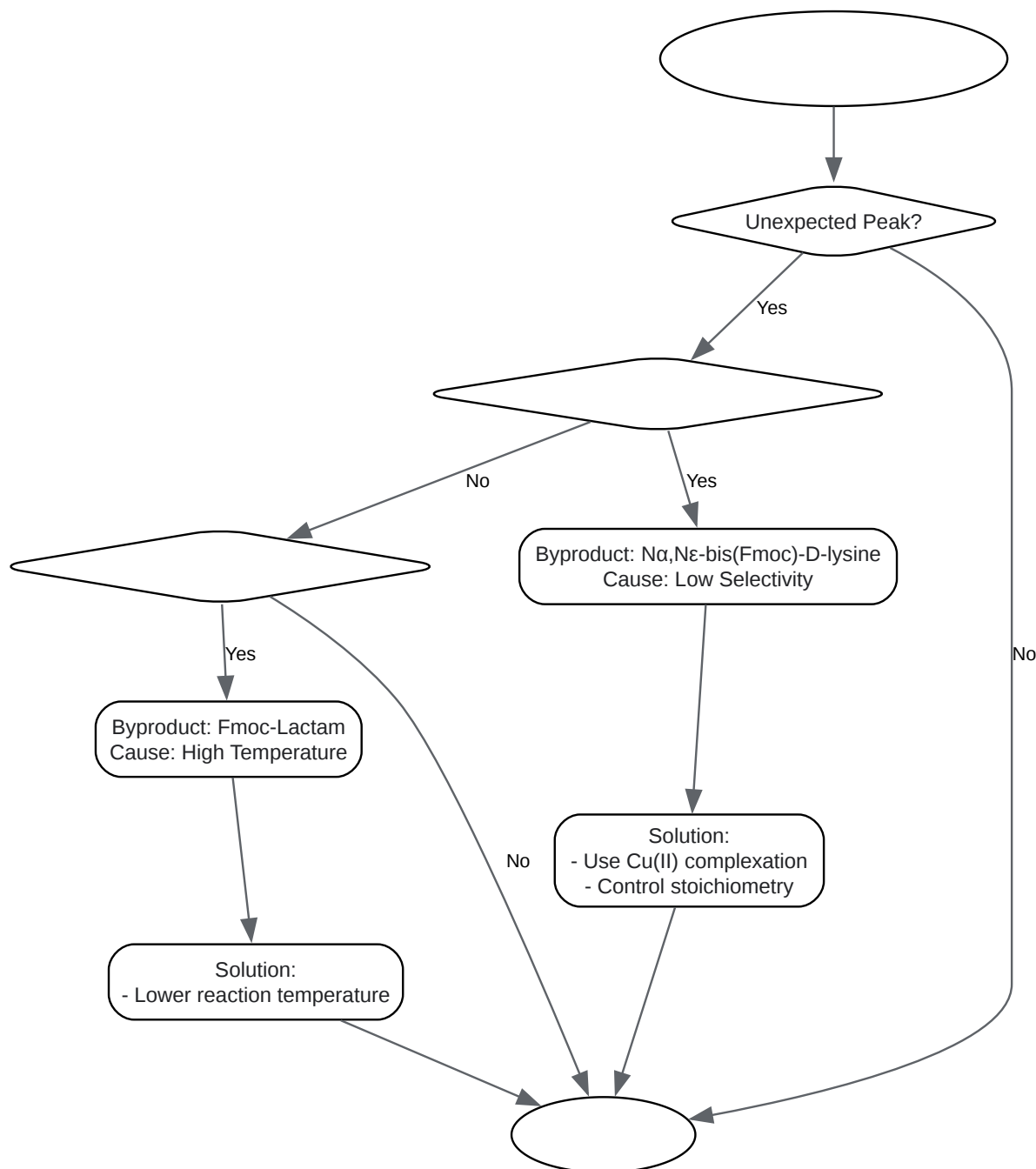

[Click to download full resolution via product page](#)

Caption: Decision tree for identifying and resolving common byproducts.

References

- Ningbo Inno Pharmchem Co., Ltd. (2026, January 1). The Importance of Lysine Protection: A Deep Dive into Fmoc-Lys(Mmt)-OH.
- Sigma-Aldrich. Selecting Orthogonal Building Blocks.
- BenchChem. (2025).
- Open Access Pub. (2024, September 19). Protection Side Chain of Lysine by Host-Affinity Molecules during Solid Phase Peptide Synthesis in Aqueous Phase.
- CymitQuimica. CAS 146982-27-6: N(alpha)-fmoc-N(epsilon)-alloc-L-lysine.
- ACS Publications. (2024, January 5).
- BenchChem. (2025).
- ACS Omega.
- Taylor & Francis Online. (2006, August 21). Synthesis of N- α -Fmoc-N- ϵ -Tetrabutyl Ester-EDTA-L-lysine: An Amino Acid Analog to Prepare Affinity Cleaving Peptides.
- Organic Letters. (2002).
- Journal of the Chemical Society of Pakistan. (1998).
- PubMed. (2012, December 21). Effective regioselective protection of amino groups of lysine achieved by a supramolecular enzyme-mimic approach.
- ResearchGate.
- Ningbo Inno Pharmchem Co., Ltd.
- Google Patents. (2023).
- ResearchGate. (2006, August 21). Synthesis of N- α -Fmoc-N- ϵ -Tetrabutyl Ester-EDTA-L-lysine: An Amino Acid Analog to Prepare Affinity Cleaving Peptides.
- PubMed. (2007, July 15). Concise preparation of N(alpha)-Fmoc-N(epsilon)-(Boc, methyl)
- ChemicalBook. (2022, December 12). FMOC-LYS(BOC)(ME)
- PMC. Solid-phase synthesis of d-fructose-derived Heyns peptides utilizing N α -Fmoc-Lysin[N ϵ -(2-deoxy-d-glucos-2-yl),N ϵ -Boc]-OH as building block.
- PubMed. (2002, December 15). Fmoc-N(epsilon)-tetra-t-butyl-DTPA-L-lysine, building blocks for solid phase synthesis of DTPA-containing peptides.
- PMC. The Synthesis and Application of Fmoc-Lys(5-Fam) Building Blocks.
- Sigma-Aldrich. Fmoc-Lys(Dde)-OH Novabiochem 150629-67-7.
- BenchChem. (2025). Application of Fmoc-D-Lys(Fmoc)-OH in the Synthesis of Complex Peptides.
- ChemPep. Fmoc Solid Phase Peptide Synthesis.
- Florida International University. (2023, April 25).
- Peptides Intern
- Peptides Intern
- Royal Society of Chemistry. Organic & Biomolecular Chemistry.
- MedChemExpress. H-Lys(Fmoc)-OH.
- Google Patents. (2020).

- Merck Millipore.
- Sigma-Aldrich. Fmoc-Lys(Mmt)-OH Novabiochem 159857-60-0.
- Semantic Scholar. (2008, December 5).

Need Custom Synthesis?

BenchChem offers custom synthesis for rare earth carbides and specific isotopic labeling.

Email: info@benchchem.com or [Request Quote Online](#).

Sources

- [1. CN119118875A - Preparation method of Fmoc-L-lysine - Google Patents \[patents.google.com\]](#)
- [2. cpb.pharm.or.jp \[cpb.pharm.or.jp\]](#)
- [3. The Synthesis and Application of Fmoc-Lys\(5-Fam\) Building Blocks - PMC \[pmc.ncbi.nlm.nih.gov\]](#)
- [4. researchgate.net \[researchgate.net\]](#)
- [5. pdf.benchchem.com \[pdf.benchchem.com\]](#)
- [6. pdf.benchchem.com \[pdf.benchchem.com\]](#)
- [7. medchemexpress.com \[medchemexpress.com\]](#)
- To cite this document: BenchChem. [Technical Support Center: H-D-Lys(Fmoc)-OH Synthesis]. BenchChem, [2026]. [Online PDF]. Available at: [\[https://www.benchchem.com/product/b2749272/docs#technical-support-center-h-d-lys-fmoc-oh-synthesis\]](https://www.benchchem.com/product/b2749272/docs#technical-support-center-h-d-lys-fmoc-oh-synthesis)

Disclaimer & Data Validity:

The information provided in this document is for Research Use Only (RUO) and is strictly not intended for diagnostic or therapeutic procedures. While BenchChem strives to provide accurate protocols, we make no warranties, express or implied, regarding the fitness of this product for every specific experimental setup.

Technical Support: The protocols provided are for reference purposes. Unsure if this reagent suits your experiment?

Need Industrial/Bulk Grade? [Request Custom Synthesis Quote](#)

BenchChem

Our mission is to be the trusted global source of essential and advanced chemicals, empowering scientists and researchers to drive progress in science and industry.

Contact

Address: 3281 E Guasti Rd
Ontario, CA 91761, United States
Phone: (601) 213-4426
Email: info@benchchem.com

[Contact our Ph.D. Support Team for a compatibility check](#)