

# Introduction: The Critical Role of Chirality in Modern Drug Discovery

**Author:** BenchChem Technical Support Team. **Date:** May 2026

## Compound of Interest

Compound Name: *5-Bromo-2-(butan-2-yl)-4-chloropyrimidine*

CAS No.: *1506786-09-9*

Cat. No.: *B2749808*

[Get Quote](#)

In the realm of medicinal chemistry, the three-dimensional arrangement of atoms in a molecule, or its stereochemistry, is a paramount determinant of its biological activity.[1][2] Many drugs are chiral, meaning they exist as non-superimposable mirror images called enantiomers.[3] These enantiomers, while possessing identical chemical formulas and connectivity, can exhibit profoundly different pharmacological and toxicological profiles.[4][5][6] This disparity arises from the chiral nature of biological targets such as enzymes and receptors, which often interact preferentially with one enantiomer over the other.[2][4]

The U.S. Food and Drug Administration (FDA) has established guidelines that underscore the importance of understanding the stereochemistry of chiral drugs early in the development process.[4] These regulations necessitate the characterization of individual enantiomers and an understanding of their distinct effects. Consequently, the ability to identify, separate, and analyze chiral centers within a drug candidate is a fundamental requirement for the development of safe and effective therapeutics.[2][4] This guide provides a comprehensive technical overview of the chiral center present in **5-Bromo-2-(butan-2-yl)-4-chloropyrimidine**, a substituted pyrimidine with potential applications in drug discovery. Pyrimidine derivatives are

of significant interest in medicinal chemistry due to their diverse biological activities, including anticancer and antimicrobial properties.[7]

## Molecular Structure and Identification of the Chiral Center

The chemical structure of **5-Bromo-2-(butan-2-yl)-4-chloropyrimidine** is key to understanding its stereochemical properties. A chiral center, or stereocenter, is typically a carbon atom bonded to four different substituent groups.[3][8]

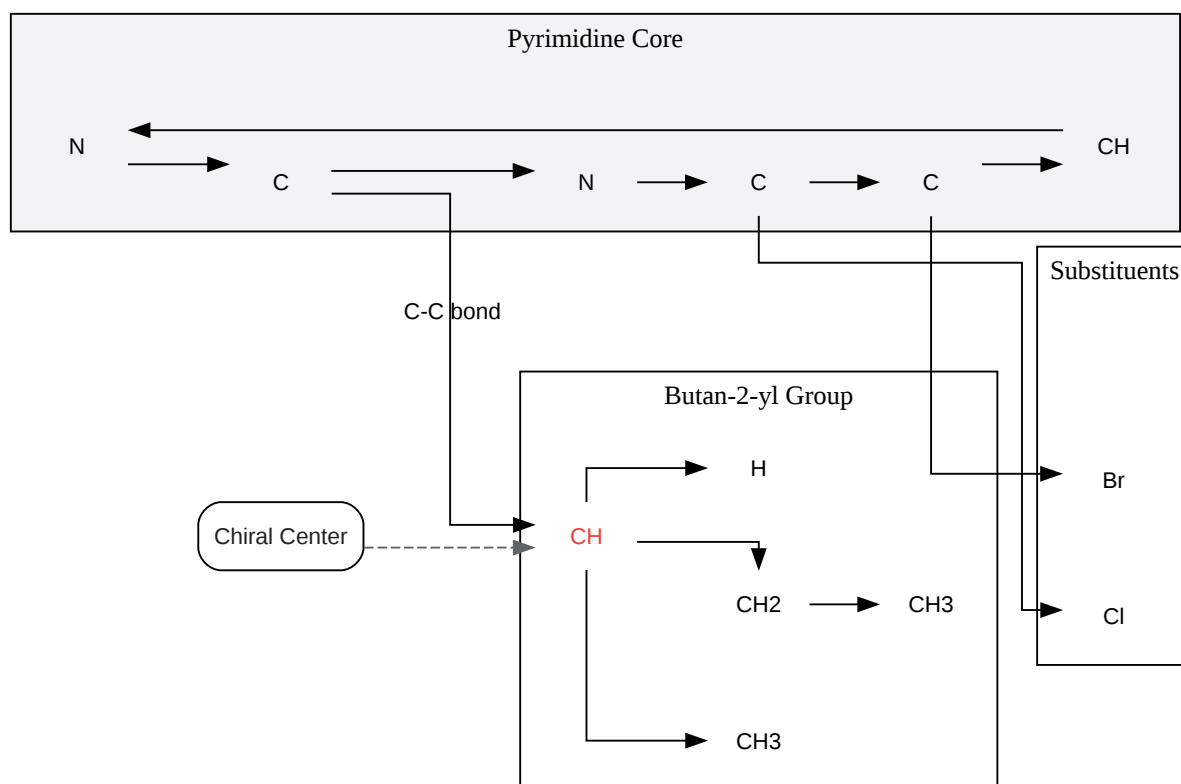

[Click to download full resolution via product page](#)

Caption: Molecular structure of **5-Bromo-2-(butan-2-yl)-4-chloropyrimidine** with the chiral center highlighted.

In **5-Bromo-2-(butan-2-yl)-4-chloropyrimidine**, the chiral center is located within the butan-2-yl substituent. Specifically, it is the second carbon atom of the butyl chain (C2 of the butyl group). This carbon is bonded to four distinct groups:

- A hydrogen atom (H)
- A methyl group (-CH<sub>3</sub>)
- An ethyl group (-CH<sub>2</sub>CH<sub>3</sub>)
- The pyrimidine ring system

Due to this arrangement, **5-Bromo-2-(butan-2-yl)-4-chloropyrimidine** can exist as a pair of enantiomers, designated as (R)-**5-Bromo-2-(butan-2-yl)-4-chloropyrimidine** and (S)-**5-Bromo-2-(butan-2-yl)-4-chloropyrimidine**.

## Implications of Chirality for Biological Activity

The presence of a chiral center in **5-Bromo-2-(butan-2-yl)-4-chloropyrimidine** has significant implications for its potential as a therapeutic agent. The two enantiomers, (R) and (S), will interact differently with chiral biological macromolecules.<sup>[4][5]</sup> This can lead to stereoselectivity in various aspects of its pharmacological profile:

- **Pharmacodynamics:** One enantiomer (the eutomer) may exhibit significantly higher binding affinity and efficacy at the target receptor or enzyme, while the other (the distomer) may be less active or even inactive.<sup>[4]</sup>
- **Pharmacokinetics:** Differences in absorption, distribution, metabolism, and excretion (ADME) between enantiomers can occur.
- **Toxicology:** In some cases, the distomer may be responsible for undesirable side effects or toxicity.<sup>[5][6]</sup>

Therefore, it is crucial to synthesize and evaluate the biological activity of each enantiomer separately to identify the eutomer and develop a stereochemically pure drug substance.

# Analytical Techniques for Chiral Separation and Characterization

The separation and characterization of the enantiomers of **5-Bromo-2-(butan-2-yl)-4-chloropyrimidine** are essential for preclinical and clinical development. Several analytical techniques are available for this purpose, with chiral High-Performance Liquid Chromatography (HPLC) being the most common and reliable method.

## Experimental Protocol: Chiral HPLC for Enantiomeric Separation

This protocol outlines a general procedure for the separation of the (R) and (S) enantiomers of **5-Bromo-2-(butan-2-yl)-4-chloropyrimidine**.

Objective: To resolve and quantify the enantiomeric purity of a sample of **5-Bromo-2-(butan-2-yl)-4-chloropyrimidine**.

Materials:

- **5-Bromo-2-(butan-2-yl)-4-chloropyrimidine** sample (racemic mixture or enantiomerically enriched)
- HPLC-grade hexane
- HPLC-grade isopropanol
- Chiral stationary phase (CSP) HPLC column (e.g., a polysaccharide-based column such as Chiralcel OD-H or Chiralpak AD-H)
- HPLC system with a UV detector

Methodology:

- **Mobile Phase Preparation:** Prepare an isocratic mobile phase consisting of a mixture of hexane and isopropanol. A typical starting ratio is 90:10 (v/v). The optimal ratio may need to be determined empirically.

- Sample Preparation: Dissolve a known concentration of the **5-Bromo-2-(butan-2-yl)-4-chloropyrimidine** sample in the mobile phase to a final concentration of approximately 1 mg/mL.
- HPLC System Setup:
  - Install the chiral HPLC column in the column compartment.
  - Equilibrate the column with the mobile phase at a constant flow rate (e.g., 1.0 mL/min) until a stable baseline is achieved.
  - Set the UV detector to a wavelength where the compound exhibits strong absorbance (this can be determined by UV-Vis spectroscopy).
- Injection and Data Acquisition:
  - Inject a small volume (e.g., 10  $\mu$ L) of the prepared sample onto the column.
  - Acquire the chromatogram for a sufficient duration to allow for the elution of both enantiomers.
- Data Analysis:
  - Identify the two peaks corresponding to the (R) and (S) enantiomers.
  - Calculate the resolution between the two peaks to ensure adequate separation.
  - Determine the enantiomeric excess (% ee) of the sample by calculating the area of each peak.



[Click to download full resolution via product page](#)

Caption: Experimental workflow for chiral HPLC analysis.

## Data Presentation

The results of the chiral HPLC analysis can be summarized in a table for clarity.

Parameter	Value
Column	Chiralcel OD-H (or similar)
Mobile Phase	90:10 Hexane:Isopropanol
Flow Rate	1.0 mL/min
Detection Wavelength	To be determined
Retention Time (Enantiomer 1)	tR1
Retention Time (Enantiomer 2)	tR2
Resolution (Rs)	> 1.5 (for baseline separation)
Enantiomeric Excess (% ee)	Calculated from peak areas

## Conclusion

The presence of a single chiral center in the butan-2-yl substituent of **5-Bromo-2-(butan-2-yl)-4-chloropyrimidine** dictates that it exists as a pair of enantiomers. A thorough understanding and characterization of these stereoisomers are imperative for any drug development program involving this compound. The distinct pharmacological and toxicological properties of each enantiomer must be investigated to ensure the development of a safe and effective therapeutic agent. Chiral HPLC provides a robust and reliable method for the separation and quantification of these enantiomers, enabling the determination of enantiomeric purity and supporting the advancement of a single-enantiomer drug candidate.

## References

- MDPI. Synthesis of Chiral Acyclic Pyrimidine Nucleoside Analogues from DHAP-Dependent Aldolases. Available at: [\[Link\]](#)
- PubMed. Chiral pyrrolo[2,3-d]pyrimidine and pyrimido[4,5-b]indole derivatives: structure-activity relationships of potent, highly stereoselective A1-adenosine receptor antagonists.

Available at: [\[Link\]](#)

- PMC. The Significance of Chirality in Drug Design and Development. Available at: [\[Link\]](#)
- Juniper Publishers. Role of Chirality in Drugs. Available at: [\[Link\]](#)
- RSC Publishing. The significance of chirality in contemporary drug discovery-a mini review. Available at: [\[Link\]](#)
- MDPI. A Look at the Importance of Chirality in Drug Activity: Some Significant Examples. Available at: [\[Link\]](#)
- Computational Chemistry | Blog. Chirality Perspective in Drug Design and Development. Available at: [\[Link\]](#)
- Khan Academy. Chiral carbon & chiral drugs | Stereochemistry (article). Available at: [\[Link\]](#)
- YouTube. Chiral Centers - Organic Chemistry Notes 5.1. Available at: [\[Link\]](#)
- PubMed. Structure-Activity Relationships of Pyrimidine Derivatives and their Biological Activity - A Review. Available at: [\[Link\]](#)
- Khan Academy. Chiral examples 2 (video). Available at: [\[Link\]](#)
- MSU chemistry. Stereoisomers. Available at: [\[Link\]](#)
- Chiral molecules. Chiral molecules. Available at: [\[Link\]](#)

#### ***Need Custom Synthesis?***

*BenchChem offers custom synthesis for rare earth carbides and specific isotopic labeling.*

*Email: [info@benchchem.com](mailto:info@benchchem.com) or [Request Quote Online](#).*

## Sources

- [1. The significance of chirality in contemporary drug discovery-a mini review - RSC Advances \(RSC Publishing\) DOI:10.1039/D4RA05694A \[pubs.rsc.org\]](#)

- [2. mdpi.com \[mdpi.com\]](https://www.mdpi.com)
- [3. Khan Academy \[khanacademy.org\]](https://www.khanacademy.org)
- [4. The Significance of Chirality in Drug Design and Development - PMC \[pmc.ncbi.nlm.nih.gov\]](https://pubmed.ncbi.nlm.nih.gov/31111111/)
- [5. juniperpublishers.com \[juniperpublishers.com\]](https://www.juniperpublishers.com)
- [6. lifechemicals.com \[lifechemicals.com\]](https://www.lifechemicals.com)
- [7. Structure-Activity Relationships of Pyrimidine Derivatives and their Biological Activity - A Review - PubMed \[pubmed.ncbi.nlm.nih.gov\]](https://pubmed.ncbi.nlm.nih.gov/31111111/)
- [8. m.youtube.com \[m.youtube.com\]](https://www.youtube.com)
- To cite this document: BenchChem. [Introduction: The Critical Role of Chirality in Modern Drug Discovery]. BenchChem, [2026]. [Online PDF]. Available at: [\[https://www.benchchem.com/product/b2749808/docs#introduction-the-critical-role-of-chirality-in-modern-drug-discovery\]](https://www.benchchem.com/product/b2749808/docs#introduction-the-critical-role-of-chirality-in-modern-drug-discovery)

---

**Disclaimer & Data Validity:**

The information provided in this document is for Research Use Only (RUO) and is strictly not intended for diagnostic or therapeutic procedures. While BenchChem strives to provide accurate protocols, we make no warranties, express or implied, regarding the fitness of this product for every specific experimental setup.

**Technical Support:** The protocols provided are for reference purposes. Unsure if this reagent suits your experiment?

**Need Industrial/Bulk Grade?** [Request Custom Synthesis Quote](#)

## BenchChem

Our mission is to be the trusted global source of essential and advanced chemicals, empowering scientists and researchers to drive progress in science and industry.

### Contact

Address: 3281 E Guasti Rd  
Ontario, CA 91761, United States  
Phone: (601) 213-4426  
Email: [info@benchchem.com](mailto:info@benchchem.com)

Contact our Ph.D. Support Team for a compatibility check